

---



HP 5973  
Mass Selective Detector

# Hardware Manual

---

All Rights Reserved.  
Reproduction, adaptation, or  
translation without prior  
written permission is  
prohibited, except as allowed  
under the copyright laws.

## Document History

Publication number  
G1099-90027

First edition, 11/98  
Printed in USA

## Warranty

The information contained in  
this document is subject to  
change without notice.

Hewlett-Packard makes no  
warranty of any kind with  
regard to this material,  
including, but not limited to,  
the implied warranties of  
merchantability and fitness for  
a particular purpose.

Hewlett-Packard shall not be  
liable for errors contained  
herein or for incidental or  
consequential damages in  
connection with the furnishing,  
performance or use of this  
material.

Hewlett-Packard assumes no  
responsibility for the use or  
reliability of its software on  
equipment that is not  
furnished by Hewlett-Packard.

## Instrument Identification

Each HP 5973 Mass Selective  
Detector (MSD) is identified  
by a unique 10-character serial  
number. This serial number is  
located on a label on the lower  
left side near the front of the  
instrument. On CI upgrades, a  
serial number is located on the  
flow module.

When corresponding with  
Hewlett-Packard about your  
instrument, be sure to include  
the model number and both  
full 10-character serial  
numbers.

Write the serial number of your  
HP 5973 MSD here for  
reference:

MSD serial #:

\_\_\_\_\_

## HP 5973 MSD version

HP 5973 MSDs are equipped  
with either a diffusion pump or  
a turbomolecular (turbo)  
pump. Chemical Ionization is  
available for the turbo MSD  
only. The serial number label  
displays a product number that  
tells what kind of MSD you  
have:

G1098A = Diffusion pump  
G1099A = Turbo pump  
G1999A = CI (turbo pump)

## Noise Declaration

### Deutsch

LpA << 70 dB am Arbeitsplatz  
normaler Betrieb nach EN  
27779:1991

### English

LpA << 70 dB operator  
position normal operation per  
ISO 7779:1988

## Manual Conventions

### Cautions

Cautions call attention to  
procedures which, if not  
correctly performed or  
adhered to, could result in  
**damage to the instrument.**

### Warnings

Warnings call attention to  
procedures which, if not  
correctly performed or  
adhered to, could result in  
**personal injury.**

### Part Numbers

In this manual, Hewlett-  
Packard part numbers are  
generally listed in parentheses  
after the name of the part or in  
tables in the *Parts* chapter.  
Most Hewlett-Packard part  
numbers are either four-digit-  
by-four-digit (1234-1234)  
numbers or five-digit-by-five-  
digit (12345-12345) numbers.

A few tools and supplies listed  
have no part numbers and are  
not available from Hewlett-  
Packard. Most of these can be  
obtained from laboratory  
supply companies.

## Safety Information

### Safety Symbols (on equipment)



Refer to operating  
instructions



Indicates hazardous  
voltage



Indicates hot surface



Indicates earth  
(ground) terminal

## Safety class

The HP 5973 Mass Selective  
Detector (MSD) is a Safety  
Class I instrument and has  
been designed and tested in  
accordance with IEC  
Publication 1010-1 Safety  
Requirements for Electrical  
Equipment for Measurement,  
Control, and Laboratory Use.

### WARNING

Connecting an MSD to a power  
source which is not equipped  
with a protective earth contact  
creates a shock hazard for the  
operator and can damage the  
instrument. Likewise,  
interrupting the protective  
conductor inside or outside the  
MSD or disconnecting the  
protective earth terminal  
creates a shock hazard for the  
operator and can damage the  
instrument.

### WARNING

Make sure that only fuses with  
the required current rating and  
of the specified type are used  
for replacement. The use of  
incorrect or makeshift fuses or  
the short-circuiting of fuse  
holders creates a shock hazard  
for the operator and can  
damage the instrument.

### WARNING

Any adjustment, maintenance  
or repair of the opened  
instrument while it is  
connected to a power source  
should be avoided if possible  
and, if required, should be  
carried out only by trained  
persons who are aware of the  
hazards involved.

*Safety Information* is contin-  
ued on the inside of the back  
cover.

---

HP 5973  
Mass Selective Detector

---

Hardware Manual

---

# The HP 5973 Mass Selective Detector

## ***The HP 5973 MSD is a stand-alone capillary GC detector***

The HP 5973 Mass Selective Detector (MSD) is designed for use with the HP 6890 Series Gas Chromatograph. The MSD features:

- Either a 90 L/sec vapor-diffusion or a 250 L/sec turbomolecular high vacuum pump
- Rotary vane foreline pump
- Independently heated electron-ionization ion source
- Independently heated hyperbolic quadrupole mass filter
- High-energy dynode (HED) electron multiplier detector
- Independently heated GC/MSD interface
- Power supplies and instrument control electronics

## ***Operator control of the MSD is through the data system***

The data system features Hewlett-Packard MSD ChemStation software. It includes programs to calibrate (tune) the MSD, acquire data, and analyze data.

***Tuning*** programs adjust voltages in the ion source, calibrate mass assignments, and control the scanning of the analyzer.

***Data acquisition*** programs allow you to monitor the total ion chromatogram (TIC), automatically storing the mass spectra of GC peaks as they elute. This is the scan mode. Alternatively, you can monitor the concentrations of particular ions. This is selected ion monitoring mode (SIM).

***Data analysis*** programs allow you to integrate chromatograms (TIC or SIM), view and manipulate mass spectral data, compare spectra to databases of reference spectra in a library search, quantitate data, and generate reports.

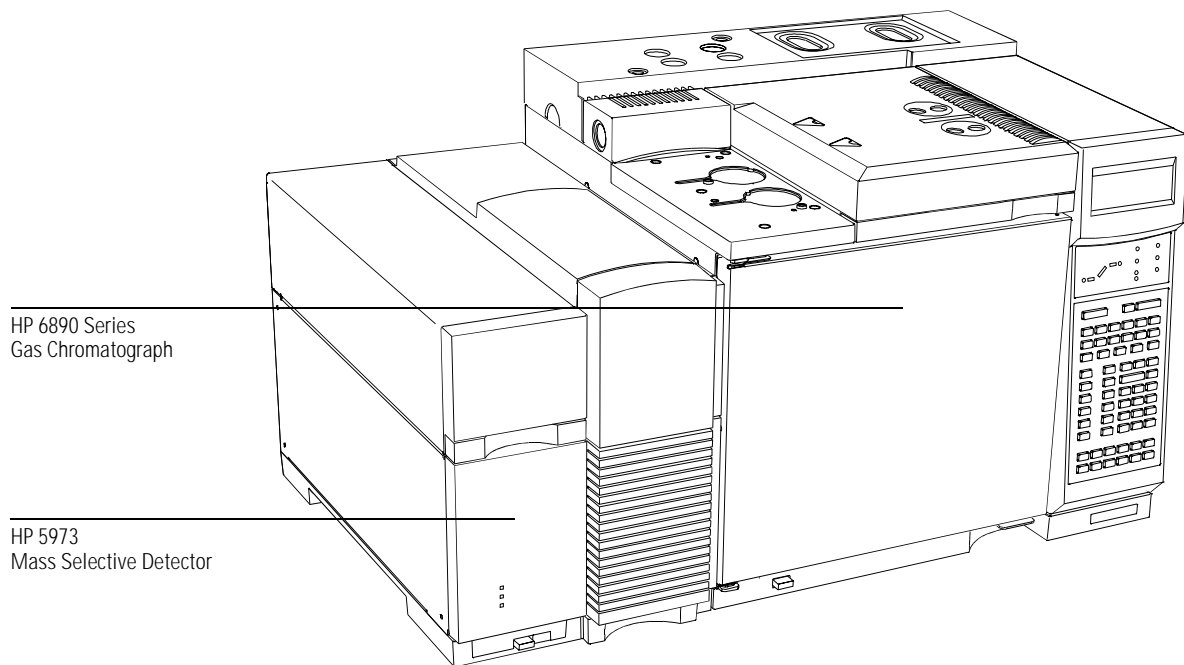

***An optional gauge controller is available for measuring vacuum***

The HP 5973 MSD is equipped with a triode gauge tube. With an HP 59864B Gauge Controller, the tube can be used to measure pressure (high vacuum) in the vacuum manifold. Installation and operation of the gauge controller is described in this manual.

The gauge controller is ***required*** for chemical ionization (CI) operation.

---

# In This Manual

This manual describes the operation, troubleshooting, and maintenance of the HP 5973 Mass Selective Detector. Chapters 1 – 4 describe common operation, troubleshooting, and maintenance tasks. Chapters 5 – 8 contain reference material about the major systems of the MSD. Chapter 9 is a parts reference.

- Chapter 1 shows you how to prepare and install a capillary column.
- Chapter 2 describes basic tasks such as setting temperatures, monitoring pressures, tuning, and venting, and pumpdown.
- Chapter 3 provides a quick reference for identifying causes of poor instrument performance or malfunctions.
- Chapter 4 features maintenance procedures.
- Chapter 5 describes operation of the components of the vacuum system.
- Chapter 6 describes the GC/MSD interface.
- Chapter 7 describes operation of the ion source, mass filter, and detector.
- Chapter 8 describes the electronics that control the MSD.
- Chapter 9 contains illustrated parts identification and part numbers.

To report errors in this manual, please send e-mail to [chem@sid.hp.com](mailto:chem@sid.hp.com). For updated information, check the HP Chemical Analysis web site at <http://chem.external.hp.com/cag/main.html>.

## ***HP 5973 Mass Selective Detector Reference Collection***

The two CD-ROM set includes the following multimedia resources:

- Hardware maintenance procedures for the HP 5973 MSD and HP 6890 Series GC
- Software tutorial: hands-on training
- Mass Spectrometer Fundamentals: *Mass spectrometer hardware*, and *Acquiring and evaluating (mass) spectra*

---

# Table of Contents

## Chapter 1

### Installing GC Columns

- To prepare a capillary column for installation, 20
- To install a capillary column in a split/splitless inlet, 22
- To condition a capillary column, 24
- To install a capillary column without the installation tool, 26
- To install a capillary column using the installation tool, 28

## Chapter 2

### Operating the MSD

- To view MSD analyzer temperature and vacuum status, 36
- To set monitors for MSD temperature and vacuum status, 38
- To set the MSD analyzer temperatures, 40
- To set the interface temperature from the ChemStation, 42
- To monitor high vacuum pressure, 44
- To measure column flow linear velocity, 46
- To calculate column flow, 47
- To tune the MSD, 48
- To set the interface temperature from an HP 6890 GC, 49
- To remove the MSD covers, 50
  - Upper MSD cover, 50
  - Lower MSD cover, 50
- To vent the MSD, 52
- To open the vacuum manifold, 54
- To close the vacuum manifold, 56
- To pump down the MSD, 58
- To connect the optional gauge controller, 60
- To move or store the MSD, 62
- To vent the MSD without the ChemStation, 64

**Chapter 3****Troubleshooting the MSD**

- General symptoms, 68
    - GC does not turn on, 68
    - MSD does not turn on, 68
    - Foreline pump is not operating, 68
    - Fan for the high vacuum pump is not operating, 69
    - MSD is on but the status LEDs are all blinking, 69
    - MSD turns on but then the foreline pump shuts off, 69
  - Chromatographic symptoms, 70
    - No peaks, 70
      - Passes tune, 70
      - Does not pass tune, 71
    - Peaks are tailing, 71
    - Peaks are fronting, 71
    - Peaks have flat tops, 72
    - Peaks have split tops, 72
    - Baseline is rising, 72
    - Baseline is high, 72
    - Baseline is falling, 72
    - Baseline wanders, 73
    - Retention times for all peaks drift – shorter, 73
    - Retention times for all peaks drift – longer, 73
    - Poor sensitivity, 74
    - Poor Repeatability, 74
  - Mass spectral symptoms, 75
    - Isotopes are missing or isotope ratios are incorrect, 75
    - High background, 75
    - High abundances at  $m/z$  18, 28, 32, and 44 or at  $m/z$  14 and 16, 75
    - Mass assignments are incorrect, 76
    - Peaks have precursors, 76
    - Peak widths are inconsistent, 76
    - Relative abundance of  $m/z$  502 is less than 3%, 77
    - Spectra look different from those acquired with other HP MSDs, 77
    - High mass sensitivity is poor, 78
  - Pressure symptoms, 79
    - Foreline pressure is too high, 79
    - Vacuum manifold pressure is too high, 79
    - Foreline pressure is too low, 80
    - Vacuum manifold pressure is too low, 80
    - Gauge controller displays 9.9+9 and then goes blank, 80
    - Power indicator on the gauge controller does not light, 81
-

- Temperature symptoms, 82
  - Ion source will not heat up, 82
  - Mass filter (quad) heater will not heat up, 83
  - GC/MSD interface will not heat up, 83
- Error messages, 84
  - Difficulty in mass filter electronics, 84
  - Difficulty with the electron multiplier supply, 84
  - Difficulty with the fan, 85
  - Difficulty with the HED supply, 85
  - Difficulty with the high vacuum pump, 85
    - Diffusion pump, 85
    - Turbomolecular pump, 86
  - Foreline pressure has exceeded 300 mTorr, 86
  - Internal MS communication fault, 86
  - Lens supply fault, 86
  - Log amplifier ADC error, 86
  - No peaks found, 86
  - Temperature control disabled, 87
  - Temperature control fault, 87
  - The high vacuum pump is not ready, 87
  - The system is in standby, 87
  - The system is in vent state, 88
  - There is no emission current, 88
  - There is not enough signal to begin tune, 88
- Air leaks, 89
- Contamination, 90

## Chapter 4

### Maintaining the MSD

#### Before starting 94

#### Maintaining the vacuum system 101

- To check and add foreline pump oil, 102
- To drain the foreline pump, 104
- To refill the foreline pump, 106
- To replace the oil trap, 108
- To check the diffusion pump fluid, 110
- To separate the MSD from the GC, 112
- To remove the diffusion pump, 114
- To replace the diffusion pump fluid, 116
- To reinstall the diffusion pump, 118
- To reconnect the MSD to the GC, 120
- To remove the calibration vial, 122
- To refill and reinstall the calibration vial, 124
- To remove the foreline gauge, 126
- To reinstall a foreline gauge, 128
- To remove the calibration valve, 130
- To reinstall a calibration valve, 132
- To replace the fan for the high vacuum pump, 134
- To remove the triode gauge tube, 136
- To reinstall a triode gauge tube, 138
- To lubricate the side plate O-ring, 140
- To lubricate the vent valve O-ring, 142

#### Maintaining the analyzer 144

- To remove the ion source, 146
- To disassemble the ion source, 148
- To clean the ion source, 150
- To reassemble the ion source, 154
- To reinstall the ion source, 156
- To remove a filament, 158
- To reinstall a filament, 160
- To remove the heater and sensor from the ion source, 162
- To reinstall the heater and sensor in the ion source, 164
- To remove the heater and sensor from the mass filter, 166
- To reinstall the heater and sensor in the mass filter, 168
- To replace the electron multiplier horn, 170

**Maintaining the GC/MSD interface 172**

To remove the GC/MSD interface heater and sensor, 173

To reinstall the GC/MSD interface heater and sensor, 175

**Maintaining the electronics 177**

To adjust the RF coils, 179

To replace the primary fuses, 181

**Chapter 5****Vacuum System**

Diffusion pump MSD vacuum system, 186

Turbo pump MSD vacuum system, 187

Diffusion pump vacuum manifold, 188

Turbo pump vacuum manifold, 189

Side plate, 190

Vacuum seals, 192

    Face seals, 192

    KF (NW) seals, 192

    Compression seals, 192

    High voltage feedthrough seal, 193

Foreline pump, 194

Foreline gauge, 196

Diffusion pump and fan, 198

Turbomolecular pump and fan, 202

Calibration valve and vent valve, 204

    Calibration valve, 204

    Vent valve, 204

Triode gauge tube, 206

Gauge controller, 208

**Chapter 6****GC/MSD Interface**

**Chapter 7**

**Analyzer**

- Ion source, 218
  - Ion source body, 218
  - Filaments, 219
    - Filament selection, 219
    - Emission current, 220
    - Electron energy, 220
    - Filament care, 221
  - Magnet, 221
  - Repeller, 221
  - Drawout plate and cylinder, 222
  - Ion focus, 222
  - Entrance lens, 222
    - Entrance lens offset, 222
    - Entrance lens gain, 222
- Mass filter, 223
  - AMU gain, 223
  - AMU offset, 224
  - 219 width, 224
  - DC polarity, 225
  - Mass (axis) gain, 225
  - Mass (axis) offset, 225
  - Quadrupole maintenance, 226
- Detector, 227
  - Detector focus lens, 227
  - High energy dynode, 227
  - Electron multiplier horn, 227
- Analyzer heaters and radiators, 230

## Chapter 8      **Electronics**

- Side board, 236
- Electronics module, 237
- Main board, 238
- Signal amplifier board, 239
- HP-IB/MS control card, 240
- AC board, 241
  - Pumpdown safety shutdown, 242
- Power supplies, 243
  - Low voltage (ac-dc) power supply, 243
  - High voltage (HED) power supply, 243
- Toroid transformer, 244
- Back panel and connectors, 245
  - Remote start connector, 245
  - I/O (HP-IB) connector, 245
  - HP-IB address switch, 245
  - High vacuum signal (**HIVAC SIGNAL**) connector, 246
  - High vacuum power (**HIVAC POWER**) connector, 246
  - Power cord receptacle, 246
  - Foreline pump power cord receptacle, 246
  - Primary fuses, 246
- Interfacing to external devices, 248
  - Remote control processor, 248
  - Remote start signals, 248
    - System ready, 249
    - Start run input, 249
- Status display and power switch, 250
  - Power status LED, 250
  - Analyzer status LED, 250
  - Cal valve status LED, 250
  - Power switch, 250
- Turbo pump controller, 252

**Chapter 9**

**Parts**

Electronics, 256

Vacuum system, 260

Analyzer, 268

GC/MSD interface, 274

Consumables and maintenance supplies, 276

---

# 1

- To prepare a capillary column for installation, 20
- To install a capillary column in a split/splitless inlet, 22
- To condition a capillary column, 24
- To install a capillary column without the installation tool, 26
- To install a capillary column using the installation tool, 28

---

## Installing GC Columns

How to connect GC columns to the MSD

---

## Installing GC columns

Before you can operate your GC/MSD system, you must select, condition, and install a GC column. This chapter will show you how to install and condition a column. For correct column and flow selection, you must know what type of vacuum system your MSD has. The serial number tag on the lower front of the left side panel shows the model number.

<b>Model number</b>	<b>Vacuum system</b>	<b>Software vacuum monitor</b>
HP G1098A	Diffusion pump	Foreline pressure
HP G1099A	Turbo pump	Turbo speed

### ***Many types of GC columns can be used with the MSD but there are some restrictions***

During tuning or data acquisition the rate of column flow into the MSD should not exceed 2.0 milliliters per minute for the diffusion pump MSD, or 4.0 milliliters per minute for the turbomolecular pump MSD. Therefore, there are limits to column length and flow.

- Narrow-bore columns (0.20 mm id or 0.25 mm id) can be installed directly into the GC/MSD interface. Do not exceed recommended column flow.
- Wide-bore columns (0.32 mm id), and megabore columns (0.53 mm id) at least 100 meters long, can be installed directly into the GC/MSD interface of the turbo pump MSD. Flow restrictions apply. Wide-bore and megabore columns cannot be used with the diffusion pump MSD.

This information is summarized in Table 1. The dimensions listed are nominal values. The velocities and flows listed are calculated values at 70 °C. Actual values can vary from column to column and vary greatly with oven temperature, unless the electronic pneumatic control (EPC) on the GC is set for constant flow. See *To measure column flow linear velocity* (page 46) for instructions on how to measure actual flow in your column.

Table 1

GC column information			
Column diameter (mm) <sup>1</sup>	Column length (meters) <sup>1</sup>	Head pressure (psi)	Column flow (ml/min) <sup>2</sup>
0.100	10	100	1.83
0.200	60	58.8	2.0
	30	37.3	2.0
	15	22.0	2.0
	15	30.3	4.0
0.250	60	32.3	2.0
	30	18.5	2.0
	15	8.8	2.0
	15	18.5	4.0 <sup>3</sup>
0.32 <sup>3</sup> (wide-bore)	60	25.9	4.0 <sup>3</sup>
	30	14.0	4.0 <sup>3</sup>
	15	5.6	4.0 <sup>3</sup>
0.53 <sup>3</sup> (megabore)	100	4.41	4.0 <sup>3</sup>
	75	1.85 <sup>4</sup>	4.0

1 Nominal dimensions

2 Calculated values at 70 °C with vacuum compensation turned on

3 Acceptable for turbo pump MSD only

4 Not acceptable – flow too high or head pressure too low for accurate control

***Conditioning a column before it is installed into the GC/MSD interface is essential***

A small portion of the capillary column stationary phase is often carried away by the carrier gas. This is called column bleed. Column bleed deposits traces of the stationary phase in the MSD ion source. This decreases MSD sensitivity and makes cleaning of the ion source necessary.

Column bleed is most common in new or poorly cross-linked columns. It is much worse if there are traces of oxygen in the carrier gas when the column is heated. To minimize column bleed, all capillary columns should be conditioned **before** they are installed in the GC/MSD interface.

***Conditioning ferrules is also beneficial***

Heating ferrules to their maximum expected operating temperature a few times before they are installed can reduce chemical bleed from the ferrules.

***Tips and hints***

- Note that the column installation procedure is different from that for **all** other Hewlett-Packard mass spectrometers and MSDs. Using the procedure from another instrument will not work.
- For optimal sensitivity performance, install your capillary column *without* using the installation tool.
- You can remove old ferrules from column nuts with an ordinary push pin.
- Always use carrier gas that is at least 99.999% pure.
- Because of thermal expansion, new ferrules may loosen after heating and cooling a few times. Check for tightness after two or three heating cycles.
- Always wear clean gloves when handling columns, especially the end that will be inserted into the GC/MSD interface.

---

**W A R N I N G**

---

**If you are using hydrogen as a carrier gas, do not start carrier gas flow until the column is installed in the MSD, and the MSD has been pumped down. If the vacuum pumps are off, hydrogen will accumulate in the MSD and an explosion may occur. Read the *Hydrogen Carrier Gas Safety Guide* (5955-5398) before operating the MSD with hydrogen carrier gas.**

---

**W A R N I N G**

---

**Always wear safety glasses when handling capillary columns. Use care to avoid puncturing your skin with the end of the column.**

To prepare a capillary column for installation

---

## To prepare a capillary column for installation

*Materials needed:*

Capillary column  
Column cutter (5181-8836)  
Ferrules  
    0.27-mm id, for 0.10-mm id columns (5062-3518)  
    0.37-mm id, for 0.20-mm id columns (5062-3516)  
    0.40-mm id, for 0.25-mm id columns (5181-3323)  
    0.47-mm id, for 0.32-mm id columns (5062-3514)  
    0.74-mm id, for 0.53-mm id columns (5062-3512)  
Gloves, clean  
    large (8650-0030)  
    small (8650-0029)  
Inlet column nut (5181-8830)  
Magnifying glass  
Septum (may be old, used inlet septum)

**1 Slide a septum, column nut, and conditioned ferrule onto the free end of the column.**

The tapered end of the ferrule should point away from the column nut.

**2 Use the column cutter to score the column 2 cm from the end.**

**3 Break off the end of the column.**

Hold the column against the column cutter with your thumb. Break the column against edge of the column cutter.

**4 Inspect the end for jagged edges or burrs.**

If the break is not clean and even, repeat steps 2 and 3.

**5 Wipe the outside of the free end of the column with a lint-free cloth moistened with methanol.**

To prepare a capillary column for installation

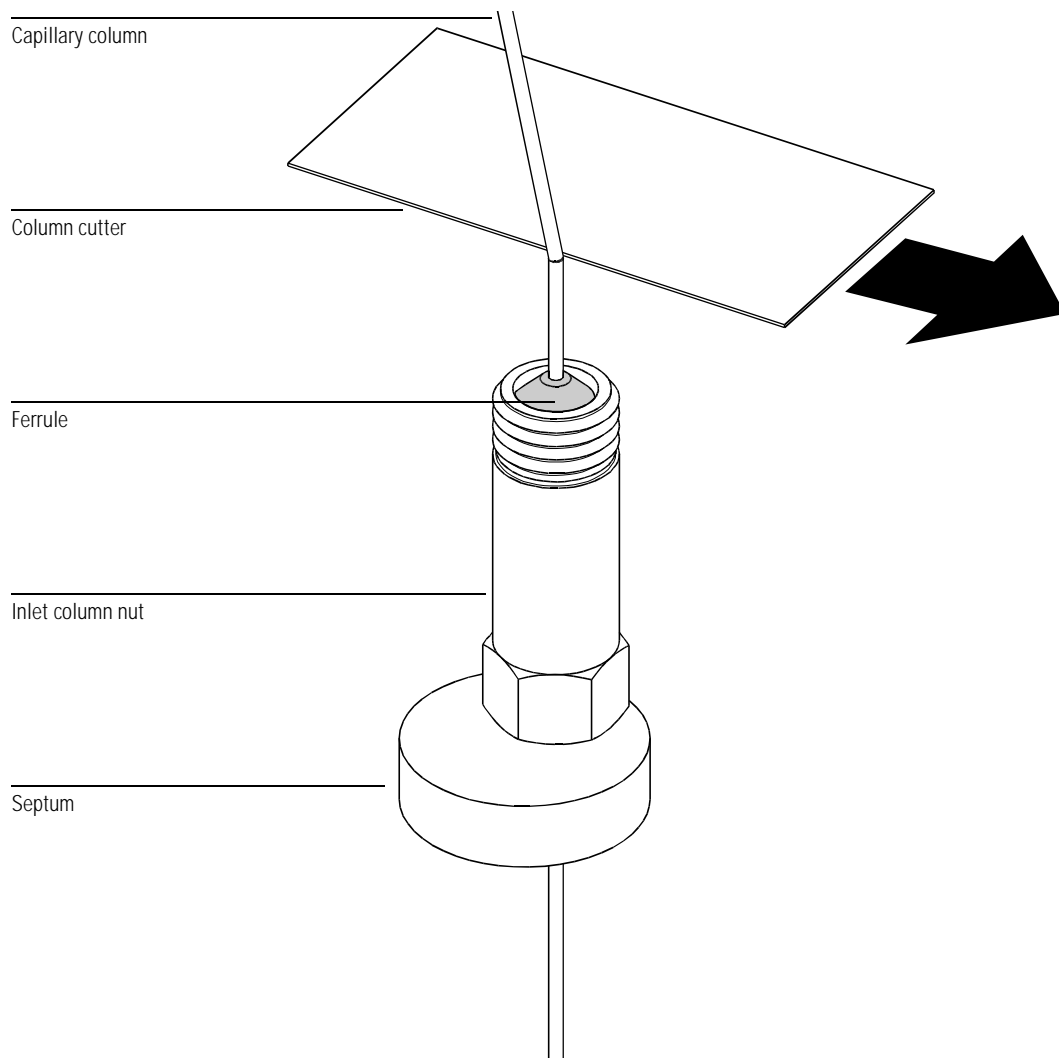

To install a capillary column in a split/splitless inlet

---

To install a capillary column in a split/splitless inlet

*Materials needed:*

Gloves, clean  
    large (8650-0030)  
    small (8650-0029)  
Metric ruler  
Wrench, open-end, 1/4-inch × 5/16-inch (8710-0510)

To install columns in other types of inlets, refer to your HP 6890 Series Gas Chromatograph Operating Manual.

- 1 Prepare the column for installation (page 20).**
- 2 Position the column so it extends 4 to 6 mm past the end of the ferrule.**
- 3 Slide the septum to place the nut and ferrule in the correct position.**
- 4 Insert the column in the inlet.**
- 5 Slide the nut up column the to the inlet base and finger tighten the nut.**
- 6 Adjust the column position so the septum is even with the bottom of the column nut.**
- 7 Tighten the column nut an additional 1/4 to 1/2 turn.**  
The column should not slide with a gentle tug.
- 8 Start carrier gas flow.**
- 9 Verify flow by submerging the column end in isopropanol. Look for bubbles.**

To install a capillary column in a split/splitless inlet

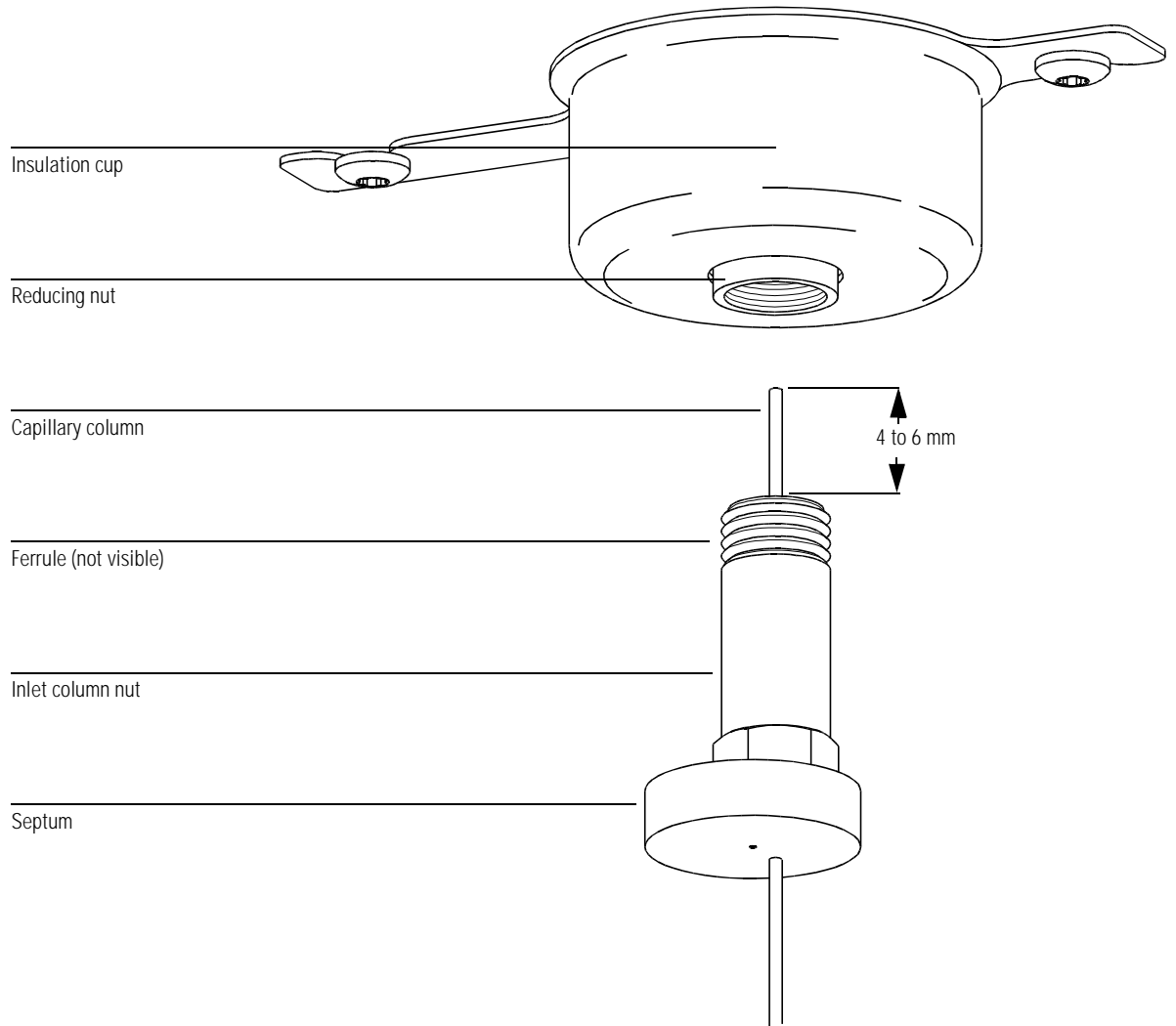

## To condition a capillary column

*Materials needed:*

Carrier gas, (99.999% pure or better)  
Wrench, open-end, 1/4-inch × 5/16-inch (8710-0510)

---

**W A R N I N G**

**Do not condition your capillary column with hydrogen. Hydrogen accumulation in the GC oven can result in an explosion. If you plan to use hydrogen as your carrier gas, first condition the column with ultrapure (99.999% or better) inert gas such as helium, nitrogen, or argon.**

- 1 Install the column in the GC inlet, page 22.**
- 2 Allow the carrier gas to flow through the column for 5 minutes without heating GC oven.**
- 3 Ramp the oven temperature at 5°C/minute to 10°C above your highest analytical temperature.**

---

**C A U T I O N**

Do not exceed the maximum temperature rating of the column.

- 4 Hold this temperature. Allow the carrier gas to flow for several hours.**
- 5 Return the GC oven temperature to a low standby temperature.**

**See Also**

For more information about installing a capillary column, refer to the Hewlett-Packard application note: *Optimizing splitless injections on your GC for high performance MS analysis*, publication number 5091-4587E.

**Oven**

On      Setpoint °C:

Actual °C:

Oven Ramp	°C/min	Next °C	Hold min	Run Time
Initial		<input type="text" value="25"/>	5.00	5.00
Ramp 1	5.00	270	300.00	354.00
Ramp 2	0.00	240	0.00	
Ramp 3	30.00	270	0.00	
Ramp 4	0.00	0	0.00	
Ramp 5	0.00	0	0.00	
Ramp 6	0.00	0	0.00	
Post Run		<input type="text" value="25"/>	20.00	

## To install a capillary column without the installation tool

*Materials needed:*

Column cutter (5181-8836)  
Ferrules  
    0.3-mm id, for 0.10-mm id columns (5062-3507)  
    0.4-mm id, for 0.20- and 0.25-mm id columns (5062-3508)  
    0.5-mm id, for 0.32-mm id columns (5062-3506)  
    0.8-mm id, for 0.53-mm id columns (5062-3538)  
Flashlight  
Gloves, clean  
    large (8650-0030)  
    small (8650-0029)  
Interface column nut (05988-20066)  
Safety glasses  
Wrench, open-end, 1/4-inch × 5/16-inch (8710-0510)

*Note:* This procedure is recommended for optimal sensitivity performance.

- 1 Condition the column (page 24).**
- 2 Vent the MSD (page 52) and open the vacuum manifold (page 54).**  
Be sure you can see the end of the GC/MSD interface.
- 3 Slide an interface nut and ferrule onto the free end of the GC column.**
- 4 Slide the column into the GC/MSD interface until you can pull it out through the vacuum manifold.**
- 5 Break 1 cm off the end of the column (page 20).**  
Do not let any column fragments fall into the vacuum manifold. They could damage the turbo pump.
- 6 Clean the outside of the free end of the column with a lint-free cloth moistened with methanol.**
- 7 Adjust the column so it projects 1 to 2 mm past the end of the GC/MSD interface.**
- 8 Hand tighten the nut.**  
Make sure the position of the column does not change as you tighten the nut.

## To install a capillary column without the installation tool

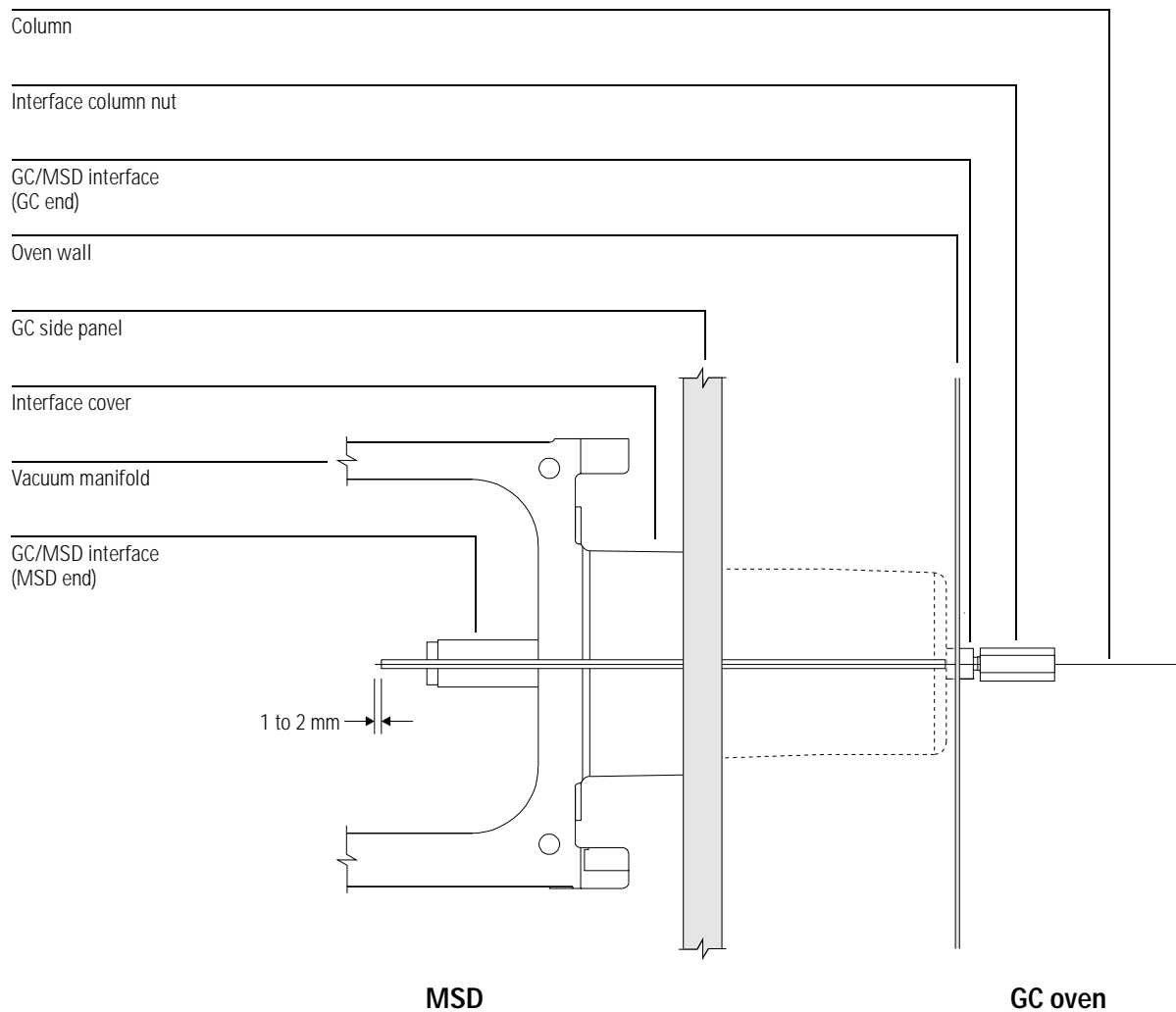
**9 Tighten the nut 1/4 to 1/2 turn.**

Check tightness after one or two heat cycles.

To install a capillary column using the installation tool

---

## To install a capillary column using the installation tool

*Materials needed:*

Column cutter (5181-8836)

Column installation tool (G1099-20030)

Ferrules

0.3-mm id, for 0.10-mm id columns (5062-3507)

0.4-mm id, for 0.20- and 0.25-mm id columns (5062-3508)

0.5-mm id, for 0.32-mm id columns (5062-3506)

0.8-mm id, for 0.53-mm id columns (5062-3538)

Gloves, clean

large (8650-0030)

small (8650-0029)

Interface column nut (05988-20066)

Septum (may be old, used inlet septum)

Wrenches, open-end, 1/4-inch × 5/16-inch (8710-0510) – 2 required

For optimal sensitivity performance, see *To install a capillary column without the installation tool*, 26.

**1 Slide a septum, interface column nut, and conditioned ferrule onto the free end of the column.**

The tapered end of the ferrule should point toward the nut.

**2 Insert the column into the column installation tool.**

Slide the column through until the end extends past the end of the tool.

**3 Cut 1 cm off the end of the column (page 20).**

**4 Position the column so that 1 to 2 mm extends past the end of the tool. Hand tighten the nut.**

**5 Slide the septum to touch the end of the nut.**

The septum will help assure that the position is correct.

**6 Use two wrenches to tighten the nut 1/4 turn.**

The column should not slide when tugged *gently*.

**7 Remove the column and nut from the installation tool.**

The total length from the septum to the end of the column is 176 mm.

## To install a capillary column using the installation tool

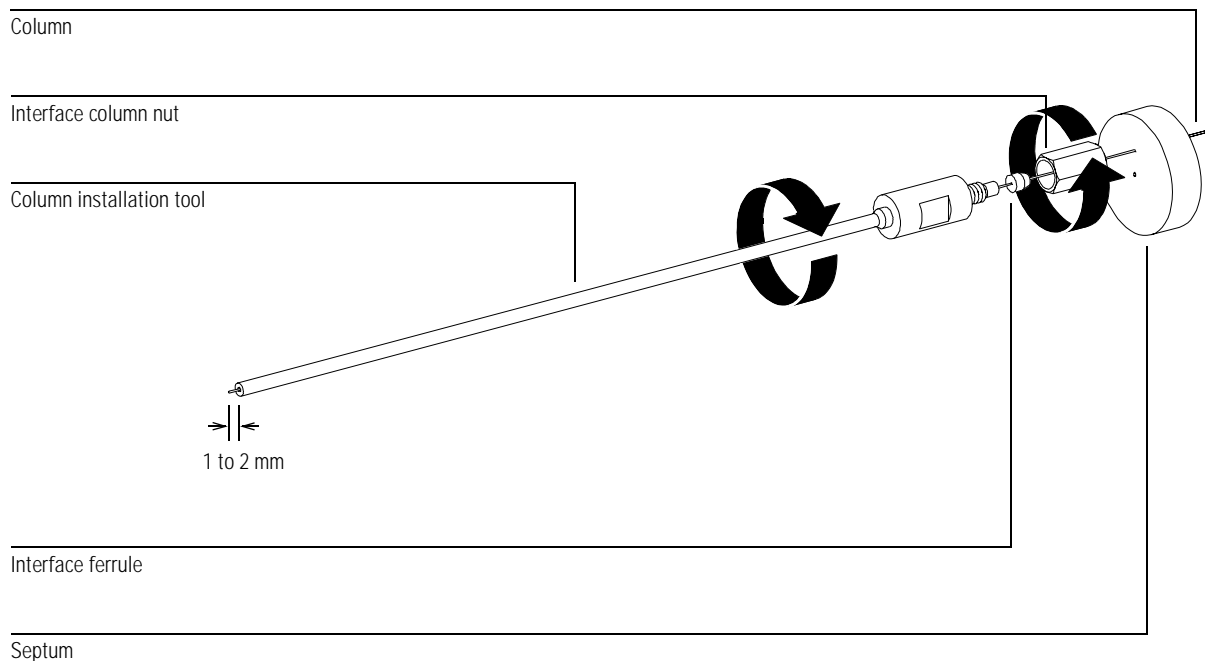

**8 Clean the outside of the end of the column with a lint-free cloth moistened with methanol.**

**9 Insert the column into the GC/MSD interface.**

**10 Tighten the nut 1/4 to 1/2 turn.**

Check tightness after one or two heat cycles.

---

**CAUTION**

---

The column installation tool must be kept *clean* to prevent contaminating the column and the ion source. Keep it in its storage tube, and clean it by flushing with methanol after each use.

---



- To view MSD analyzer temperature and vacuum status, 36
- To set monitors for MSD temperature and vacuum status, 38
- To set the MSD analyzer temperatures, 40
- To set the interface temperature from the ChemStation, 42
- To monitor high vacuum pressure, 44
- To measure column flow linear velocity, 46
- To calculate column flow, 47
- To tune the MSD, 48
- To set the interface temperature from an HP 6890 GC, 49
- To remove the MSD covers, 50
- To vent the MSD, 52
- To open the vacuum manifold, 54
- To close the vacuum manifold, 56
- To pump down the MSD, 58
- To connect the optional gauge controller, 60
- To move or store the MSD, 62
- To vent the MSD without the ChemStation, 64

---

## Operating the MSD

How to perform some basic operating procedures for the MSD

---

# Operating the MSD

## ***Operation of the MSD is primarily from the data system***

Except for the main power switch, the MSD has no switches, knobs or other physical controls. You control the MSD through a data system equipped with MSD Productivity ChemStation software. The software performs tasks such as pumpdown, monitoring pressures, setting temperatures, tuning, and preparing to vent. These tasks are described in this chapter. Data acquisition and data analysis are described in the manuals and online help supplied with the MSD ChemStation software.

## ***Some conditions must be met before you turn on the MSD***

Verify the following **before** you turn on or attempt to operate the MSD.

- The vent valve must be closed (the knob turned all the way clockwise).
- All other vacuum seals and fittings must be in place and fastened correctly. (The the front side plate screw must be secure, but not over tight).
- The MSD is connected to a grounded power source.
- The GC/MSD interface extends into the GC oven.
- A conditioned capillary column is installed in the GC inlet and in the GC/MSD interface.
- The GC is on, but the heated zones for the GC/MSD interface, the injection port, and the oven are off.
- Carrier gas of at least 99.999% purity is plumbed to the GC with the recommended traps.
- If hydrogen is used as carrier gas, carrier gas flow must be off, and the front sideplate thumbscrew must be loosely fastened.
- The foreline pump exhaust is properly vented.

---

## **W A R N I N G**

**Connecting the MSD to an ungrounded power source creates a shock hazard for the operator and can damage the instrument.**

---

---

**W A R N I N G**

**The exhaust from the foreline pump contains solvents and the chemicals you are analyzing. It also contains traces of pump oil. The supplied oil trap stops only pump oil. It does not trap or filter out toxic chemicals. If you are using toxic solvents or analyzing toxic chemicals, remove the oil trap. Install a hose to take the foreline pump exhaust outside or to a fume hood.**

---

**W A R N I N G**

**If you are using hydrogen as a carrier gas, do not start carrier gas flow until the MSD has been pumped down. If the vacuum pumps are off, hydrogen will accumulate in the MSD and an explosion may occur. Read the *Hydrogen Carrier Gas Safety Guide* (5955-5398) before operating the MSD with hydrogen carrier gas.**

---

***The data system helps you pump down the MSD***

Pumpdown is mostly automated. Once you close the vent valve and turn on the main power switch (pressing on the sideplate), the MSD pumps down by itself. The data system software contains a program that monitors and displays system status during pumpdown. When the pressure is low enough, the program turns on the ion source and mass filter heaters. It also prompts you to turn on the GC/MSD interface heater. Newer MSDs will shutdown if they cannot pump down correctly.

***Pressure in the MSD can be monitored two ways***

The diffusion pump MSD is equipped with a gauge that measures foreline pressure. Foreline pressure can be monitored only through the data system. The turbo pump MSD does not have a foreline gauge. Instead, the data system displays turbo pump motor speed.

Each MSD is equipped with a triode gauge tube. If your MSD is also equipped with an HP 59864B Gauge Controller, the triode gauge can measure the pressure in the vacuum manifold. The high vacuum pressure measured by the triode gauge cannot be monitored through the data system. It is displayed on the gauge controller.

***MSD temperatures are controlled through the data system***

The MSD has independent heaters and temperature sensors for the ion source and quadrupole mass filter. You can adjust the setpoints and view these temperatures from the data system.

The GC/MSD interface heater is powered and controlled by the Thermal Aux #2 heated zone of the HP 6890 Series GC. The GC/MSD interface temperature can be set and monitored from the data system or from the GC keypad.

***Column flow is controlled through the data system***

Carrier gas flow through the GC column is controlled by head pressure in the GC. For a given head pressure, the column flow will decrease as the GC oven temperature increases. With electronic pneumatic control (EPC) set to **Const Flow** (constant flow), the same column flow is maintained regardless of oven temperature.

The MSD can be used to measure actual column flow. You inject a **small** amount of air or other unretained chemical, and time how long it takes to reach the MSD. With this time, you can calculate the column flow.

***The data system aids in venting***

A program in the data system guides you through the venting process. It switches off the GC and MSD heaters and the diffusion pump heater or turbo pump at the correct time. It also lets you monitor temperatures in the MSD and indicates when to vent the MSD.

The MSD **will** be damaged by incorrect venting. A diffusion pump will backstream vaporized pump fluid onto the analyzer if the MSD is vented before the diffusion pump has fully cooled. A turbo pump will be damaged if it is vented while spinning at more than 50% of its normal operating speed.

---

**W A R N I N G**

**Make sure the GC/MSD interface and the analyzer zones are cool (below 100°C) before you vent the MSD. 100°C is still hot enough to burn skin; always wear cloth gloves when handling analyzer parts.**

---

**W A R N I N G**

**If you are using hydrogen as a carrier gas, the carrier gas flow must be off before turning off the MSD power. If the foreline pump is off, hydrogen will accumulate in the MSD and an explosion may occur. Read the *Hydrogen Carrier Gas Safety Guide* (5955-5398) before operating the MSD with hydrogen carrier gas.**

---

**C A U T I O N**

***Never* vent the MSD by allowing air in through either end of the foreline hose. Use the vent valve or remove the column nut and column.**

---

**C A U T I O N**

***Do not* vent or shut off the power on a diffusion pump MSD while the pump is hot. *Do not* vent while the turbo pump is still spinning at more than 50%.**

---

**C A U T I O N**

Column flow rate into the MSD during tuning or data acquisition should not exceed 2.0 ml/min for the diffusion pump MSD or 4.0 ml/min for the turbo pump MSD. Optimum sensitivity generally occurs at approximately half the maximum allowable flow.

---

***Moving or storing the MSD requires special care***

The best way to keep your MSD functioning properly is to keep it pumped down and hot, with carrier gas flow. If you plan to move or store your MSD, a few additional precautions are required. The MSD must remain upright at all times; this requires special caution when moving. The MSD should not be left vented for long periods.

## To view MSD analyzer temperature and vacuum status

*Software changes*

The software is revised periodically. If the steps in this procedure do not match your MSD ChemStation software, refer to the manuals and online help supplied with the software for more information.

- 1 In Instrument Control view, select Edit MS Tune Parameters from the Instrument menu.**
- 2 Select the tune file you plan to use with your method from the Load MS Tune File dialog box.**
- 3 Analyzer temperatures and vacuum status are displayed in the Zones field.**

Unless you have just begun the pumpdown process, the foreline pressure should be less than 300 mTorr, or the turbo pump should be running at least 80% speed. MSD heaters remain off as long as the diffusion pump is cold or the turbo pump is operating at less than 80%. Normally, the foreline pressure will be below 100 mTorr, or the turbo pump speed will be at 100%.

The MSD heaters turn off at the beginning of the vent cycle, and turn on at the end of the pumpdown cycle. Note that the reported setpoints will not change during venting or pumpdown, even though both the MSD zones are turned off.

To view MSD analyzer temperature and vacuum status

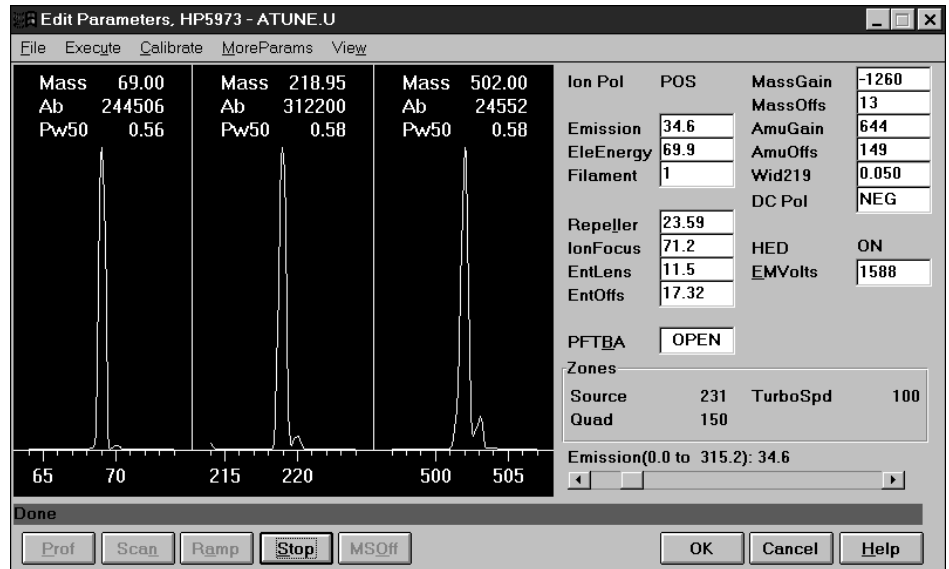

## To set monitors for MSD temperature and vacuum status

Monitors display the current value of a single instrument parameter. They can be added to the standard instrument control window. Monitors can be set to change color if the actual parameter value varies beyond a user-determined limit from the parameter setpoint. This procedure describes how to add monitors to your instrument control view.

### *Software changes*

The software is revised periodically. If the steps in this procedure do not match your MSD ChemStation software, refer to the manuals and online help supplied with the software for more information.

- 1 Select MS Monitors from the Instrument menu.**
- 2 In the Edit MS Monitors box, under Type, select Zone.**
- 3 Under Parameter, select MS Source and click Add.**
- 4 Under Parameter, select MS Quad and click Add.**
- 5 Under Parameter, select Foreline (or TurboSpd) and click Add.**

**6 Click OK.**

The new monitors will be stacked on top of each other in the lower right corner of the Instrument Control window. They must be moved for you to see them all.

**7 Click and drag each monitor to the desired position.**

See the accompanying illustration for an example of arranging the monitors.

**8 To make the new settings part of the method, select Save from the Method menu.**

## To set monitors for MSD temperature and vacuum status

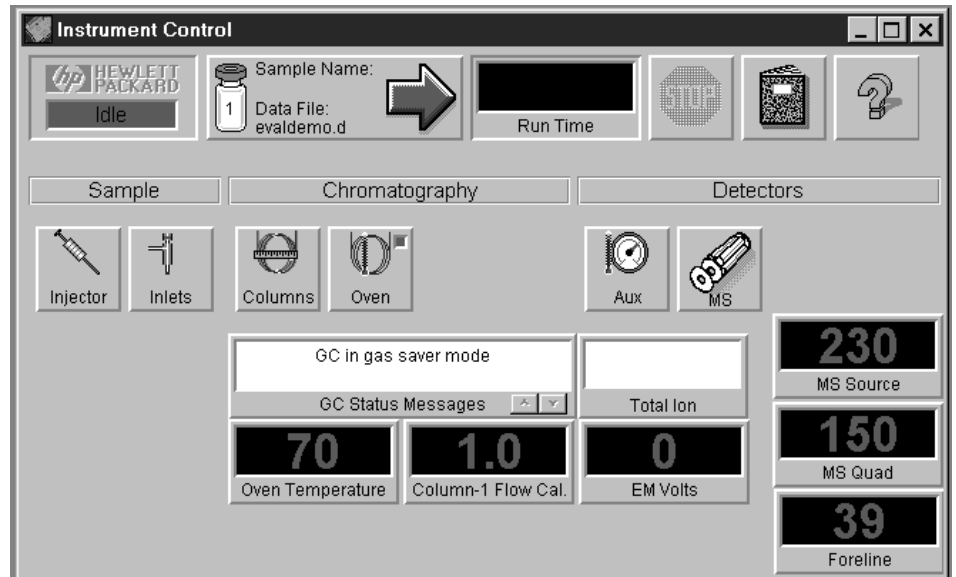

## To set the MSD analyzer temperatures

Setpoints for the MSD ion source and mass filter (quad) temperatures are stored in the current tune (\*.u) file. When a method is loaded, the setpoints in the tune file associated with that method are downloaded automatically.

### *Software changes*

The software is revised periodically. If the steps in this procedure do not match your MSD ChemStation software, refer to the manuals and online help supplied with the software for more information.

- 1 In Instrument Control view, select Edit MS Tune Parameters from the Instrument menu.**
- 2 Select the tune file you plan to use with your method from the Load MS Tune File dialog box.**
- 3 Select Temperatures from the MoreParams menu.**
- 4 Type the desired Source and Quad (mass filter) temperatures in the setpoint fields and click OK.**

Recommended settings for operation are:

Source: 230°C

Quad: 150°C

The GC/MSD interface, ion source, and quadrupole heated zones interact. The analyzer heaters may not be able to accurately control temperatures if the setpoint for one zone is much lower than that of an adjacent zone.

---

### **C A U T I O N**

---

Do not exceed 200°C for the quadrupole or 250°C for the source.

- 5 Click OK in the Edit Parameters window to apply the new temperature setpoints.**
- 6 When the Save MS Tune File dialog box appears, either click OK to save your changes to the same file or type a new file name and click OK.**

To set the MSD analyzer temperatures

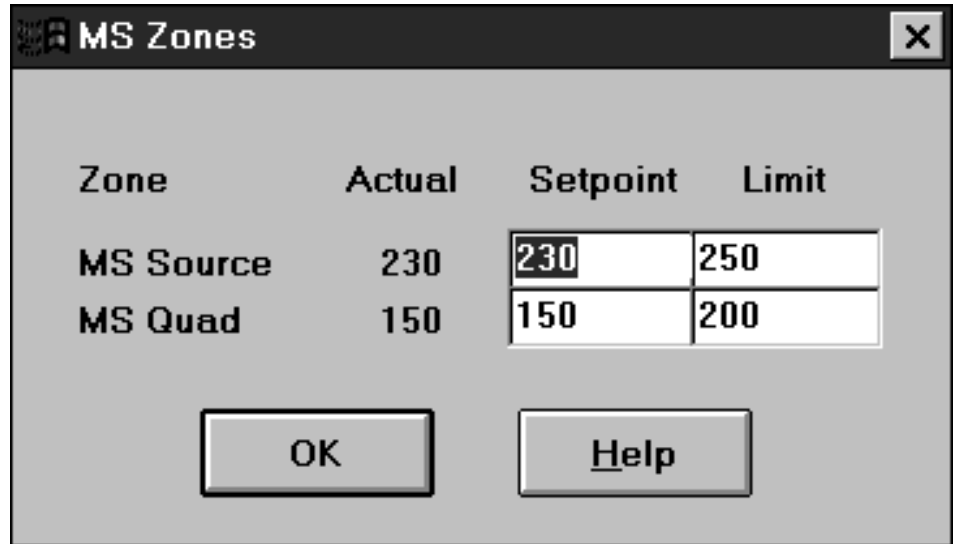

The screenshot shows a dialog box titled "MS Zones" with a close button (X) in the top right corner. The dialog contains a table with four columns: "Zone", "Actual", "Setpoint", and "Limit". There are two rows of data: "MS Source" and "MS Quad". The "Setpoint" column for "MS Source" is currently set to 230 and is highlighted with a cursor. Below the table are two buttons: "OK" and "Help".

Zone	Actual	Setpoint	Limit
MS Source	230	230	250
MS Quad	150	150	200

OK      Help

## To set the interface temperature from the ChemStation

### *Software changes*

The software is revised periodically. If the steps in this procedure do not match your MSD ChemStation software, refer to the manuals and online help supplied with the software for more information.

- 1 Select Instrument Control from the View menu.**
- 2 Click the Aux button to display the Instrument | Edit | Aux: (6890) window.**
- 3 Verify that MSD is selected under Type and Thermal Aux #2 is selected under Aux Channel.**
- 4 Turn the heater on, and type the setpoint in the Next °C column. Do not set temperature ramps.**
- 5 The typical setpoint is 280°C.**

The limits are 0°C and 350°C. A setpoint below ambient temperature turns off the interface heater.

---

### **CAUTION**

---

Never exceed the maximum temperature for your column.

- 6 Click Apply to download setpoints or click OK to download setpoints and close the window.**
- 7 To make the new settings part of the method, select Save from the Method menu.**

---

### **CAUTION**

---

Make sure that the carrier gas is turned on and the column has been purged of air before heating the GC/MSD interface or the GC oven.

## To set the interface temperature from the ChemStation

Instrument | Edit | Aux: (6890)

■ Oven Temp

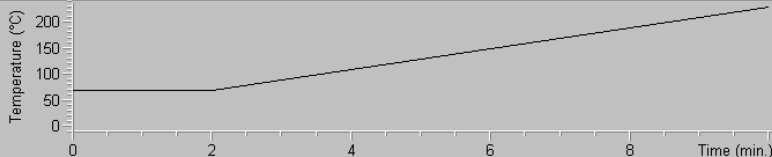

Temperature (°C)

Time (min.)

Plot...

Injector Valves Inlets Columns Oven Detectors Signals Aux Runtime Options

Aux Channel

Thermal Aux #1  
 Thermal Aux #2  
 Pres Aux #3  
 Pres Aux #4  
 Pres Aux #5

Description:

Heater

On    Actual: 280 °C

Type

Valve Box  
 MSD  
 AED  
 Unknown

Ramps	°C/min	Next °C	Hold min	Run Time
Initial		280	0.00	10.00
Ramp 1	0.00	0	0.00	
Ramp 2	0.00	0	0.00	
Ramp 3	0.00	0	0.00	

Apply

OK

Cancel

Help

## To monitor high vacuum pressure

*Materials needed:*

Gauge controller (HP 59864B)  
Triode gauge cable (8120-6573)

---

**W A R N I N G**

**Never connect or disconnect the cable from the triode gauge tube while the MSD is under vacuum. Risk of implosion and injury due to broken glass exists.**

---

**W A R N I N G**

**If you are using hydrogen as a carrier gas, do not turn on the triode gauge tube if there is any possibility that hydrogen has accumulated in the manifold. The triode gauge filament can ignite hydrogen. Read the *Hydrogen Carrier Gas Safety Guide* (5955-5398) before operating the MSD with hydrogen carrier gas**

- 1 Connect the gauge controller to the triode gauge tube (page 60).**
- 2 Start up and pump down the MSD (page 58).**
- 3 Switch on the power switch on the back of the gauge controller.**
- 4 Press and release the GAUGE button.**

After a few seconds, the pressure should be displayed.

Pressure is displayed in the format **XX-X** where **-X** is the base 10 exponent. Units are Torr.

The gauge controller will not turn on if the pressure in the MSD is above approximately  $8 \times 10^{-3}$  Torr. The gauge controller will display all 9s and then go blank. The triode gauge tube can measure pressures between approximately  $8 \times 10^{-3}$  and  $3 \times 10^{-6}$  Torr. The gauge controller is calibrated for nitrogen, but all pressures listed in this manual are for helium.

The largest influence on operating pressure is the carrier gas (column) flow. The following table lists typical pressures for various helium carrier gas flows. These pressures are approximate and will vary from instrument to instrument.

Table 2

---

**Typical MSD pressure readings for various helium carrier gas flow rates**

---

**Diffusion pump MSD**

---

Column flow (ml/min)	Triode gauge reading (Torr)	Foreline gauge reading (Torr)
1.0	$5.0 \times 10^{-5}$	40
1.5	$7.5 \times 10^{-5}$	53
2.0	$1.0 \times 10^{-5}$	66

---

**Turbo pump MSD**

---

Column flow (ml/min)	Triode gauge reading (Torr)
1.0	$1.5 \times 10^{-5}$
2.0	$3.0 \times 10^{-5}$
3.0	$4.5 \times 10^{-5}$
4.0	$6.0 \times 10^{-5}$

If the pressure is consistently higher than those listed, refer to the online help in the MSD ChemStation software for information on troubleshooting air leaks and other vacuum problems.

If the pressure rises above approximately  $8 \times 10^{-3}$  Torr, the gauge controller will turn off the triode gauge tube. The gauge tube **does not** turn back on automatically.

## To measure column flow linear velocity

*Materials needed:* Syringe

- 1 Set Data Acquisition for manual injection and selected ion monitoring (SIM) of  $m/z$  28.**
- 2 Click Prep Run.**
- 3 Inject about 1  $\mu$ l of air into the injection port and click Start Run.**
- 4 Wait until a peak elutes at  $m/z$  28.**

Note the retention time.

- 5 Calculate the average linear velocity.**

$$\text{Average linear velocity (cm/sec)} = \frac{100 L}{t}$$

where:

$L$  = length of the column in meters

$t$  = retention time in seconds

Be sure to account for any pieces of column broken off. A 1-meter section missing from a 25-meter column can yield a 4% error.

- 6 Use this value to verify the MSD ChemStation flow calculations (page 47).**

If the numbers disagree, click the **Change** button to calibrate the column dimensions.

- 7 To calculate the volumetric flow rate.**

$$\text{Volumetric flow rate (ml/min)} = \frac{0.785 D^2 L}{t}$$

where:

$D$  = internal column diameter in millimeters

$L$  = the column length in meters

$t$  = the retention time in minutes

## To calculate column flow

- 1 In the Instrument Control view, click the Columns icon.
- 2 Check that the correct column dimensions are entered.
- 3 Type the desired value in the pressure field.

Instrument | Edit | Columns: (6890)

■ Oven Temp

Temperature (°C)

Plot...

Time (min.)

Injector Valves Inlets **Columns** Oven Detectors Signals Aux Runtime Options

Column Mode: Const Flow  
 Inlet: Front  
 Detector: MSD  
 Outlet psi: Vacuum

Installed Column  
 Inventory#: AB001  
 (not calibrated)

Column Dimensions  
 Capillary 30.0 m x 250 µm x 0.25 µm

He Flow

	Setpoint	Actual	
Pressure:	8.8	8.8	psi
Flow:	1.0	1.0	ml/min
Average Velocity:	37		cm/sec

Flow	ml/min <sup>2</sup>	ml/min	Hold min	Run Time
Initial		1.0	0.00	10.00
Ramp 1	0.00	0.0	0.00	
Ramp 2	0.00	0.0	0.00	
Ramp 3	0.00	0.0	0.00	
Post Run			0.00	10.00

Change...  
 Apply  
 OK  
 Cancel  
 Help

- 4 If the Average Velocity displayed is different from that obtained on page 46, click the Change button to calibrate the column dimensions.

## To tune the MSD

### *Software changes*

The software is revised periodically. If the steps in this procedure do not match your MS ChemStation software, refer to the manuals and online help supplied with the software for more information.

**1 In the Instrument Control View, select Perform MS Autotune from the Instrument menu.**

**2 Select the tune program you wish to use.**

The tune will start immediately. For most applications, **Autotune** gives the best results. **Standard Spectra Tune** is not recommended, as it may reduce sensitivity. **Quick Tune** is used to adjust peak width, mass assignment, and abundance, without changing ion ratios. Always tune the MSD with the same column flow and the same analyzer temperatures that will be used for data acquisition.

**3 Wait for the tune to complete and to generate the report.**

Save your tune reports. To view history of tune results, select **View Tunes...** under the Qualify menu.

**4 To manually tune your MSD or to perform special autotunes, select Manual Tune from the View menu.**

In the Manual Tune view, you can manually adjust most tune parameters to suit special needs.

From the Tune menu, in addition to the tunes available from Instrument Control, you can select special autotunes for specific spectral results: **DFTPP Tune**, **BFB Tune**, or **Target Tune**.

See the manuals or online help provided with your MSD ChemStation software for additional information about tuning.

---

## To set the interface temperature from an HP 6890 GC

### 1 Press the Aux # key on the GC keypad.

### 2 Press 2.

By default, the GC/MSD interface is powered by heated zone Thermal Aux #2 on the HP 6890 Series GC. Verify that the display shows **THERMAL AUX 2 (MSD)**.

### 3 Use the number keys to type in the new temperature setpoint.

The typical setpoint is 280°C. The limits are 0°C and 350°C. A setpoint below ambient temperature turns off the interface heater.

---

#### **CAUTION**

---

Never exceed the maximum temperature of your column.

---

#### **CAUTION**

---

Make sure that the carrier gas is turned on and the column has been purged of air before heating the GC/MSD interface or the GC oven.

### 4 Press the Enter key to download the new setpoint.

If you want the new setpoint to become part of the current method, click **Save** under the Method menu. Otherwise, the first time a method is loaded, all the setpoints in the method will overwrite those set from the GC keyboard.

## To remove the MSD covers

*Materials needed:* Screwdriver, TORX T-15 (8710-1622)

The upper MSD cover is removed for venting and for many maintenance procedures. The lower MSD cover is removed to check the fluid level in the diffusion pump and for a few maintenance procedures. If you need to remove one of the MSD covers, follow these procedures:

### Upper MSD cover

- 1 Grasp the front of the upper MSD cover and lift up enough to disengage the front latch.**
- 2 Reach back and grasp the back edge of the upper MSD cover.**
- 3 Pull forward to disengage the spring latch.**

It may take a firm pull to disengage the latch.

To reinstall the upper MSD cover, reverse these steps.

### Lower MSD cover

- 1 Remove the upper MSD cover.**
- 2 Remove the 3 screws that hold the lower MSD cover in place.**
- 3 Move the cover left slightly to disengage it and then pull it straight forward.**

To reinstall the lower MSD cover, reverse these steps.

---

## **W A R N I N G**

---

Do not remove any covers other than the upper and lower MSD covers. Dangerous voltages are present under other covers.

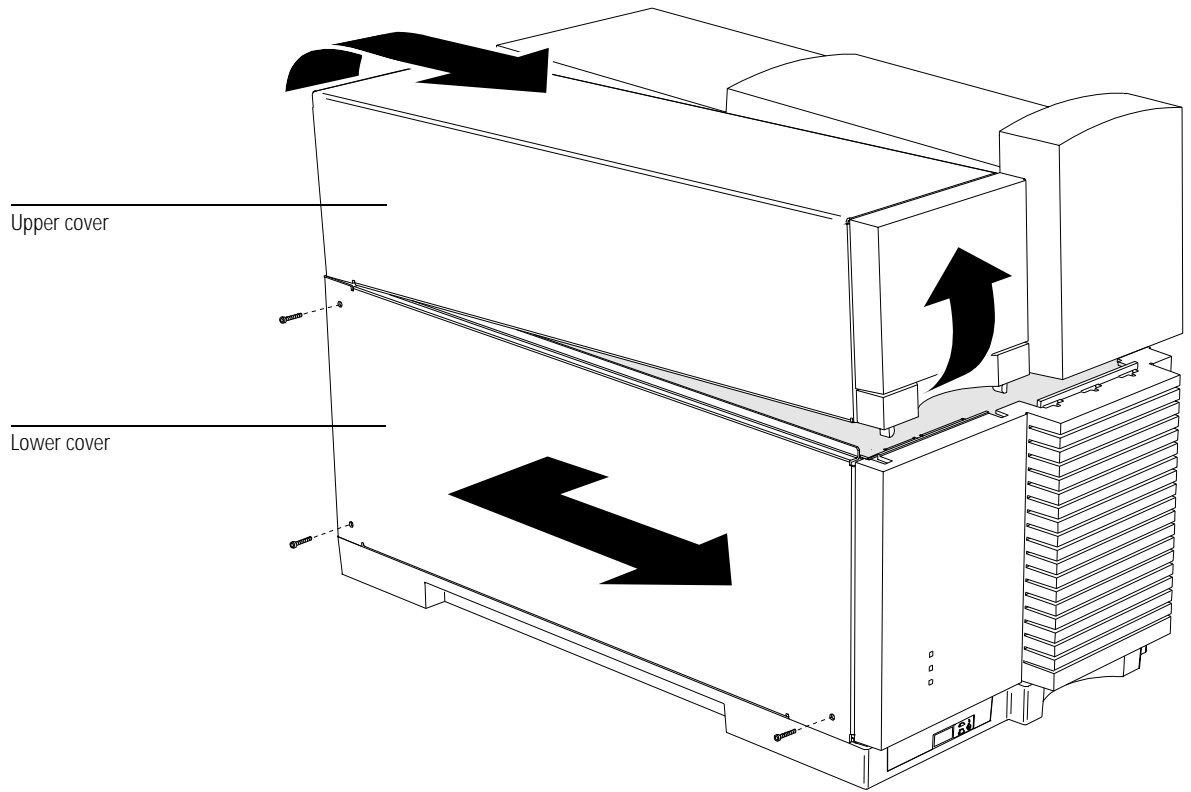

## To vent the MSD

### *Software changes*

The software is revised periodically. If the steps in this procedure do not match your MSD ChemStation software, refer to the manuals and online help supplied with the software for more information.

If the data system is not working correctly, the MSD can still be vented safely. See page 64.

**1 If your system is equipped with a gauge controller, switch off the triode gauge controller.**

**2 Select Diagnostics/Vacuum Control from the View menu.**

**3 Select Vent from the Vacuum menu. Follow the instructions presented.**

The vent program cools the GC/MSD interface heater and the GC oven. The program turns off the analyzer heaters and the high vacuum pump. The software will prompt you when it is safe to switch off the power.

---

### **W A R N I N G**

**If you are using hydrogen as a carrier gas, the carrier gas flow must be off before turning off the MSD power. If the foreline pump is off, hydrogen will accumulate in the MSD and an explosion may occur. Read the *Hydrogen Carrier Gas Safety Guide* (5955-5398) before operating the MSD with hydrogen carrier gas.**

---

### **C A U T I O N**

Be sure the GC oven and the GC/MSD interface are cool before turning off carrier gas flow.

**4 When prompted, turn off the MSD power switch.**

**5 Unplug the MSD power cord.**

**6 Remove the upper MSD cover (page 50).**

**7 Turn the vent valve knob counterclockwise *only* 1/4 to 3/4 turns to admit air into the vacuum manifold.**

Do **not** turn the knob too far. Be sure to retighten the knob before pumping down.

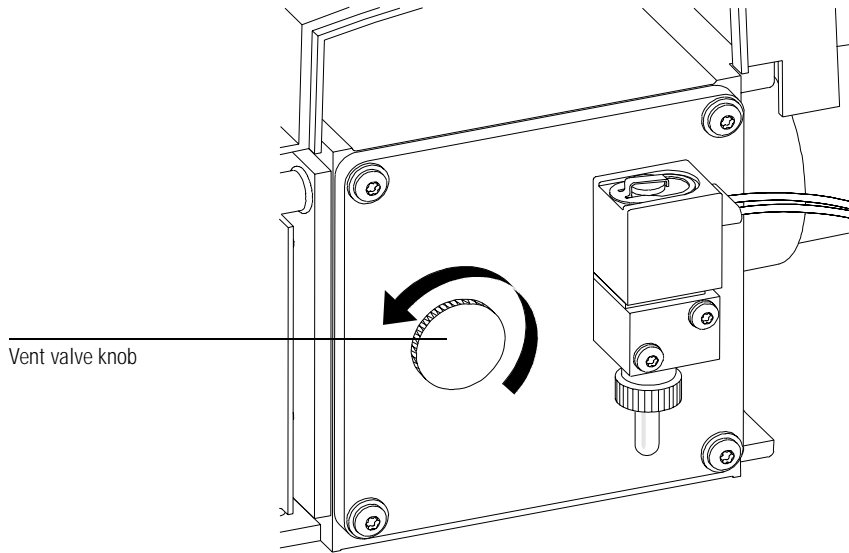

---

**W A R N I N G**

---

At 100°C, analyzer parts are still hot enough to burn bare skin. *Do not handle* hot parts.

---

**CAUTION**

---

Always wear clean gloves while handling any parts that go inside the vacuum manifold.

Vent valve knob

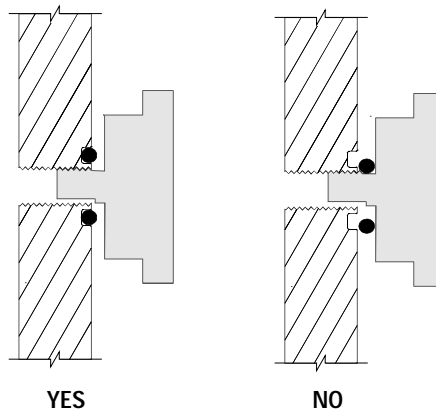

To open the vacuum manifold

---

## To open the vacuum manifold

*Materials needed:*

Gloves, clean, lint-free  
large (8650-0030)  
small (8650-0029)  
Wrist strap, anti-static  
small (9300-0969) swe  
medium (9300-1257)  
large (9300-0970)

---

**CAUTION**

Electrostatic discharges to analyzer components are conducted to the side board where they can damage sensitive components. Wear a grounded anti-static wrist strap and take other anti-static precautions (see page 100) before you open the vacuum manifold.

---

- 1 Vent the MSD (page 52).**
- 2 Disconnect the side board control cable and the source power cable from the side board.**
- 3 Loosen the side plate thumbscrews, if they are fastened.**

The rear side plate thumbscrew should be unfastened during normal use. It is only fastened during shipping. The front side plate thumbscrew should only be fastened for CI operation or if hydrogen or other flammable or toxic substances are used for carrier gas.

---

**WARNING**

**The analyzer, GC/MSD interface, and other components in the vacuum manifold operate at very high temperatures. Do not touch any part until you are sure it is cool.**

---

---

**CAUTION**

Always wear clean gloves to prevent contamination when working in the vacuum manifold.

---

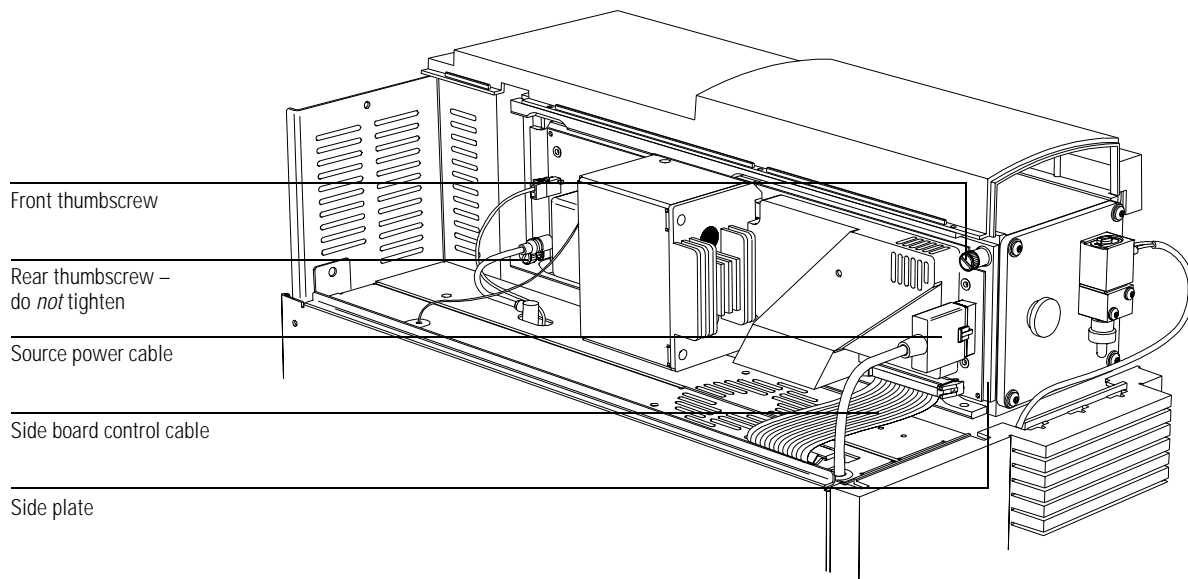
**To open the vacuum manifold****4 Gently open the side plate.**

---

**CAUTION**

---

If you feel resistance, stop. Do not try to force the side plate open. Applying force will ruin the side plate. Verify that MSD is vented. Verify that both the front and rear side plate screws are completely loose.

## To close the vacuum manifold

*Materials needed:* Gloves, clean, lint-free  
large (8650-0030)  
small (8650-0029)

**1 Make sure all the internal analyzer electrical leads are correctly attached.**

**2 Check the side plate O-ring.**

Make sure the O-ring has a *very* light coat of Apiezon high vacuum grease. If the O-ring is very dry, it may not seal well. If the O-ring looks shiny, it has too much grease on it. See page 140 for instructions for lubricating the side plate O-ring.

**3 Close the side plate.**

**4 Reconnect the side board control cable and source power cable to the side board.**

**5 Make sure the vent valve is closed.**

**6 Pump down the MSD (page 58).**

**7 Gently hand tighten the front side plate thumbscrew**

This is only necessary for CI MSDs, or if hydrogen or other flammable or toxic substance is used for carrier gas.

---

### W A R N I N G

**This thumbscrew must be fastened for CI operation or if hydrogen (or other hazardous gas) is being used as the GC carrier gas. In the unlikely event of an explosion, it may prevent the side plate from opening.**

---

---

### C A U T I O N

Do not overtighten the thumbscrew; it can cause air leaks or prevent successful pumpdown. Do not use a screwdriver to tighten the thumbscrew.

---

**8 Once the MSD has pumped down, reinstall the upper MSD cover.**

Wait until after pumpdown to reinstall the upper MSD cover.

---

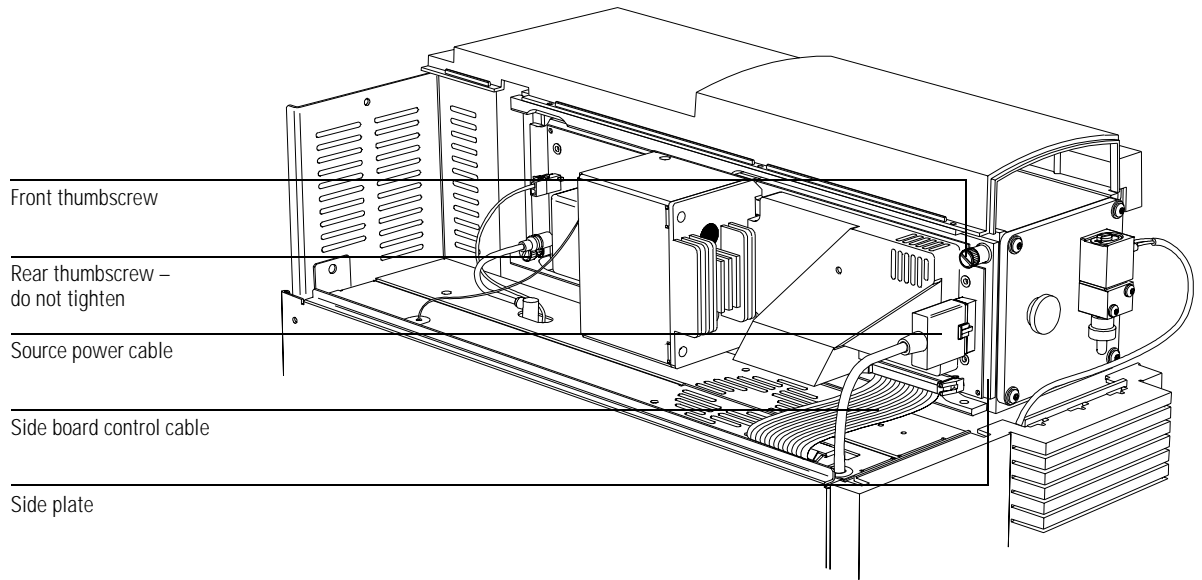

## To pump down the MSD

### *Software changes*

The software is revised periodically. If the steps in this procedure do not match your MSD ChemStation software, refer to the manuals and online help supplied with the software for more information.

---

### **W A R N I N G**

**Make sure your MSD meets *all* the conditions listed in the introduction to this chapter (page 32) before starting up and pumping down the MSD. Failure to do so can result in personal injury.**

---

### **W A R N I N G**

**If you are using hydrogen as a carrier gas, do not start carrier gas flow until the MSD has been pumped down. If the vacuum pumps are off, hydrogen will accumulate in the MSD and an explosion may occur. Read the *Hydrogen Carrier Gas Safety Guide* (5955-5398) before operating the MSD with hydrogen carrier gas.**

- 1 Select Diagnostics/Vacuum Control from the View menu.**
- 2 Select Pump Down from the Vacuum menu.**
- 3 When prompted, switch on the MSD.**

Press on the sideplate while turning on the MSD to ensure a good seal. The rough pump will make a gurgling noise. This noise should stop within a minute. If the noise continues, there is a **large** air leak in your system, probably at the interface column nut, the vent valve, or the sideplate.

---

### **C A U T I O N**

Continuing the pumpdown with a large air leak can damage the MSD. Newer MSDs will shut down the foreline pump if a large leak is present.

- 4 Click OK.**

Within 10 to 15 minutes the diffusion pump should be hot, or the turbo pump speed up to 80%. If the MSD does not pump down correctly, see the online help for information on troubleshooting air leaks and other vacuum problems.

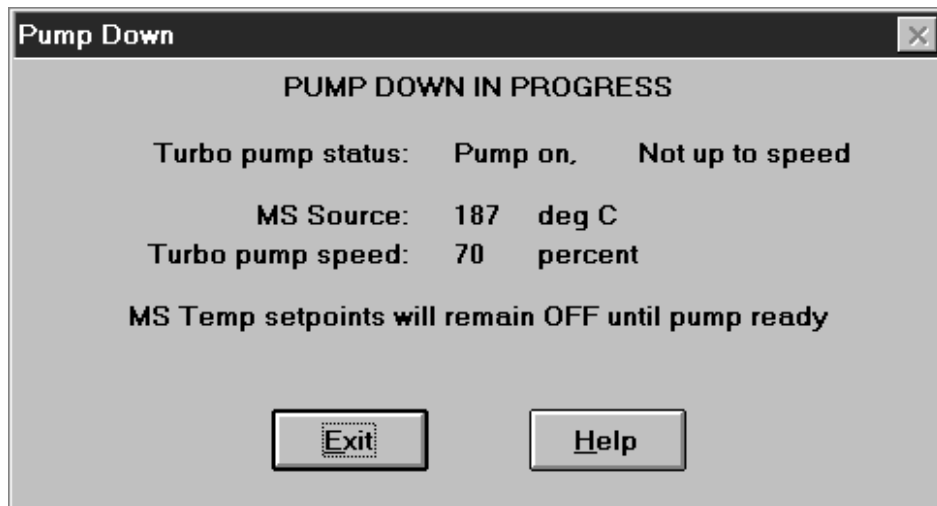

- 5 The software will prompt you to turn on the GC/MSD interface heater and GC oven. Click OK when you have done so.**

The software will turn on the ion source and mass filter (quad) heaters. The temperature setpoints are stored in the current autotune (\*.u) file.

---

**CAUTION**

---

Do not turn on any heated zones until carrier gas flow is on. Heating a column with no carrier gas flow will damage the column.

- 6 After the message Okay to run appears, wait two hours for the MSD to reach thermal equilibrium.**

Data acquired before the MSD has reached thermal equilibrium may not be reproducible.

- 7 Reinstall the MSD top cover.**

The top cover was removed during the vent procedure.

To connect the optional gauge controller

---

## To connect the optional gauge controller

*Materials needed:*

Gauge controller (HP 59864B)  
Power cord  
Triode gauge cable (8120-6573)

---

**W A R N I N G**

**Never connect or disconnect the cable from the triode gauge tube while the MSD is under vacuum. Risk of implosion and injury due to broken glass exists.**

---

**C A U T I O N**

Do *not* use an HP 59864A (older model) triode gauge controller during data acquisition. This model can be used for diagnostic purposes *only*.

---

**C A U T I O N**

Be sure to orient the cable and the gauge tube as illustrated. Excessive force on the pins can break the tube.

- 1 Connect the triode gauge cable to the triode gauge tube.**
- 2 Connect the other end of the triode gauge cable to the gauge controller.**
- 3 Connect the power cord to the gauge controller.**
- 4 Connect the other end of the power cord to an appropriate electrical outlet.**

If you wish to share one controller among MSDs, obtain one cable for each instrument. Leave a cable connected to the triode gauge tube on each MSD. This will avoid having to vent the MSD before connecting the controller.

To connect the optional gauge controller

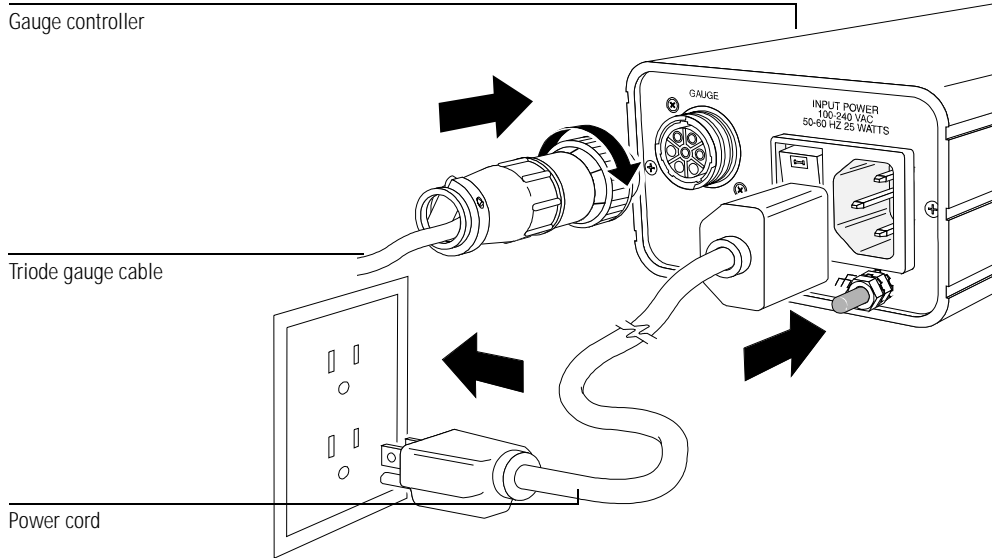
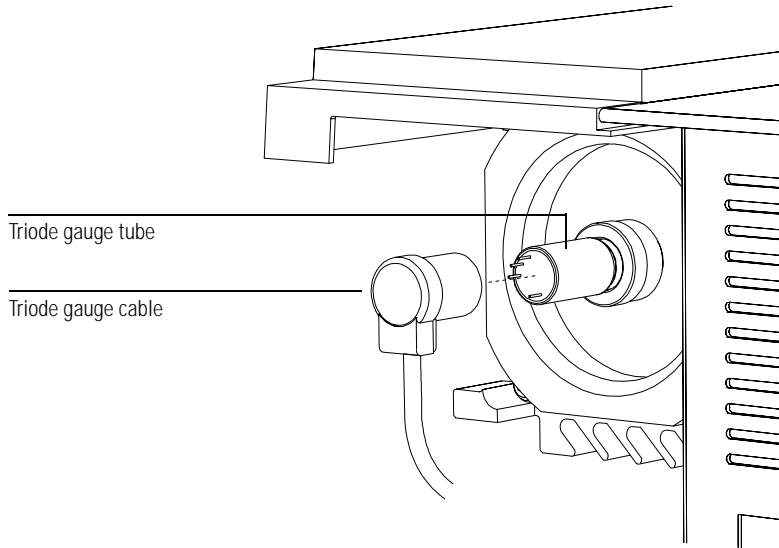

## To move or store the MSD

*Materials needed:*

Ferrule, blank (5181-3308)  
Interface column nut (05988-20066)  
Wrench, open-end, 1/4-inch × 5/16-inch (8710-0510)

- 1 Vent the MSD (page 52).**
- 2 Remove the column and install a blank ferrule and interface nut.**
- 3 Tighten the vent valve.**
- 4 If the MSD has a gauge controller, disconnect the cable from the triode gauge tube.**
- 5 Move the MSD away from the GC (page 112).**  
Unplug the GC/MSD interface heater cable from the GC.
- 6 Remove the upper MSD cover (page 50).**
- 7 Tighten the side plate thumbscrews to “finger tight”.**

---

**CAUTION**

---

Do not overtighten the side plate thumbscrews. Overtightening will strip the threads in the vacuum manifold. It will also warp the side plate and cause leaks.

- 8 Plug the MSD power cord in.**
  - 9 Switch the MSD on to establish a rough vacuum.**  
Verify that the foreline pressure is below 300 mTorr or the turbo pump speed greater than 50%.
  - 10 Switch the MSD off.**
  - 11 Reinstall the upper MSD cover.**
  - 12 Disconnect the HP-IB, remote, and power cables.**
-

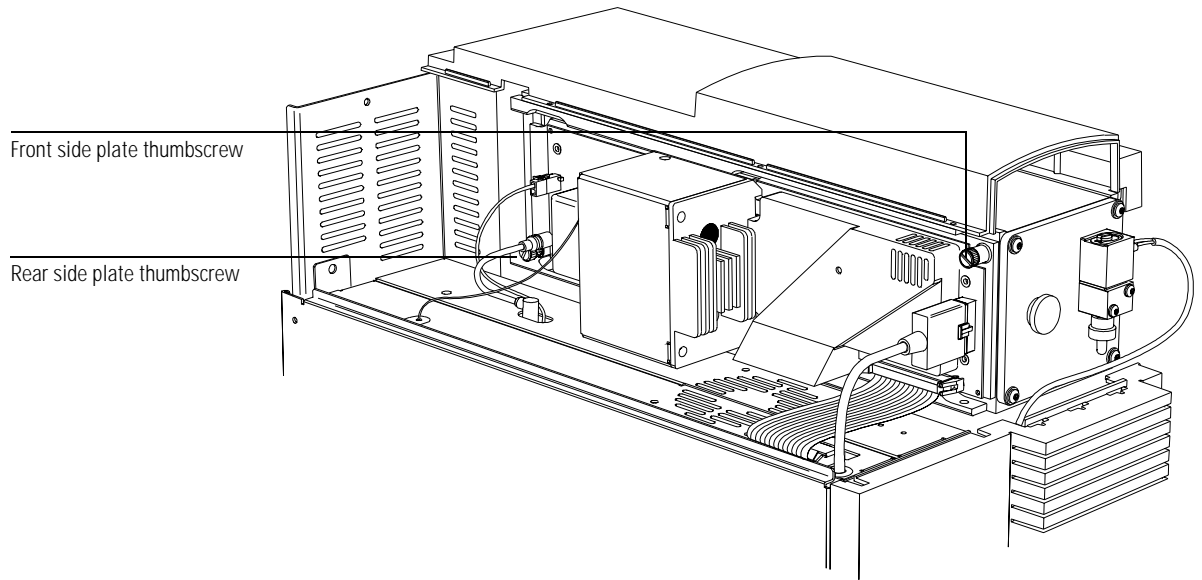

The MSD can now be stored or moved. The foreline pump cannot be disconnected. It must be moved with the MSD. Make sure the MSD remains upright and is never tipped on its side or inverted.

---

**CAUTION**

---

The MSD must remain upright at all times. If you need to ship your MSD to another location, contact your Hewlett-Packard service representative for advice about packing and shipping.

## To vent the MSD without the ChemStation

If the MSD ChemStation is functioning, use the procedure on page 52. This procedure should **only** be used if it is absolutely necessary.

- 1 If your system is equipped with a gauge controller, switch off the triode gauge tube and gauge controller.**
- 2 From the GC keypad, turn off the GC zone controlling the GC/MSD interface heater and set the GC oven to 30°C (see page 49).**
- 3 Disconnect the HIVAC POWER cable from the back panel.**

This turns off the MS heaters and the diffusion pump heater or turbo pump, but the cooling fans and foreline pump stay on.
- 4 After 45 minutes, turn off the MSD power switch.**
- 5 Unplug the MSD power cord.**

---

### W A R N I N G

**If you are using hydrogen as a carrier gas, the carrier gas flow must be off before turning off the MSD power. If the foreline pump is off, hydrogen will accumulate in the MSD and an explosion may occur. Read the *Hydrogen Carrier Gas Safety Guide* (5955-5398) before operating the MSD with hydrogen carrier gas.**

---

### C A U T I O N

Be sure the GC oven and the GC/MSD interface are cool before turning off carrier gas flow.

- 6 Reconnect the HIVAC POWER cable.**
- 7 Remove the upper MSD cover (page 50).**
- 8 Turn the vent valve knob counterclockwise to admit air into the vacuum manifold.**

Do not remove the knob. Be sure to retighten the knob before pumping down.

### See Also

*To open the vacuum manifold*, page 54

---

General symptoms, 68  
Chromatographic symptoms, 70  
Mass spectral symptoms, 75  
Pressure symptoms, 79  
Temperature symptoms, 82  
Error messages, 84  
Air leaks, 89  
Contamination, 90

---

## Troubleshooting the MSD

How to identify the symptoms and causes of problems in your MSD

---

# Troubleshooting the MSD

This chapter is a quick reference to symptoms and possible causes of the most common problems experienced by the HP 5973 Mass Selective Detector (MSD). Related symptoms are grouped in these categories:

- General symptoms
- Chromatographic symptoms
- Mass spectral symptoms
- Pressure symptoms
- Temperature symptoms
- Error messages
- Contamination
- Air leaks

For each symptom, one or more possible causes are listed. The possible causes listed are not in a strict order. In general, however, the possible causes listed first are the most likely causes **or** the easiest to check and correct.

This section is only a quick reference. No corrective actions are listed for the possible causes for each symptom. For more extensive troubleshooting information, see the *Troubleshooting (HP 5973 MSD)* section in the online help of the MSD ChemStation software. The online troubleshooting provides more explanation and, in many cases, corrective actions.

---

## W A R N I N G

**This chapter does not include corrective actions for the possible causes listed. Some of the corrective actions required may be dangerous if performed incorrectly. Do not attempt any corrective actions unless you are sure you know the correct procedure and the dangers involved. See the *Troubleshooting (HP 5973 MSD)* section in the online help and the other chapters in this manual for more information.**

---

If the material in this chapter and in the online help proves insufficient to help you diagnose a problem, contact your Hewlett-Packard service representative.

#### General symptoms

---

## General symptoms

This section describes symptoms you might observe when first turning on the GC/MSD system. All of these symptoms would prevent operation of the system.

### **GC does not turn on**

This refers to a condition in which nothing happens when the GC is switched on. The GC fans do not turn on and the keypad display does not light.

- Disconnected GC power cord
- No voltage or incorrect voltage at the electrical outlet
- Failed fuse in the GC
- GC power supply is not working correctly

### **MSD does not turn on**

This refers to a condition in which nothing happens when the MSD is switched on. The foreline pump does not start. The cooling fan for the high vacuum pump does not turn on. The status LEDs on the front of the MSD do not light.

- Disconnected MSD power cord
- No voltage or incorrect voltage at the electrical outlet
- Failed primary fuses
- MSD electronics are not working correctly

### **Foreline pump is not operating**

This refers to a condition where the MSD is receiving power (the fan is operating and the power LED on the status display is lit) but the foreline pump is not operating.

- Disconnected foreline pump power cord
- Malfunctioning foreline pump

### **Fan for the high vacuum pump is not operating**

This refers to a condition where the MSD is on (at least the foreline pump is operating) but the fan for the high vacuum pump is not working. You can determine this by listening or by putting your hand next to the ventilation slots on the front of the instrument. You should be able to feel air being pulled into the MSD.

- Disconnected fan cable
- Disconnected high vacuum signal cable (*never* connect or disconnect this cable while the MSD is on)
- Malfunctioning fan

### **MSD is on but the status LEDs are all blinking**

This is normal when the MSD is initially turned on. The status LEDs blink until the data system software is started or the pumpdown cycle is initiated. The data system then downloads the instrument control software to the HP-IB/MS control card. When this occurs, the status LEDs will all light for a few seconds and then begin to operate normally, leaving the power LED on and the others off. If the status LEDs do not stop blinking, or if the status LEDs are all blinking at a time other than startup, one of the following may be the cause:

- Temporary power failure interrupted communications
- Bad connection between the MSD and the data system
- Software malfunction
- MSD electronics are not working correctly

If the status LEDs continue to blink there will usually also be an error message in the MSD ChemStation software.

### **MSD turns on but then the foreline pump shuts off**

MSDs with serial number XX820XXXXX and above will shut down both the foreline pump and the high vacuum pump if the system fails to pump down correctly. This is usually because of a large air leak: either the sideplate has not sealed correctly or the vent valve is still open. This feature helps prevent the foreline pump from sucking air through the system, which can damage the analyzer and pump.

---

## Chromatographic symptoms

This section describes symptoms you may observe in the chromatograms generated by data acquisition. In general, these symptoms do not prevent you from operating your GC/MSD system. They indicate, however, that the data you are acquiring may not be the best data obtainable. These symptoms can be caused by instrument malfunctions but are more likely caused by incorrect chromatographic technique.

Two of the symptoms: *If sensitivity is low* and *If repeatability is poor*, also apply to mass spectral data.

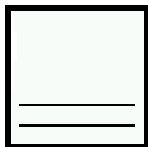

### No peaks

If an analysis shows no chromatographic peaks, only a flat baseline or minor noise, run one of the automated tune programs. If the MSD passes tune, the problem is most likely related to the GC. If the MSD does not pass tune, the problem is most likely in the MSD.

### *Passes tune*

- Incorrect sample concentration
- No analytes present
- Syringe missing from the ALS or not installed correctly
- Injection accidentally made in split mode instead of splitless mode
- Empty or almost empty sample vial
- Dirty injection port
- Leaking injection port\*
- Loose column nut at the injection port\*

\* These could cause a fault condition in the GC that would prevent the GC from operating.

***Does not pass tune***

- Calibration vial is empty
- Excessive foreline or vacuum manifold pressure
- Very dirty ion source
- Calibration valve is not working correctly
- Bad signal cable connection
- Filament has failed or is not connected correctly
- Bad ion source wiring connection
- Bad detector wiring connection
- Failed electron multiplier horn

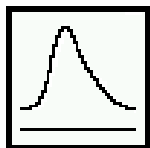

**Peaks are tailing**

- Active sites in the sample path
- Injection is too large
- Incorrect injection port temperature
- Insufficient column flow
- GC/MSD interface temperature is too low
- Ion source temperature is too low

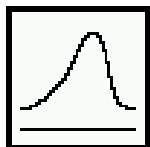

**Peaks are fronting**

- Column film thickness mismatched with analyte concentration (column overload)
- Initial oven temperature is too low
- Active sites in the sample path
- Injection is too large
- Injection port pressure too high
- Insufficient column flow

### Chromatographic symptoms

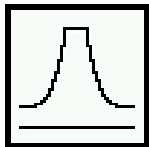

#### Peaks have flat tops

- Insufficient solvent delay
- Incorrect scale on the display
- Injection is too large
- Electron multiplier voltage is too high

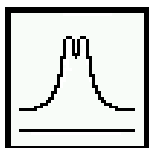

#### Peaks have split tops

- Bad injection technique
- Injection is too large

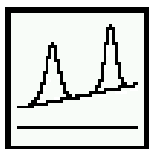

#### Baseline is rising

- Column bleed
- Other contamination

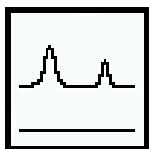

#### Baseline is high

- Column bleed
- Other contamination
- Electron multiplier voltage is too high

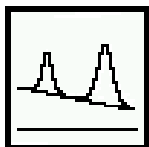

#### Baseline is falling

A falling baseline indicates contamination is being swept away. Wait until the baseline reaches an acceptable level. Common causes include:

- Residual water air and water from a recent venting
- Column bleed
- Septum bleed
- Splitless injection time too long (inlet is not properly swept, resulting in excess solvent on the column and slow solvent decay)

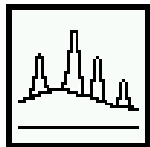

### Baseline wanders

- Insufficient carrier gas supply pressure\*
- Malfunctioning flow or pressure regulator\*
- Intermittent leak in the injection port\*

\* These could cause a fault condition in the GC that would prevent the GC from operating.

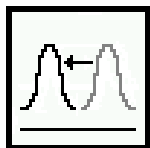

### Retention times for all peaks drift – shorter

- Column has been shortened
- Initial oven temperature was increased
- Column is getting old

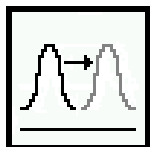

### Retention times for all peaks drift – longer

- Column flow has been reduced
- Initial oven temperature was decreased
- Active sites in the sample path
- Leaks in the injection port\*

\* This could cause a fault condition in the GC that would prevent the GC from operating.

#### Chromatographic symptoms

##### Poor sensitivity

- Incorrect tuning
- Tune file that does not match the type of analysis
- Repeller voltage is too low
- Incorrect temperatures (oven, GC/MSD interface, ion source, or mass filter)
- Incorrect sample concentration
- Leaking injection port\*
- Dirty injection port
- Incorrect split ratio
- Purge off time in splitless mode is too short
- Excessive pressure in the MSD
- Dirty ion source
- Air leak
- Poor filament operation
- Detector (HED electron multiplier) is not working correctly
- Incorrect mass filter polarity

\* This could cause a fault condition in the GC that would prevent the GC from operating.

##### Poor Repeatability

- Dirty syringe needle
- Dirty injection port
- Leaking injection port\*
- Injection is too large
- Loose column connections
- Variations in pressure, column flow, and temperature
- Dirty ion source
- Loose connections in the analyzer
- Ground loops

\* This could cause a fault condition in the GC that would prevent the GC from operating.

## Mass spectral symptoms

This section describes symptoms you might observe in mass spectra. Some of these symptoms will appear in the mass spectra of samples. Others you will observe only in a tune report. Some of these symptoms have causes that can be corrected by the operator. Others, however, require service by a Hewlett-Packard service representative.

Two symptoms listed under Chromatographic symptoms: *If sensitivity is poor* and *If repeatability is poor*, also apply to mass spectra.

### **Isotopes are missing or isotope ratios are incorrect**

- Peaks are too wide or too narrow
- Scan speed is too high (scan mode)
- Dwell time is too short (SIM mode)
- Electron multiplier voltage is too high
- Repeller voltage is too high
- High background
- Dirty ion source

### **High background**

- Pressure in the vacuum manifold is too high
- Air leak
- Contamination

### **High abundances at $m/z$ 18, 28, 32, and 44 or at $m/z$ 14 and 16**

- System was recently vented (residual air and water)
- Air leak

Large peaks at  $m/z$  14 and 16 are symptomatic of especially large leaks.

#### Mass spectral symptoms

##### **Mass assignments are incorrect**

Small shape changes at the top of the mass peaks can cause 0.1 amu shifts in mass assignments. Shifts greater than 0.2 amu indicate a possible malfunction.

- MSD has not had enough time to reach thermal equilibrium
- Large variations in the temperature of the laboratory
- MSD has not been tuned recently, or at the temperature at which it is operating
- Incorrect tune file (inappropriate parameters)

##### **Peaks have precursors**

The tune report lists the size of the precursors for the tune masses. Small precursors are not unusual. There are no specifications for acceptable or unacceptable precursor size. If the precursors are unacceptably large for your application, one of the following may be responsible:

- Repeller voltage is too high
- Peaks are too wide
- Incorrect dc polarity on the quadrupole mass filter
- Dirty quadrupole mass filter

##### **Peak widths are inconsistent**

- MSD has not had enough time to reach thermal equilibrium
- Large variations in the temperature of the laboratory
- Incorrect tuning
- Calibration vial is empty or almost empty
- Calibration valve is not working correctly
- Dirty ion source
- Electron multiplier is nearing the end of its useful lifetime
- Ground loop

### Relative abundance of $m/z$ 502 is less than 3%

Autotune should give an  $m/z$  502 relative abundance greater than 3%. The relative abundance of  $m/z$  502 can, however, vary a great deal depending on column flow, ion source temperature, and other variables. As long as relative abundance is above 3%, the stability of the relative abundance is more important than the absolute value. If you observe significant changes in the relative abundance of  $m/z$  502 for a fixed set of operating parameters, there may be a problem. The charts in the MSD ChemStation software are useful for identifying changes. Select **View Tunes** from the Qualify menu in the Instrument Control view.

Low **relative** abundance of  $m/z$  502 should not be confused with low **absolute** abundances at high masses. Sensitivity at high masses can be excellent even if the relative abundance of  $m/z$  502 is near 3%. If your MSD produces low absolute abundances at high masses, refer to the symptom *High mass sensitivity is poor*.

Tune programs other than autotune have different relative abundance targets. The DF1TPP and BFB target tune programs tune the HP 5973 MSD to achieve about a 0.8% ratio of  $m/z$  502/69.

- Tune program/tune file has a different relative abundance target (3% only applies to Autotune)
- Not enough time for the MSD to warm up and pump down
- Vacuum manifold pressure is too high
- Ion source temperature is too high
- Column (carrier gas) flow is too high
- Poor filament operation
- Dirty ion source
- Air leak
- Incorrect dc polarity on the quadrupole mass filter

### Spectra look different from those acquired with other HP MSDs

Ion ratios are different from those in older HP MSDs. This is due to the HED detector, and is normal. To get spectra similar to older MSDs, use **Standard Spectra Tune**, available in the Manual Tune view.

#### Mass spectral symptoms

##### High mass sensitivity is poor

This refers to a condition where the **absolute** abundance at the upper end of the mass range is poor. Absolute abundance should not be confused with the **relative** abundance (percentage) of  $m/z$  502 to  $m/z$  69. Sensitivity at high masses can be excellent even if the relative abundance of  $m/z$  502 is low.

- Wrong tune program
- Wrong tune file
- Repeller voltage is too low
- Not enough time for the MSD to warm up and pump down
- Vacuum manifold pressure is too high
- Column (carrier gas) flow is too high
- Poor filament operation
- Dirty ion source
- Air leak
- Incorrect dc polarity on the quadrupole mass filter

---

## Pressure symptoms

This section describes unusual pressure readings and their possible causes. The symptoms in this section are based on typical pressures. At typical column flow rates (0.1 - 2.0 ml/minute), the foreline pressure will be approximately 20 to 100 mTorr. The vacuum manifold pressure will be approximately  $1 \times 10^{-6}$  to  $1.4 \times 10^{-4}$  Torr. These pressures can vary widely from instrument to instrument so it is very important that you are familiar with the pressures that are typical for your instrument at given carrier gas flows.

The foreline pressures listed can only be measured on diffusion pump-equipped systems. Turbomolecular pumps are controlled according to their speed and do not have foreline pressure gauges. The vacuum manifold pressures can only be measured if your system is equipped with the optional gauge controller.

### Foreline pressure is too high

If the pressure you observe is above 100 mTorr, or if the pressure you observe for a given column flow has increased over time, check the following:

- Column (carrier gas) flow is too high
- Air leak (usually the sideplate is not pushed in or vent valve is open)
- Foreline pump oil level is low or oil is contaminated
- Foreline hose is constricted
- Foreline gauge is not working correctly
- Foreline pump is not working correctly

### Vacuum manifold pressure is too high

If the pressure you observe is above  $1.4 \times 10^{-4}$  Torr, or if the pressure you observe for a given column flow has increased over time, check the following:

- Column (carrier gas) flow is too high
- Air leak
- Foreline pump is not working correctly (see *Foreline pressure is too high*)
- Diffusion pump fluid level is low or fluid is contaminated
- Turbomolecular pump is not working correctly

#### Pressure symptoms

##### **Foreline pressure is too low**

If the pressures you observe are below 20 mTorr, check for the following:

- Column (carrier gas) flow is too low
- Column plugged or crushed by an overtightened nut
- Empty or insufficient carrier gas supply\*
- Bent or pinched carrier gas tubing\*
- Foreline gauge is not working correctly

\* These could create a fault condition in the GC that would prevent the GC from operating.

##### **Vacuum manifold pressure is too low**

If the pressures you observe are below  $1 \times 10^{-6}$  Torr, check for the following:

- Column (carrier gas) flow is too low
- Column plugged or crushed by overtightened nut
- Empty or insufficient carrier gas supply\*
- Bent or pinched carrier gas tubing\*

\* These could create a fault condition in the GC that would prevent the GC from operating.

##### **Gauge controller displays 9.9+9 and then goes blank**

This indicates the pressure in the vacuum manifold is above  $8 \times 10^{-3}$  Torr.

- Solvent peak from an on-column injection
- MSD has not had enough time to pump down
- Excessive foreline pressure
- Bad connection or bad cable between the triode gauge and gauge controller
- Diffusion pump fluid level is low or fluid is contaminated
- Triode gauge tube has failed
- Line voltage too low
- Turbomolecular pump is not working correctly

**Power indicator on the gauge controller does not light**

- Unplugged gauge controller power cord
- Incorrect or inadequate line voltage at the electrical outlet
- Failed gauge controller fuse

## Temperature symptoms

The MSD has three heated zones:

- Ion source (**Source** in the MSD ChemStation software)
- Mass filter (**Quad** in the MSD ChemStation software)
- GC/MSD interface (**Thermal Aux #2** in the MSD ChemStation software)

Each of these heated zones has a heater cartridge and temperature sensor. The ion source and mass filter are powered and controlled by the MSD. The GC/MSD interface is powered and controlled by the GC.

### **Ion source will not heat up**

- High vacuum pump is off or has not reached normal operating conditions\*
- Incorrect temperature setpoint
- Ion source has not had enough time to reach temperature setpoint
- Ion source heater cartridge is not connected\*
- Ion source temperature sensor is not connected\*
- Ion source heater failed (burned out or shorted to ground)\*
- Ion source temperature sensor failed\*
- Source power cable is not connected to the side board\*
- MSD electronics are not working correctly

\* These will cause an error message

### **Mass filter (quad) heater will not heat up**

- High vacuum pump is off or has not reached normal operating conditions\*
- Incorrect temperature setpoint
- Mass filter has not had enough time to reach temperature setpoint
- Mass filter heater cartridge is not connected\*
- Mass filter temperature sensor is not connected\*
- Mass filter heater failed (burned out or shorted to ground)\*
- Mass filter temperature sensor failed\*
- Source power cable is not connected to the sideboard\*
- MSD electronics are not working correctly

\* These will cause an error message

### **GC/MSD interface will not heat up**

- Incorrect setpoint
- Setpoint entered in wrong heated zone
- GC/MSD interface has not had enough time to reach temperature setpoint
- GC is off
- GC experienced a fault and needs to be reset\*
- GC/MSD interface heater/sensor cable is not connected\*
- GC/MSD heater failed (burned out)\*
- GC/MSD sensor failed\*
- GC electronics are not working correctly\*

\* These will cause a GC error message. GC error messages are described in the documentation supplied with your GC.

## Error messages

Sometimes, a problem in your MSD will cause an error message to appear in the MSD ChemStation software. Some error messages appear only during tuning. Other messages will appear during tuning or data acquisition. Sometimes, instead of a message, only a number will appear. This number will represent one or more error messages. To translate a number into an error message:

- 1 Note the number.
- 2 Select **Diagnostics/Vacuum Control** from the View menu.
- 3 Select **MS Error Codes** from the Status menu.
- 4 Type in the error number and press **Enter**.

The corresponding error message(s) will appear.

Some error messages are “latched”. These messages remain active in your data system even if the condition that caused the message has corrected itself. If the cause is removed, these messages can be removed by checking instrument status through the data system.

### **Difficulty in mass filter electronics**

- Pressure in the vacuum manifold is too high
- RFPA is not adjusted correctly
- Mass filter (quad) contacts are shorted or otherwise not working correctly
- Mass filter is not working correctly
- MSD electronics are not working correctly

### **Difficulty with the electron multiplier supply**

- Large peak such as the solvent peak eluted while the analyzer was on
- Pressure in the vacuum manifold is too high
- MSD electronics are not working correctly

### **Difficulty with the fan**

If a cooling fan fault occurs, the vacuum control electronics automatically shut off the high vacuum pump and the ion source and mass filter heaters. Therefore, the message: *The system is in vent state* may also appear. It is important to note that even though the high vacuum pump is off, the vacuum manifold may not actually be vented. See *The system is in vent state* in this section for precautions to take.

- One of the fans is disconnected
- One of the fans has failed
- MSD electronics are not working correctly

### **Difficulty with the HED supply**

- Large peak such as the solvent peak eluted while the analyzer was on
- Pressure in the vacuum manifold is too high
- Bad cable connection between the detector and the MSD electronics
- Detector is not working correctly
- MSD electronics are not working correctly

### **Difficulty with the high vacuum pump**

In an MSD equipped with a diffusion pump, this indicates the diffusion pump became too hot. In an MSD equipped with a turbomolecular pump, this indicates the pump failed to reach 50% of full speed in a preset time or experienced a fault.

You must switch the MSD off and back on to remove this error message. Be sure the diffusion pump has cooled or the turbo pump has slowed down before switching off the MSD. The message will reappear if the underlying problem has not been corrected.

#### ***Diffusion pump***

- Cooling fan for the high vacuum pump is not working
- Air intakes to the cooling fan are blocked
- Laboratory temperature is too high (generally above 35°C)
- High vacuum signal cable is disconnected or not working correctly
- Diffusion pump temperature sensor is not working correctly
- MSD electronics are not working correctly

#### Error messages

##### ***Turbomolecular pump***

- Large vacuum leak is preventing the turbo pump from reaching 50% of full speed
- Foreline pump is not working correctly
- Turbo pump is not working correctly
- Turbo pump controller is not working correctly
- MSD electronics are not working correctly

##### **Foreline pressure has exceeded 300 mTorr**

Only diffusion pump-equipped MSDs have a foreline pressure gauge.

- Excessive carrier gas flow (typically > 5 ml/min)
- Excessive solvent volume injected
- Large vacuum leak
- Collapsed or kinked foreline hose
- Foreline pump is not working correctly
- Foreline gauge is not working correctly

##### **Internal MS communication fault**

- MSD electronics are not working correctly

##### **Lens supply fault**

- Electrical short in the analyzer
- MSD electronics are not working correctly

##### **Log amplifier ADC error**

- MSD electronics are not working correctly

##### **No peaks found**

- Emission current was set to 0
- Electron multiplier voltage is too low
- Amu gain or offset is too high
- Calibration valve is empty

### **Temperature control disabled**

- One of the heater fuses has failed
- MSD electronics are not working correctly

### **Temperature control fault**

This indicates that something has gone wrong with the temperature control of either the ion source or mass filter (quad) heater. The cause can be further isolated by selecting **Status/MS Temp Ctlr Status** in the Diagnostics/Vacuum Control view. One of the following should be displayed as the cause:

- Source temperature sensor is open
- Source temperature sensor is shorted
- Mass filter (quad) temperature sensor is open
- Mass filter (quad) temperature sensor is shorted
- No heater voltage (heater fuse has probably failed)
- Heater voltage is too low
- Temperature zone has timed out (heater failed, bad heater wiring, or loose temperature sensor)
- Problem with the temperature control electronics

### **The high vacuum pump is not ready**

- Diffusion pump is on but has not had enough time (10 - 15 minutes) to reach its normal operating temperature
- Turbomolecular pump is on but has not had enough time (5 - 10 minutes) to reach 80% of its normal operating speed
- Level of fluid in the diffusion pump is too high
- Diffusion pump stack is not aligned correctly
- Turbomolecular pump is not working correctly
- MSD electronics are not working correctly

### **The system is in standby**

This message is triggered by a shutdown signal on the remote start cable. It is usually caused by a GC fault, an ALS fault, or a bad cable connection. Once the cause of the fault is corrected, selecting **MS ON** or checking MSD status should remove the message.

#### Error messages

##### **The system is in vent state**

Although the message says the system is in vent state, if the fault has just occurred the MSD may actually still be under vacuum and the diffusion pump may still be hot or the turbo pump may still be at high speed. Wait at least 30 minutes after seeing this message before you actually vent the MSD.

---

**CAUTION**

---

Venting the MSD too soon after this message appears can result in the backstreaming of a diffusion pump or damage to a turbomolecular pump.

- System was vented on purpose (no problem)
- Fan fault has turned off the high vacuum pump (power cycle the MSD to clear the fault)
- Fuse for the high vacuum pump has failed
- Diffusion pump heater cartridge has failed
- MSD electronics are not working correctly

##### **There is no emission current**

- Filament is not connected properly
- Filament has failed
- MSD electronics are not working correctly

##### **There is not enough signal to begin tune**

- Poor mass axis calibration
- Amu gain or offset is too high
- Calibration vial is empty or almost empty
- Excessive pressure in the vacuum manifold
- Air leak
- Electron multiplier voltage is too low
- Signal cable is not connected
- Electrical leads to the detector are not connected correctly
- Electrical leads to the ion source are not connected correctly
- Filament shorted to the source body

---

## Air leaks

Air leaks are a problem for any instrument that requires a vacuum to operate. Leaks are generally caused by vacuum seals that are damaged or not fastened correctly. Symptoms of leaks include:

- Higher than normal vacuum manifold pressure or foreline pressure
- Higher than normal background
- Peaks characteristic of air ( $m/z$  18, 28, 32, and 44 or  $m/z$  14 and 16)
- Poor sensitivity
- Low relative abundance of  $m/z$  502 (this varies with the tune program used)

Leaks can occur in either the GC or the MSD. The most likely point for an air leak is a seal you recently opened.

In the GC, most leaks occur in:

- Injection port septum
- Injection port column nut
- Broken or cracked capillary column

Leaks can occur in many more places in the MSD:

- GC/MSD interface column nut
- GC/MSD interface O-ring (where the interface attaches to the vacuum manifold)
- Side plate O-ring (all the way around)
- Front and rear end plate O-rings
- Triode gauge tube fitting
- Vent valve O-ring
- Calibration valve
- Diffusion pump KF seal
- Diffusion pump baffle adapter O-ring
- Turbomolecular pump O-ring

#### Contamination

---

## Contamination

Contamination is usually identified by excessive background in the mass spectra. It can come from the GC or from the MSD. The source of the contamination can sometimes be determined by identifying the contaminants. Some contaminants are much more likely to originate in the GC. Others are more likely to originate in the MSD.

Contamination originating in the GC typically comes from one of these sources:

- Column or septum bleed
- Dirty injection port
- Injection port liner
- Contaminated syringe
- Poor quality carrier gas
- Dirty carrier gas tubing
- Fingerprints (improper handling of clean parts)

Contamination originating in the MSD typically comes from one of the following sources:

- Air leak
- Cleaning solvents and materials
- Diffusion pump fluid
- Foreline pump oil
- Fingerprints (improper handling of clean parts)

The following table lists some of the more common contaminants, the ions characteristic of those contaminants, and the likely sources of those contaminants.

Table 3

Common contaminants		
Ions ( <i>m/z</i> )	Compound	Possible source
18, 28, 32, 44 or 14, 16	H <sub>2</sub> O, N <sub>2</sub> , O <sub>2</sub> , CO <sub>2</sub> or N, O	Residual air and water, air leaks, outgassing from Vespel ferrules
31, 51, 69, 100, 119, 131, 169, 181, 214, 219, 264, 376, 414, 426, 464, 502, 576, 614	PFTBA and related ions	PFTBA (tuning compound)
31	Methanol	Cleaning solvent
43, 58	Acetone	Cleaning solvent
78	Benzene	Cleaning solvent
91, 92	Toluene or xylene	Cleaning solvent
105, 106	Xylene	Cleaning solvent
151, 153	Trichloroethane	Cleaning solvent
69	Foreline pump oil or PFTBA	Foreline pump oil vapor or calibration valve leak
73, 147, 207, 221, 281, 295, 355, 429	Dimethylpolysiloxane	Septum bleed or methyl silicone column bleed
77, 94, 115, 141, 168, 170, 262, 354, 446	Diffusion pump fluid and related ions	Diffusion pump fluid
149	Plasticizer (phthalates)	Vacuum seals (O-rings) damaged by high temperatures, vinyl gloves
Peaks spaced 14 amu apart	Hydrocarbons	Fingerprints, foreline pump oil



Before starting, 94

Maintaining the vacuum system, 101

Maintaining the analyzer, 144

Maintaining the GC/MSD interface, 172

Maintaining the electronics, 177

---

## Maintaining the MSD

How to perform common maintenance procedures for the MSD. Many of these procedures are demonstrated on the HP MSD Reference Collection CD-ROM.

---

## Before starting

You can perform much of the maintenance required by your MSD. For your safety, read all of the information in this introduction before performing any maintenance tasks.

### ***Some parts of the MSD require regularly scheduled maintenance***

Common maintenance tasks are listed in Table 4. Performing these tasks when scheduled can reduce operating problems, prolong system life, and reduce overall operating costs.

Keep a record of system performance (tune reports) and maintenance operations performed. This makes it easier to identify variations from normal operation and to take corrective action.

Table 4

---

**Maintenance schedule**

---

Task	Every week	Every 6 months	Every year	As needed
Tune the MSD				✓
Check the foreline pump oil level	✓			
Check the calibration vial		✓		
Replace the foreline pump oil <sup>1</sup>		✓		
Check the diffusion pump fluid			✓	
Clean the ion source				✓
Check the carrier gas trap(s) on the GC				✓
Replace the worn out parts				✓
Lubricate sideplate or vent valve O-rings <sup>2</sup>				✓

1 Every 3 months for CI MSDs using ammonia reagent gas.

2 Vacuum seals other than the side plate O-ring and vent valve O-ring do not need to be lubricated. Lubricating other seals can interfere with their correct function.

***Maintenance requires the proper tools, spare parts, and supplies***

Some of the required tools, spare parts, and supplies are included in the MSD shipping kit or MSD tool kit. You must supply others yourself. Each maintenance procedure includes a list of the materials required for that procedure. Tables 5 and 6 summarize these.

**Table 5**

<b>Tools</b>	
<b>Description</b>	<b>HP part number</b>
Ball driver	
1.5-mm	8710-1570
2.0-mm	8710-1804
2.5-mm	8710-1681
Funnel	-----
Hex nut driver, 5.5-mm	8710-1220
Pliers, long-nose (1.5-inch nose)	8710-1094
Screwdriver	
flat-blade, large	8730-0002
TORX, T-10	8710-1623
TORX, T-15	8710-1622
TORX, T-20	8710-1615
Tweezers, non-magnetic	8710-0907
Wrench, open-end	
1/4-inch × 5/16-inch	8710-0510
10-mm	8710-2353
Wrist strap, anti-static	
small	9300-0969
medium	9300-1257
large	9300-0970

Table 6

<b>Spare parts and supplies</b>	
<b>Description</b>	<b>HP part number</b>
Abrasive paper	5061-5896
Alumina abrasive powder	8660-0791
Aluminum foil, clean	————
Beakers, glass, 50 ml and 500 ml	————
Cloths, clean, lint-free (quantity 20)	05980-60051
Container, for catching old foreline pump oil, ≈ 500 ml	————
Cotton swabs (quantity 100)	5080-5400
Diffusion pump fluid	6040-0809
Electron multiplier horn	05971-80103
Filament assembly	05972-80053
Foreline exhaust oil trap	3150-0761
Foreline pump oil, 1 liter	6040-0834
Gloves	
chemical-resistant (resistant to oils and solvents)	————
clean, lint-free (large)	8650-0030
clean, lint-free (small)	8650-0029
Grease, Apiezon L, high vacuum	6040-0289
Heater/sensor assemblies	
GC/MSD interface	05972-60106
ion source	G1099-60177
mass filter	G1099-60172
Octafluoronaphthalene, 1 pg/ul	8500-5441
Perfluorotributylamine (PFTBA), certified (1 gram)	8500-0656
PFTBA sample kit	05971-60571
Solvents, reagent-grade — acetone, methanol, methylene chloride	————
Triode gauge tube	0960-0897
Ultrasonic bath	————

***Many parts of the MSD carry high voltages that are potentially dangerous***

Whenever the MSD is plugged in, even if the power switch is off, potentially dangerous voltage (120 V ac or 200/240 V ac) exists on:

- The wiring and fuses between where the power cord enters the instrument and the power switch

When the power switch is on, potentially dangerous voltages exist on:

- Electronic circuit boards
- Toroidal transformer
- Turbomolecular pump controller
- Wires and cables between these boards
- Wires and cables between these boards and the connectors on the back panel of the MSD
- Some connectors on the back panel (for example, the foreline power receptacle)

Normally, all of these parts are shielded by safety covers. As long as the safety covers are in place, it should be difficult to accidentally make contact with dangerous voltages.

---

**W A R N I N G**

---

**Perform no maintenance with the MSD turned on or plugged into its power source unless you are instructed to by one of the procedures in this chapter.**

One or two procedures in this chapter require access to the inside of the MSD while the power switch is on. Do not remove any of the electronics safety covers in any of these procedures. To reduce the risk of electric shock, follow the procedures carefully.

If your instrument is equipped with the optional gauge controller, potentially dangerous voltage also exists where the cable from the gauge controller connects to the triode gauge tube. Turn off the gauge controller if you are going to be working near the triode gauge tube.

***Many parts are hot enough to be dangerous***

Many parts in the MSD operate at, or reach, temperatures high enough to cause serious burns. These parts include, but are not limited to:

- GC/MSD interface
- Analyzer parts
- Vacuum pumps

---

**W A R N I N G**

---

**Never touch these parts while your MSD is on. After the MSD is turned off, give these parts enough time to cool before handling them.**

---

**W A R N I N G**

---

**The GC/MSD interface heater is powered by the Thermal Aux #2 heated zone on the GC. The interface heater can be on, and at a dangerously high temperature, even though the MSD is off. The GC/MSD interface is well insulated. Even after it is turned off, it cools very slowly.**

The GC injection ports and GC oven also operate at very high temperatures. Use the same caution around these parts. See the documentation supplied with your GC for more information.

***Chemical residue is another potential danger***

Only a small portion of your sample is ionized by the ion source. The majority of any sample passes through the ion source without being ionized. It is pumped away by the vacuum system. As a result, the exhaust from the foreline pump will contain traces of the carrier gas and your samples. It will also contain tiny droplets of foreline pump oil.

An oil trap is supplied with the foreline pump. This trap stops **only** pump oil droplets. It **does not** trap any other chemicals. If you are using toxic solvents or analyzing toxic chemicals, do not use the oil trap. Instead, install a hose to take the exhaust from the foreline pump outdoors or into a fume hood vented to the outdoors. Be sure to comply with your local air quality regulations.

---

**W A R N I N G**

---

**The oil trap stops only foreline pump oil. It does not trap or filter out toxic chemicals. If you are using toxic solvents or analyzing toxic chemicals, remove the oil trap. Do not use the trap if you have a CI MSD. Install a hose to take the foreline pump exhaust outside or to a fume hood.**

The fluids in the diffusion pump and foreline pump also collect traces of the samples being analyzed. All used pump fluid should be considered hazardous and handled accordingly. Dispose of used fluid correctly, as specified by your local regulations.

---

**W A R N I N G**

---

**When replacing pump fluid, use appropriate chemical-resistant gloves and safety glasses. Avoid all contact with the fluid.**

***Electrostatic discharge is a threat to the MSD electronics during maintenance***

All of the printed circuit boards in the MSD contain components that can be damaged by electrostatic discharge (ESD). Do not handle or touch these boards unless absolutely necessary. In addition, wires, contacts, and cables can conduct ESD to the electronics boards to which they are connected. This is especially true of the mass filter (quadrupole) contact wires which can carry ESD to sensitive components on the side board. ESD damage may not cause immediate failure but it will gradually degrade the performance and stability of your MSD.

When you work on or near printed circuit boards, or when you work on components with wires, contacts, or cables connected to printed circuit boards, always use a grounded anti-static wrist strap and take other anti-static precautions. The wrist strap should be connected to a known good Earth ground. If that is not possible, it should be connected to a conductive (metal) part of the assembly being worked on, but **not** to electronic components, exposed wires or traces, or pins on connectors.

Take extra precautions, such as a grounded, anti-static mat, if you must work on components or assemblies that have been removed from the MSD. This includes the analyzer.

---

**CAUTION**

---

In order to be effective, an anti-static wrist strap must fit snugly (not tight). A loose strap provides little or no protection.

---

**CAUTION**

---

Anti-static precautions are not 100% effective. Handle electronic circuit boards as little as possible, and then only by the edges. Never touch components, exposed traces, or pins on connectors and cables.

## Maintaining the vacuum system

### ***The vacuum system requires some periodic maintenance***

As listed earlier in Table 4, some maintenance tasks for the vacuum system must be performed periodically. These include:

- Checking the foreline pump fluid (every week)
- Checking the calibration vial (every 6 months)
- Replacing the foreline pump oil (every 6 months; every 3 months for CI MSDs using ammonia reagent gas)
- Checking the diffusion pump fluid (once a year)

Failure to perform these tasks as scheduled can result in decreased instrument performance. It can also result in damage to your instrument.

### ***Other procedures should be performed as needed***

Tasks such as replacing a foreline vacuum gauge or triode gauge tube should be performed only when needed. See Chapter 3, *Troubleshooting the MSD*, on page 65 and see the online help in the MSD ChemStation software for symptoms that indicate this type of maintenance is required.

### ***More information is available***

If you need more information about the locations or functions of vacuum system components, refer to Chapter 5, *Vacuum System*, on page 183.

Most of the procedures in this chapter are illustrated with video clips in the HP 5973 MSD Reference Collection CD-ROM.

**To check and add foreline pump oil**

---

## To check and add foreline pump oil

*Materials needed:* Foreline pump oil (6040-0834)  
Funnel

A slow loss of oil is normal for the foreline pump. Therefore, it is especially important to check the oil level regularly.

**1 Examine the oil level window.**

The oil level should be above the lower line. The foreline pump oil should be almost clear. If the oil level is near or below the lower line, follow the steps 2 – 6 to add foreline pump oil.

---

**W A R N I N G**

---

**Never add oil while the foreline pump is on.**

If your MSD is nearing its scheduled time for replacement of the foreline pump oil, replace the oil instead of adding oil. If the oil is dark or cloudy, replace it. See page 104 for instructions about replacing the foreline pump oil.

**2 Vent the MSD (page 52).**

**3 Remove the fill cap.**

**4 Add pump fluid until the oil level in the window is near, but not above, the upper line.**

**5 Reinstall the fill cap.**

**6 Pump down the MSD (page 58).**

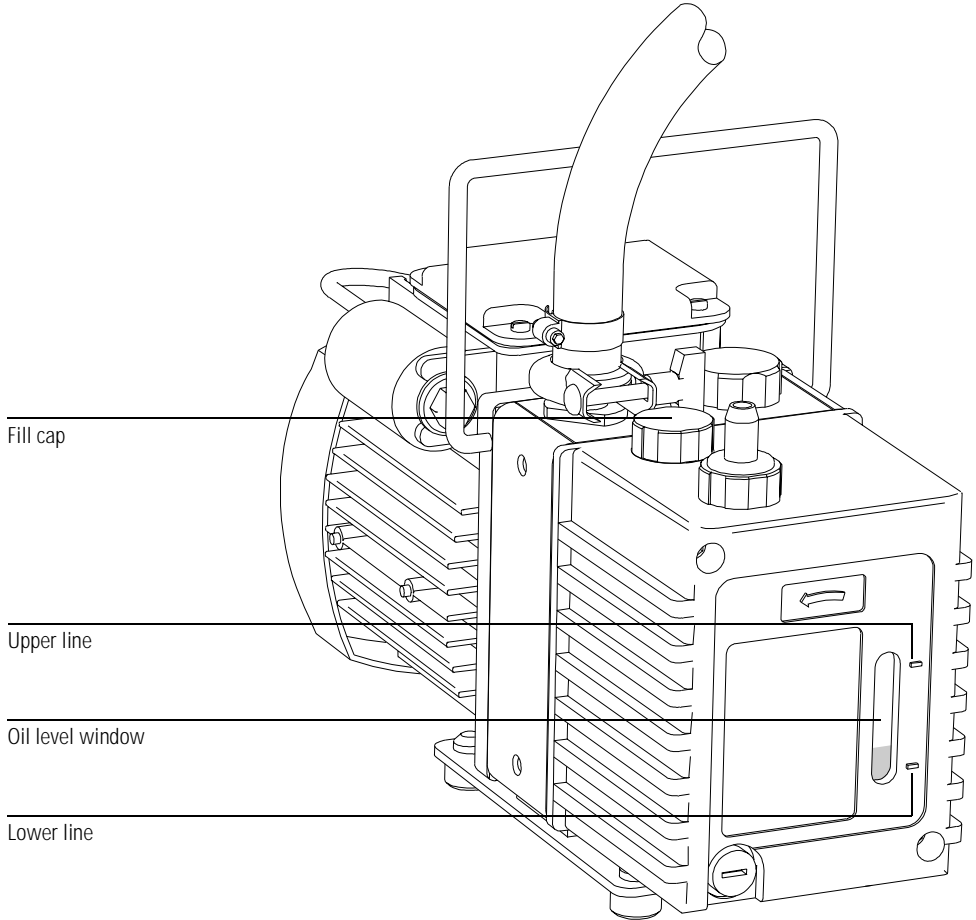

**To drain the foreline pump**

---

## To drain the foreline pump

*Materials needed:*

Book or other solid object approximately 5 cm thick  
Container for catching old pump oil, 500 ml  
Gloves, oil- and solvent-resistant  
Screwdriver, flat-blade, large (8730-0002)

- 1 Vent the MSD (page 52).**
- 2 If necessary, slide the foreline pump out from under the vacuum manifold.**  
The foreline pump may be located on the floor, on the lab bench next to or behind the MSD, or under the vacuum manifold at the back of the MSD.

---

**W A R N I N G**

---

**The foreline pump may be hot.**

- 3 Place a book or other object under the pump motor to tilt it up slightly.**
- 4 Remove the fill cap.**
- 5 Place a container under the drain plug.**
- 6 Remove the drain plug.**  
Allow the pump oil to drain out. The oil drains faster if it is still warm.

---

**W A R N I N G**

---

**The old pump oil may contain toxic chemicals. Treat it as hazardous waste.**

- 7 Refill the foreline pump (page 106).**

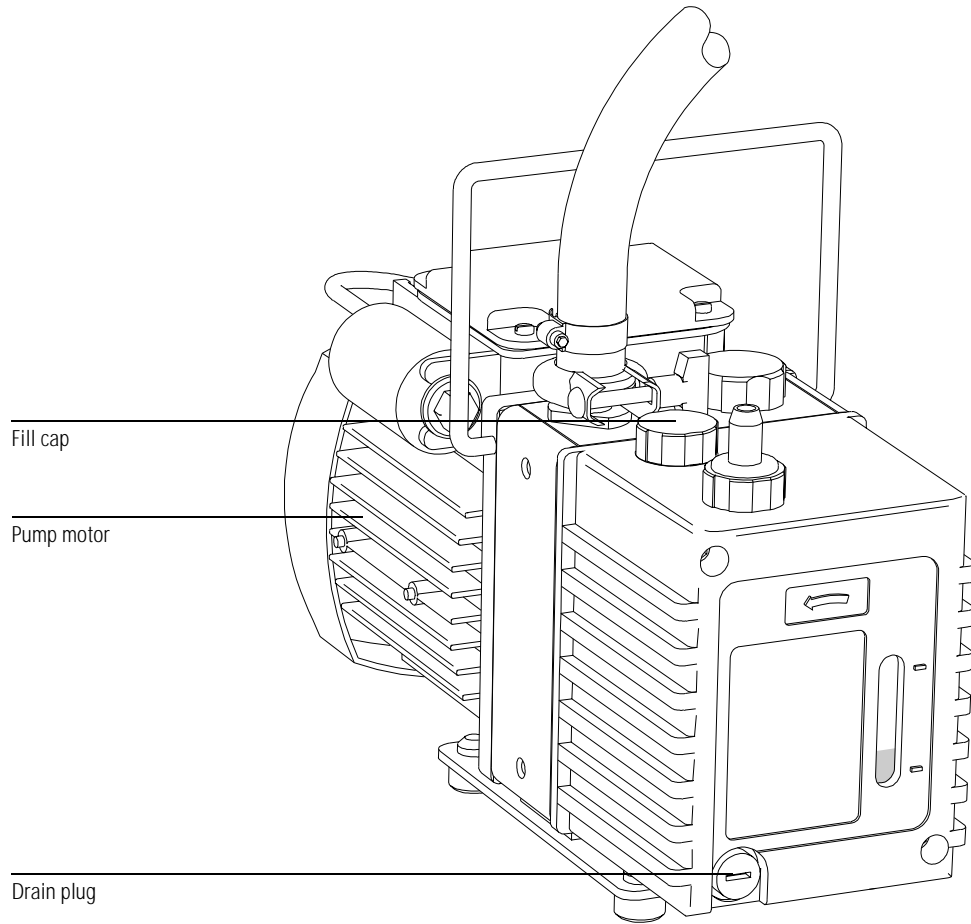

## To refill the foreline pump

*Materials needed:* Foreline pump oil (6040-0834) – approximately 0.28 liters required  
Funnel  
Gloves, oil- and solvent-resistant  
Screwdriver, flat-blade, large (8730-0002)

- 1 Drain the foreline pump (page 104).**
- 2 Reinstall the drain plug.**
- 3 Remove the propping object from under the pump motor.**
- 4 Add foreline pump oil until the oil level in the window is near, but not above, the upper line.**

The foreline pump requires approximately 0.28 liters of oil.
- 5 Wait a few minutes for the oil to settle.**

If the oil level drops, add oil to bring the oil level to near the upper line.
- 6 Reinstall the fill cap.**
- 7 If necessary, slide the foreline pump back under the vacuum manifold.**

The foreline pump may be located on the floor, on the lab bench next to or behind the MSD, or under the vacuum manifold at the back of the MSD.
- 8 Pump down the MSD (page 58).**

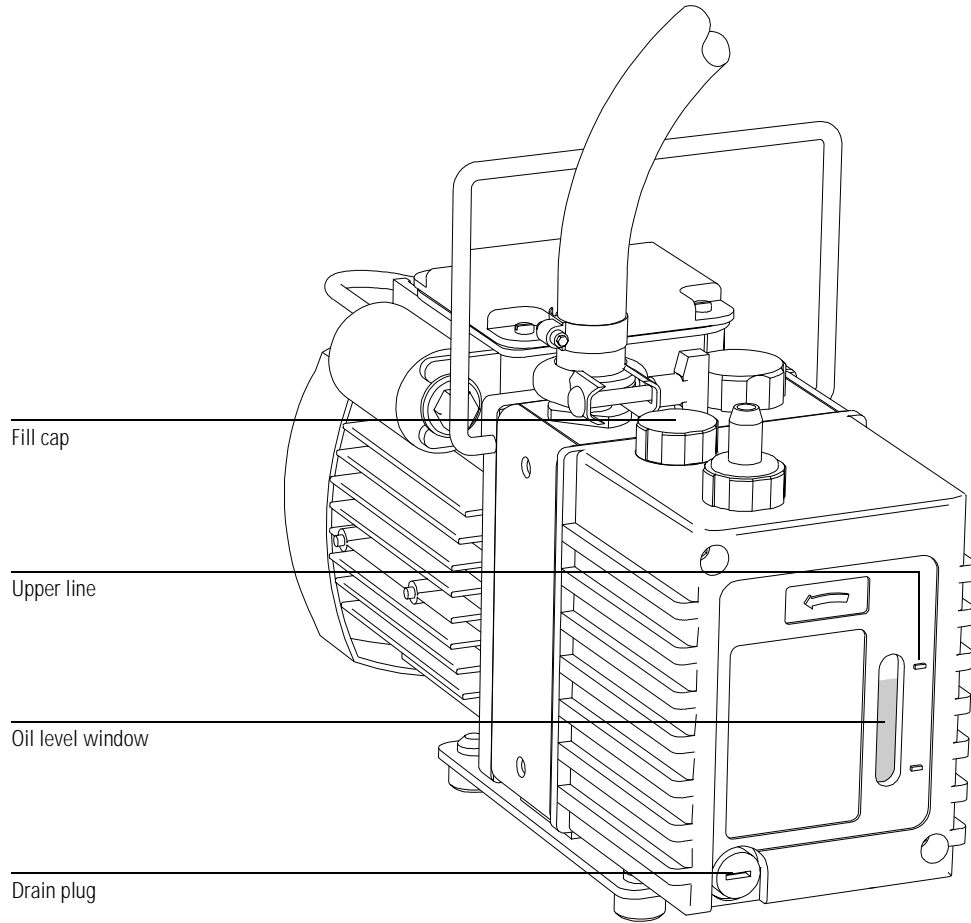

To replace the oil trap

---

## To replace the oil trap

*Materials needed:*

Gloves, oil- and solvent-resistant  
Oil trap, foreline exhaust (3150-0761)

If you are using the supplied oil trap on the exhaust port of the foreline pump, you should replace the trap whenever the white filter element turns brown. The trap can be replaced without turning off the MSD.

---

**W A R N I N G**

**Do not breathe the pump exhaust; it may contain pump oil vapor. Do not replace the trap while samples are being analyzed.**

---

**W A R N I N G**

**The trap stops only foreline pump oil. It does not trap or filter out toxic chemicals. If you are using toxic solvents or analyzing toxic chemicals, remove the oil trap. Do not use the trap with a CI MSD. Install a hose to take the foreline pump exhaust outside or to a fume hood.**

- 1 Remove the clamp that holds the oil trap to the trap adapter.**

---

**W A R N I N G**

**Do not touch the foreline pump; it may be hot.**

- 2 Remove the oil trap.**  
Make sure the O-ring assembly stays on the adapter.

- 3 Install a new oil trap.**

- 4 Reinstall the clamp that holds the oil trap to the trap adapter.**

---

**W A R N I N G**

**The oil trap will contain traces of oil, solvents, and analytes. Treat it as hazardous. Dispose of the oil trap in accordance with local environmental and safety regulations.**

---

**C A U T I O N**

If the trap has turned brown quickly, the MSD probably has a large air leak. Find and repair the air leak before installing a new trap. See page 89.

To replace the oil trap

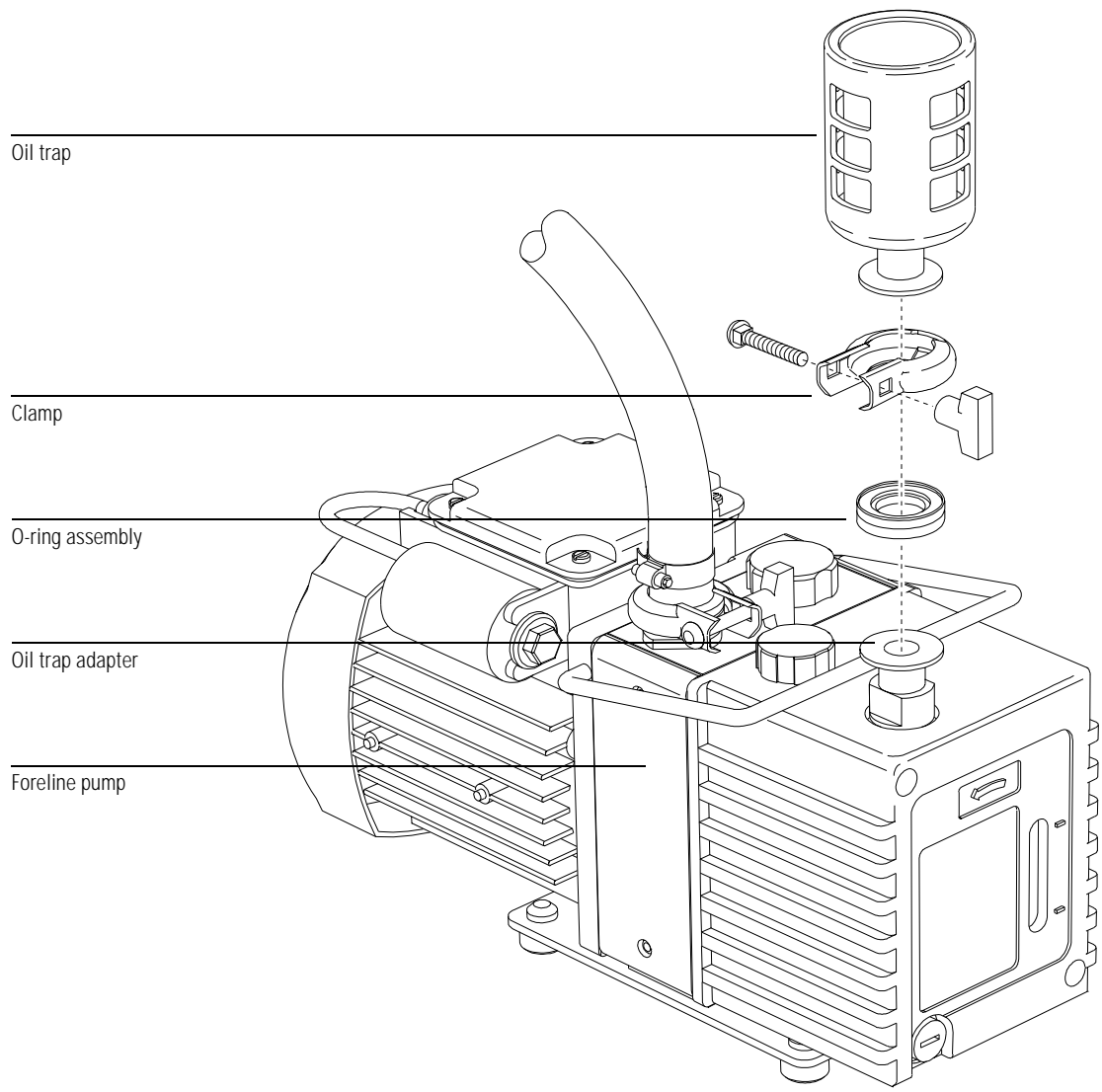

Oil trap

Clamp

O-ring assembly

Oil trap adapter

Foreline pump

**To check the diffusion pump fluid**

---

## To check the diffusion pump fluid

*Materials needed:* Screwdriver, TORX T-15 (8710-1622)

**1 Remove the upper and lower MSD covers (page 50).**

---

**W A R N I N G**

---

**Do not remove any other covers. Removing other covers may expose hazardous voltages.**

**2 Check the diffusion pump fluid level.**

The diffusion pump fluid level can be seen through the window below the fan at the front of the MSD. The diffusion pump fluid level should be between the top and bottom of one of the **FULL** ranges. There are two sets of marks. Use the **HOT** marks if the diffusion pump is on and is at its normal operating temperature. Use the **COLD** marks if the pump is off and has had time to cool. If the fluid level is below the bottom of the appropriate range, replace the diffusion pump fluid. Do not just add fluid.

The pump fluid should be clear or almost clear. Dark or cloudy pump fluid indicates an air leak or excessive heat. If the pump fluid appears dark or cloudy, replace it. Then, check for an air leak.

The diffusion pump fluid does not need to be replaced at regular intervals. A low pump fluid level or dark or cloudy pump fluid are the only reasons to replace the diffusion pump fluid.

---

**W A R N I N G**

---

**Keep your hair away from the cooling fan if the MSD is turned on.**

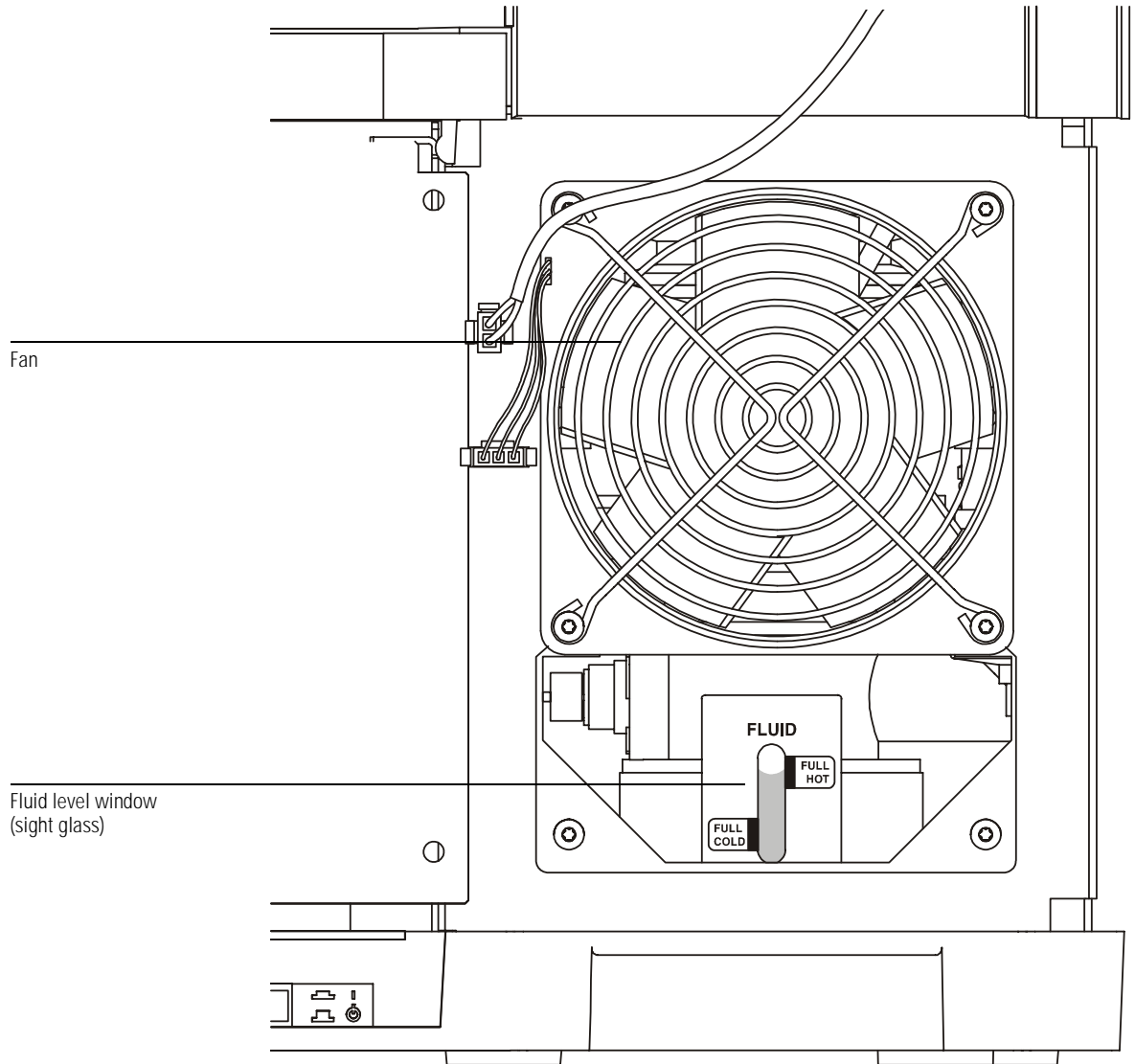

## To separate the MSD from the GC

*Materials needed:* Wrench, open-end, 1/4-inch × 5/16-inch (8710-0510)

- 1 Vent the MSD (page 52).**
- 2 Turn off the GC.**
- 3 Remove the capillary column from the GC/MSD interface.**

---

### **W A R N I N G**

---

**Make sure the GC/MSD interface and GC oven have cooled before you remove the column.**

- 4 If necessary, slide the foreline pump out from under the vacuum manifold.**  
The foreline pump may be located on the floor, on the lab bench next to or behind the MSD, or under the vacuum manifold at the back of the MSD.
- 5 Move the MSD away from the GC until you have access to the GC/MSD interface cable.**
- 6 Disconnect the GC/MSD interface cable.**  
Disconnecting the cable with the GC on can cause a fault condition.
- 7 Continue to move the MSD until you have access to the part requiring maintenance.**

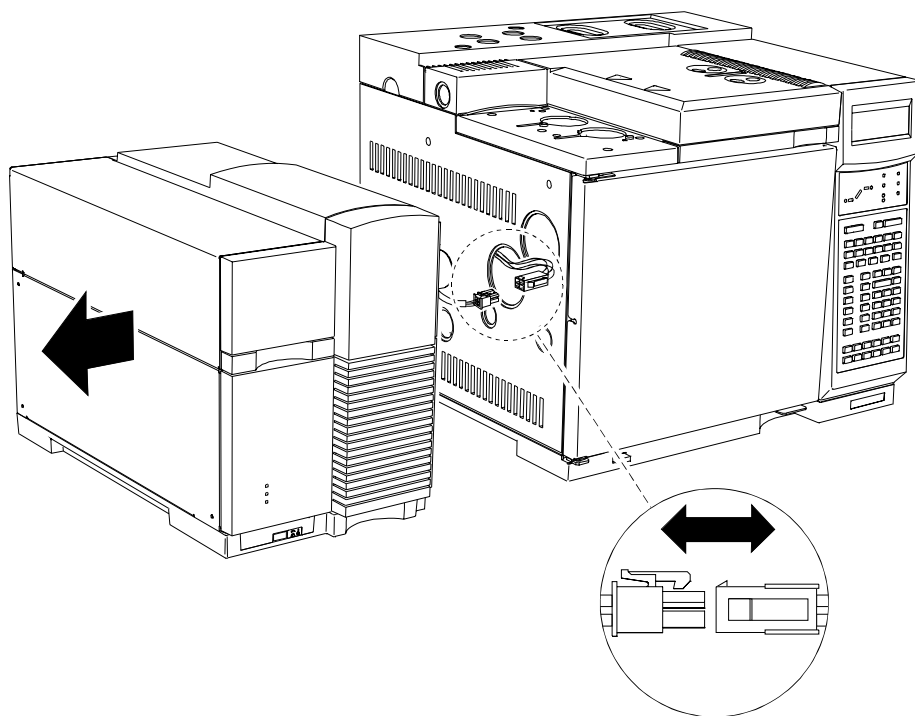

## To remove the diffusion pump

*Materials needed:* Aluminum foil, clean  
Gloves, oil-resistant

- 1 Vent the MSD (page 52).**
- 2 Separate the MSD from the GC (page 112).**

---

### W A R N I N G

---

**The diffusion pump operates at very high temperatures. Make sure it has cooled before handling it.**

- 3 Disconnect the foreline gauge assembly from the diffusion pump outlet.**  
The foreline gauge cable can be disconnected or can remain connected to the foreline gauge. Place the O-ring assembly on clean aluminum foil.
- 4 Disconnect the diffusion pump temperature sensor wires from the wiring harness.**  
These are on the side of the diffusion pump not shown in the illustration.
- 5 Disconnect high vacuum power (HIVAC POWER) cable from the back panel of the MSD.**  
This is the thick black cable that emerges near the bottom of the pump.
- 6 Support the diffusion pump with one hand.**
- 7 Remove the KF50 clamp.**
- 8 Lower the diffusion pump.**
- 9 Remove the O-ring assembly from the top of the diffusion pump.**  
The O-ring will have diffusion pump fluid on it and will be very sticky. Place the O-ring on clean aluminum foil to avoid contaminating your lab bench and to avoid having the O-ring pick up dust and dirt.

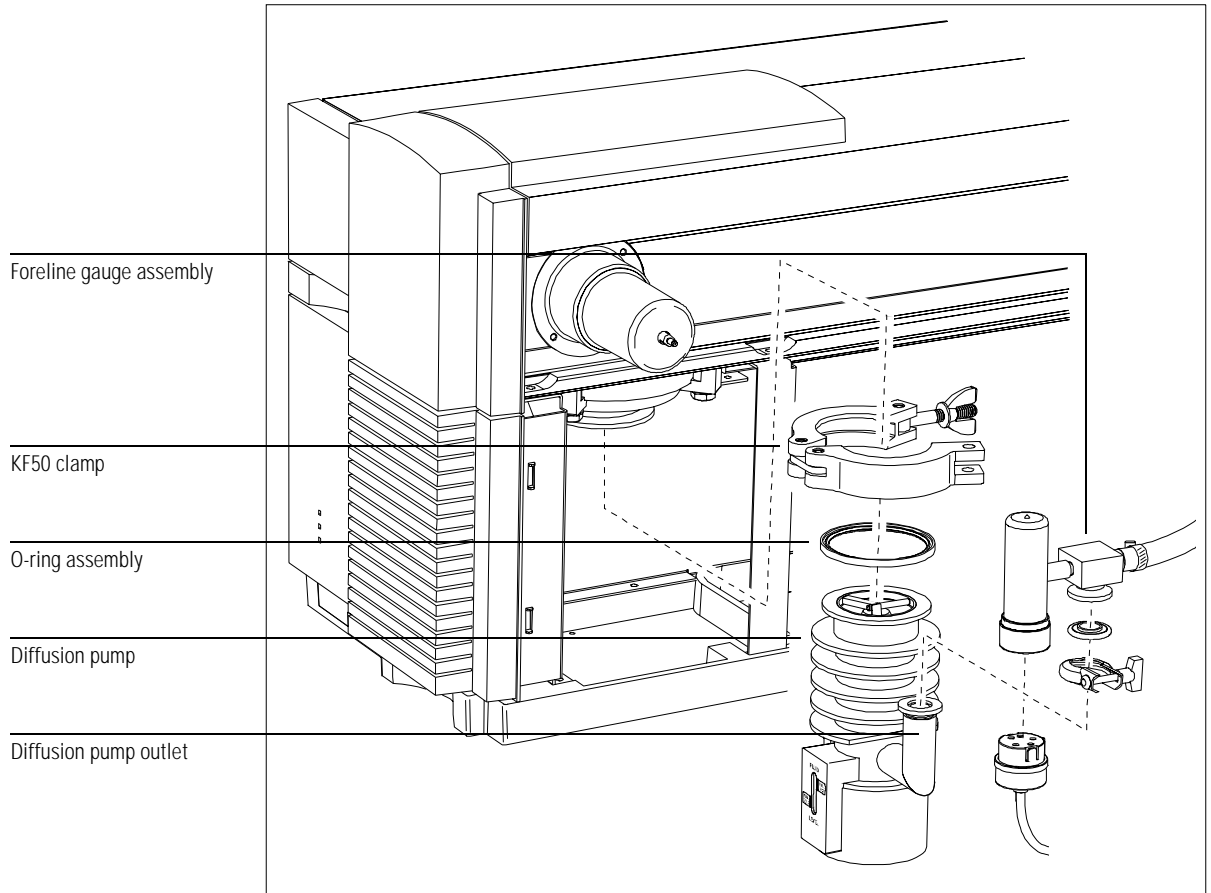

**10 Remove the diffusion pump through the side of the MSD.**

You may have to tilt the pump slightly to remove it. Do not tilt the pump past 45° if the pump is warm.

## To replace the diffusion pump fluid

*Materials needed:*

Aluminum foil, clean  
Cloths, clean, lint-free (05980-60051)  
Container for old diffusion pump fluid  
Diffusion pump fluid, 18.5 ml (6040-0809) – 2 required  
Gloves  
    oil- and solvent-resistant  
    thermally insulated

- 1 Remove the diffusion pump from the MSD (page 114).**  
Make sure you remove the O-ring assembly from the top of the diffusion pump.
- 2 Cover the top of the diffusion pump with aluminum foil.**
- 3 Heat the diffusion pump at 60°C for 15 minutes in your GC oven.**

---

**W A R N I N G**

**The pump and pump fluid will be hot. Wear protective gloves when you remove the pump from the oven.**

- 4 Pour the old diffusion pump fluid out the top of the pump.**

Even after heating, the pump fluid pours very slowly.

---

**W A R N I N G**

**Treat the old pump fluid as hazardous. It may contain traces of toxic chemicals.**

*Charred or blackened  
pump fluid*

If the diffusion pump has been heated with insufficient pump fluid (or with a large air leak in the MSD), the remaining pump fluid may be severely blackened. Blackened pump fluid may also be baked onto the internal parts (stack) of the pump. If so, you may have to remove the diffusion pump stack and clean its parts, and the interior of the pump, with methylene chloride. Be very careful when reinstalling the stack. Misalignment of stack components can seriously reduce diffusion pump performance.

---

**W A R N I N G**

**Methylene chloride is a hazardous solvent. Work in a fume hood and take all appropriate precautions.**

---

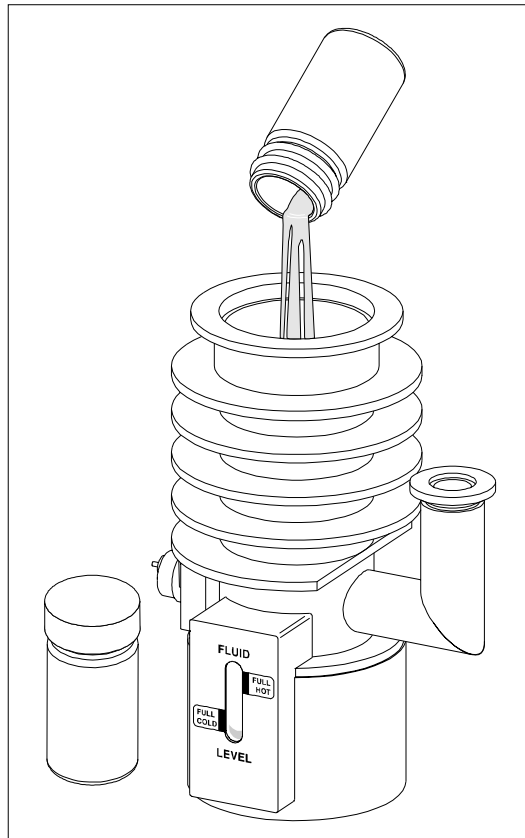

**5 Wipe clean the diffusion pump flange on the vacuum manifold.**

Follow the instructions on the bottle for pre-heating the diffusion pump fluid.

**6 Pour new diffusion pump fluid into diffusion pump until the fluid level is within the FULL COLD range.**

It will require approximately 1.5 to 2 containers (18.5 ml each) of diffusion pump fluid. Watch the sight glass while pouring. Do not overfill.

**7 Reinstall the diffusion pump (page 118).**

## To reinstall the diffusion pump

*Materials needed:*

Gloves, oil-resistant

Vacuum cleaner, non-ESD generating (HP 92175V or equivalent)

This procedure works best with two people, one to hold the pump and one to install the clamp.

**1 Vacuum the fan that cools the diffusion pump.**

Keeping the fan clean helps ensure maximum cooling. This is one of the few times you will have convenient access to the pump side of the fan.

**2 Slide the diffusion pump into the MSD.**

You may have to tilt the pump slightly to get it into the MSD. tilt it past 45°.

**3 Install the O-ring assembly on the diffusion pump.**

**4 Lift the diffusion pump into its normal position.**

**5 Install the KF50 clamp.**

**6 Reconnect the diffusion pump temperature sensor wires to the wiring harness.**

**7 Reconnect the high vacuum power cable to the HIVAC POWER connector on the back panel of the MSD.**

This is the thick black cable that emerges near the bottom of the pump.

**8 Reconnect the foreline gauge fitting to the outlet of the diffusion pump.**

If you disconnected the foreline gauge cable, reconnect it to the foreline gauge.

**9 Move the MSD back to its normal position (page 120).**

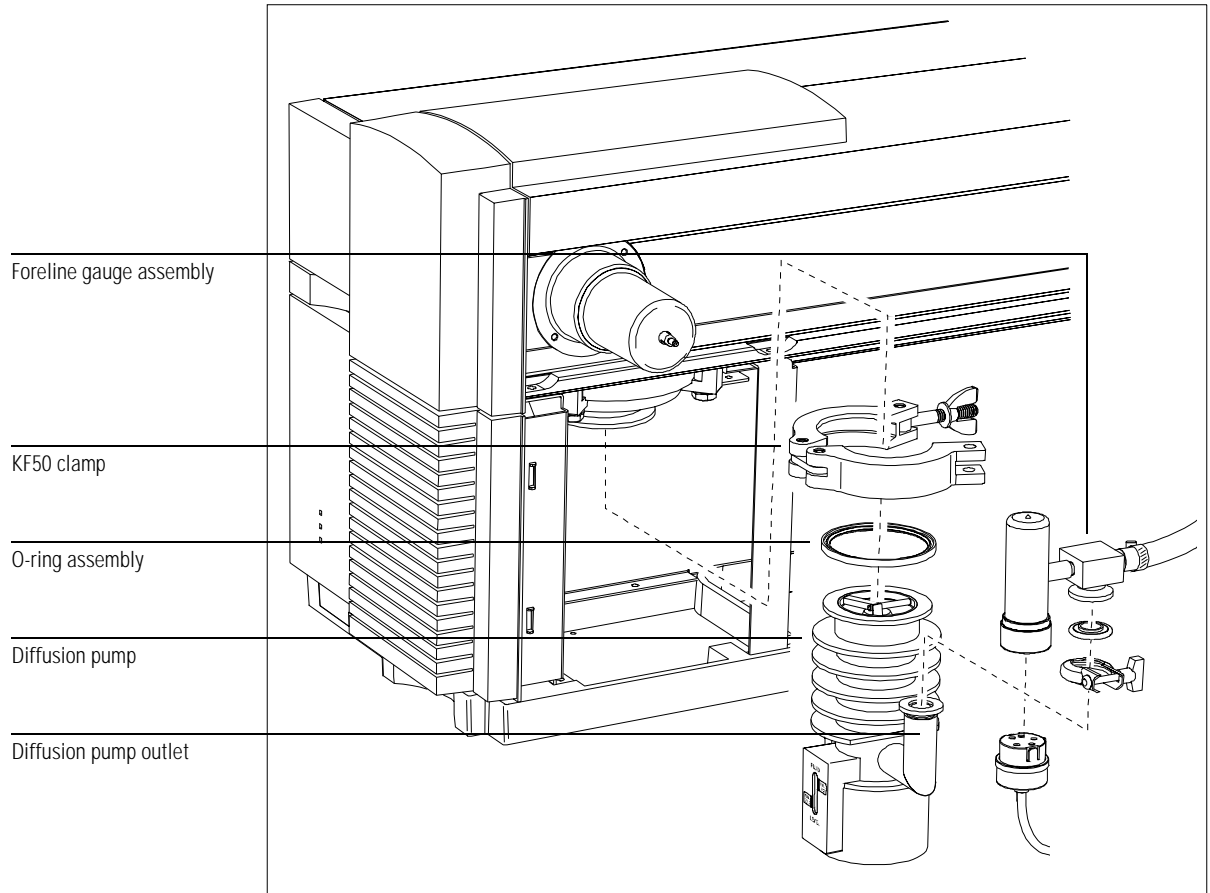

## To reconnect the MSD to the GC

*Materials needed:* Wrench, open-end, 1/4-inch × 5/16-inch (8710-0510)

**1 Position the MSD so the end of the GC/MSD interface is a few inches from the GC.**

**2 Reconnect the GC/MSD interface cable.**

**3 Slide the MSD to its regular position next to the GC.**

Be careful not to damage the GC/MSD interface as it passes into the GC. Make sure the end of the GC/MSD interface extends into the GC oven.

**4 If necessary, slide the foreline pump back under the vacuum manifold.**

The foreline pump may be located on the floor, on the lab bench next to or behind the MSD, or under the vacuum manifold at the back of the MSD.

**5 Reinstall the capillary column (page 28).**

**6 Pump down the MSD (page 58).**

**7 Turn on the GC.**

Re-establish appropriate temperature setpoints for the GC/MSD interface and GC oven.

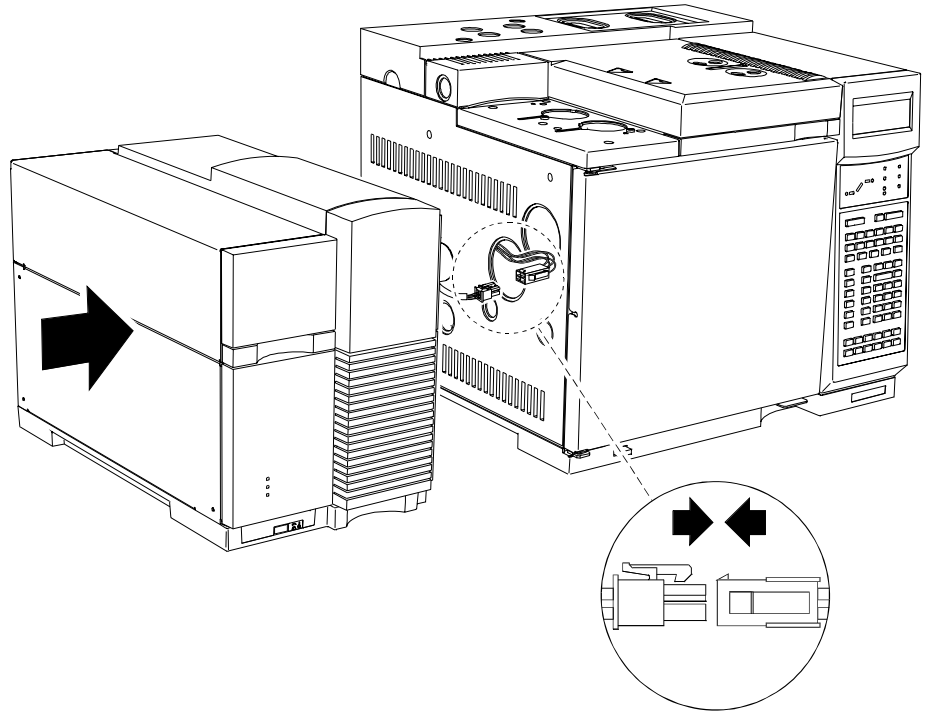

## To remove the calibration vial

*Materials needed:* None

**1 Stop any tuning or data acquisition.**

**2 Turn off the analyzer.**

There are several ways to turn off the analyzer:

- In the Diagnostics/Vacuum Control view, select **MS OFF** from the Diagnostics menu.
- In the Instrument Control view in the Edit Parameters dialog box, select **MS OFF** from the Execute menu.
- In the Manual Tune view, select **MS OFF** from the Execute menu.
- Type **MSOFF** on the command line and press **Enter**.
- Verify that **only** the power LED is lit on the front of the MSD.

**3 If your MSD is equipped with a gauge controller, switch off the triode gauge and the gauge controller.**

**4 Remove the upper MSD cover (page 50).**

**5 Loosen the calibration vial collar by turning it counterclockwise.**

Counterclockwise as viewed from the bottom (vial side) of the collar. Do not remove the collar.

**6 Pull the calibration vial out.**

You may feel some resistance due to residual vacuum.

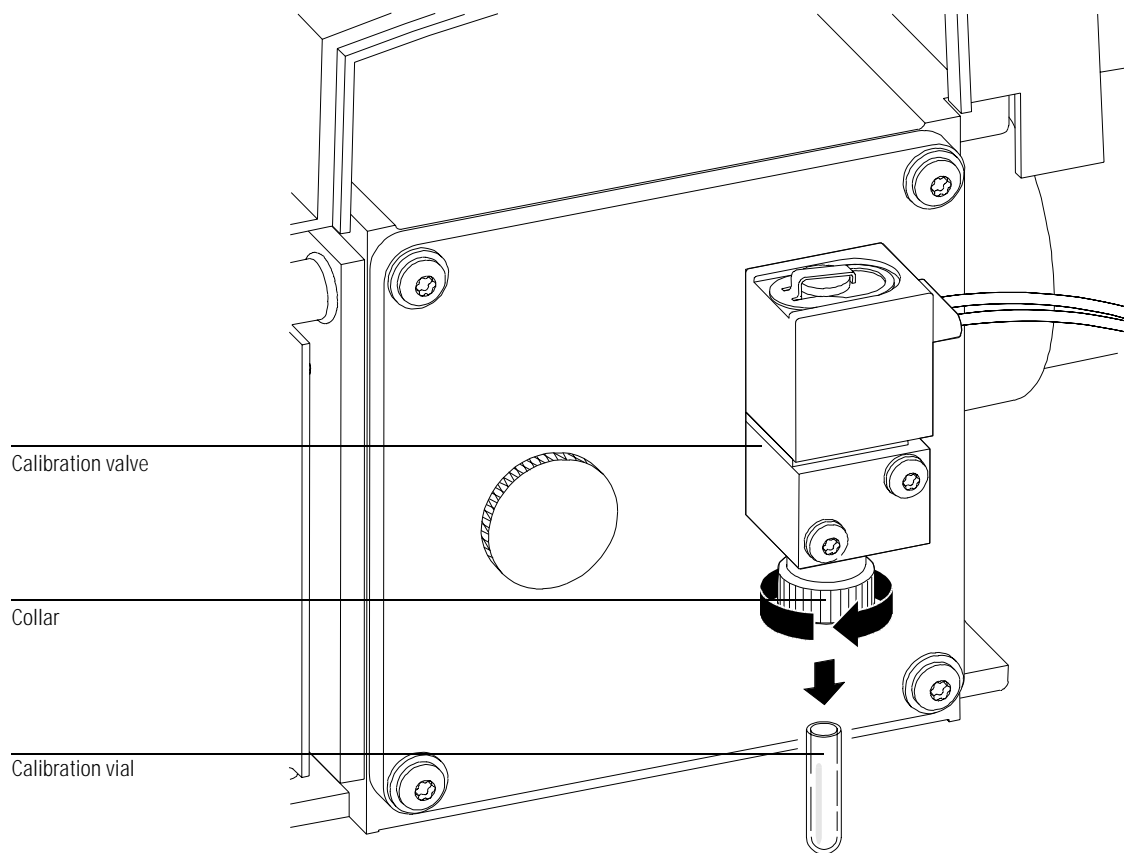

## To refill and reinstall the calibration vial

*Materials needed:* PFTBA (05971-60571) or other tuning compound

- 1 Remove the calibration vial (page 122).**
- 2 Pour PFTBA into the vial.**  
Leave 6-mm of the vial unfilled.
- 3 Push the calibration vial into the valve as far as possible.**
- 4 Withdraw the vial 1 mm.**  
This prevents damage when you tighten the collar.
- 5 Turn the collar clockwise to tighten it.**  
Clockwise as viewed from the bottom (vial side) of the collar. The collar should be snug but not overly tight. Do *not* use a tool to tighten the collar. It does not require that much force.
- 6 Reinstall the upper MSD cover.**
- 7 Select Purge Cal Valve from the Vacuum menu in the Diagnostics/Vacuum Control view.**

---

### CAUTION

---

Failure to purge the calibration valve will result in damage to the filaments and detector.

To refill and reinstall the calibration vial

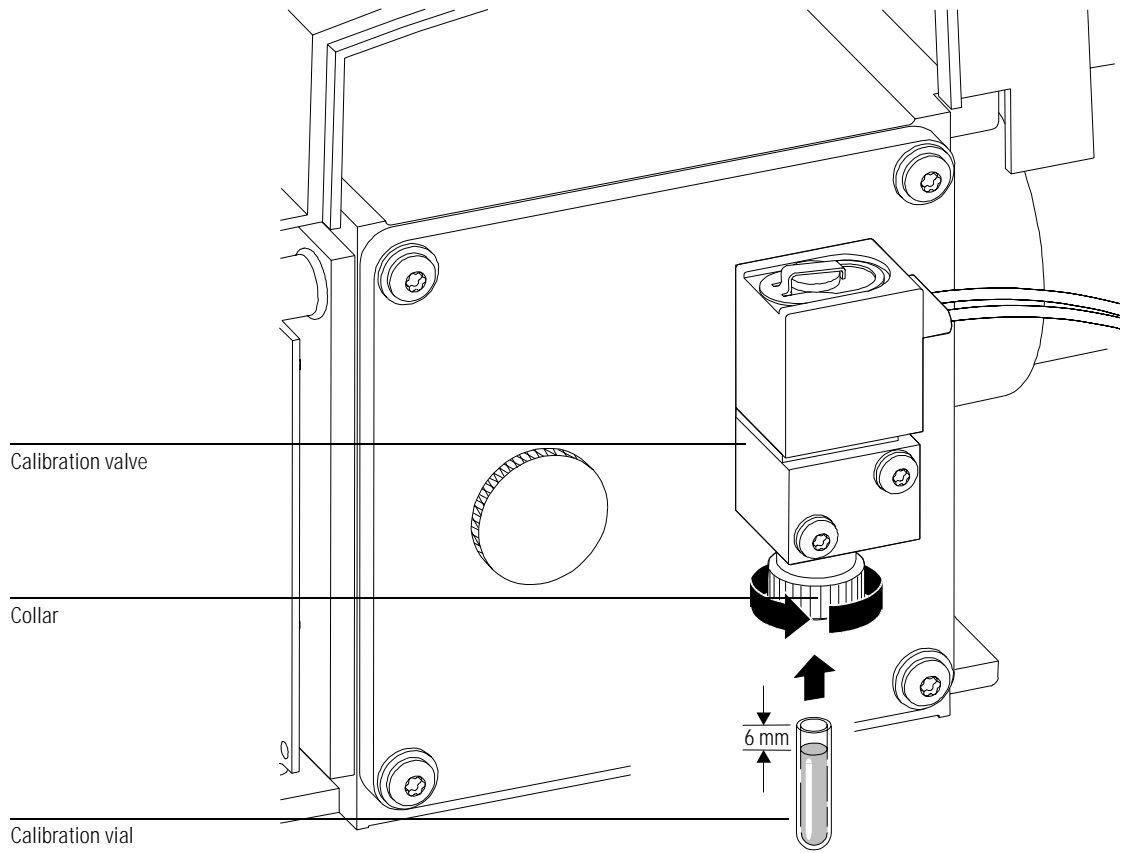

To remove the foreline gauge

---

## To remove the foreline gauge

*Materials needed:* Screwdriver, flat-blade, large (8730-0002)

- 1 Vent the MSD (page 52).
- 2 Separate the MSD from the GC (page 112).

---

**W A R N I N G**

---

The foreline pump and diffusion pump may still be hot.

- 3 Unplug the foreline gauge cable from the foreline gauge.
- 4 Disconnect the foreline gauge assembly from the diffusion pump outlet.
- 5 Loosen the hose clamp.
- 6 Pull the foreline gauge assembly out of the foreline hose.

---

**C A U T I O N**

---

Be sure the MSD is vented to atmosphere before breaking the seal at the foreline gauge. *Never* vent the MSD at the pump end; use the vent valve.

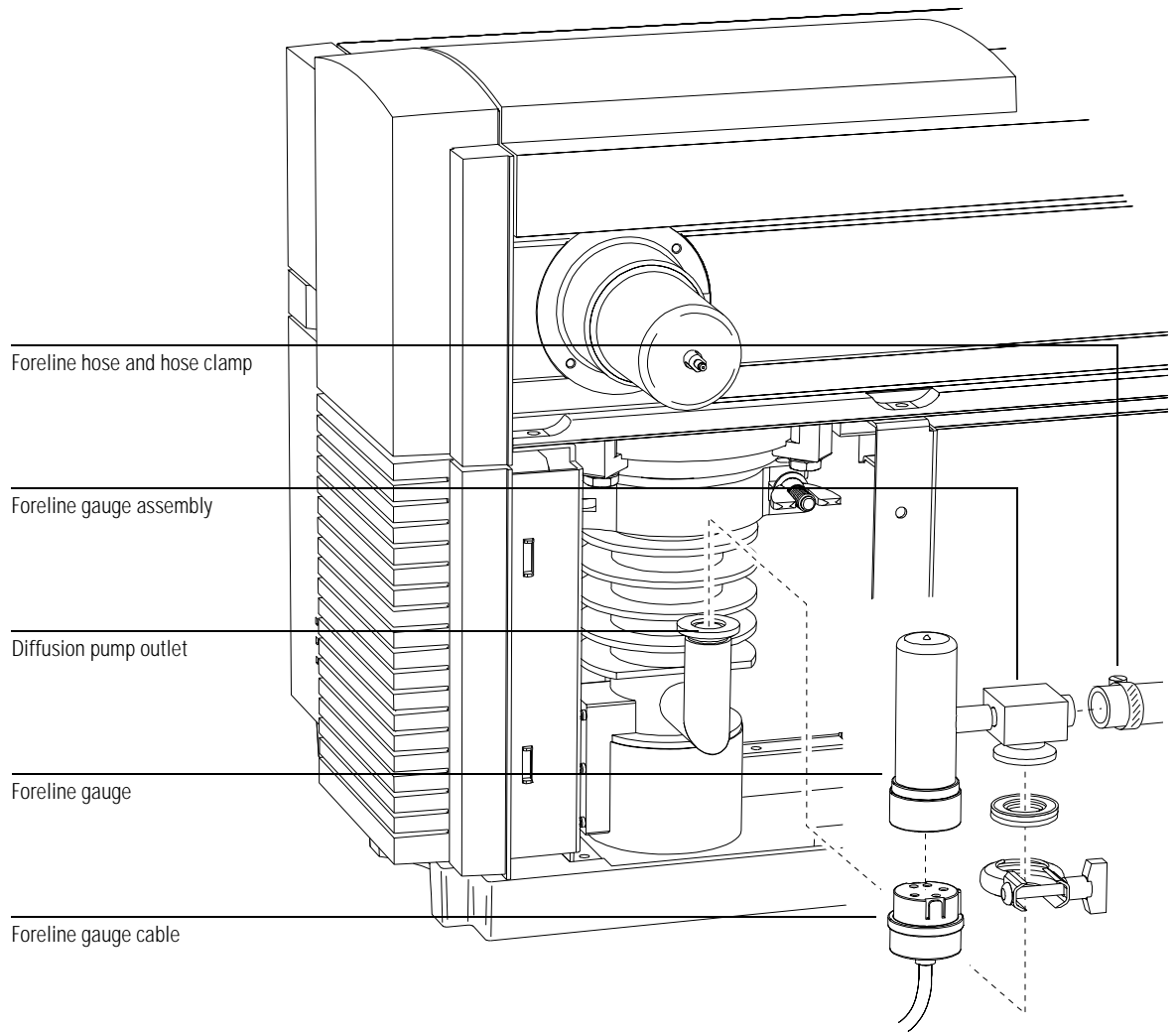

## To reinstall a foreline gauge

*Materials needed:* Foreline gauge assembly (G1099-60545)  
Screwdriver, flat-blade, large (8730-0002)

- 1 Connect a new foreline gauge assembly to the foreline hose.**
- 2 Tighten the hose clamp.**
- 3 Reconnect the foreline gauge cable to the foreline gauge.**
- 4 Reconnect the foreline gauge assembly to the diffusion pump outlet.**
- 5 Reconnect the MSD to the GC (page 120).**
- 6 If necessary, slide the foreline pump back under the vacuum manifold.**  
The foreline pump may be located on the floor, on the lab bench next to or behind the MSD, or under the vacuum manifold at the back of the MSD.
- 7 Pump down the MSD (page 58).**

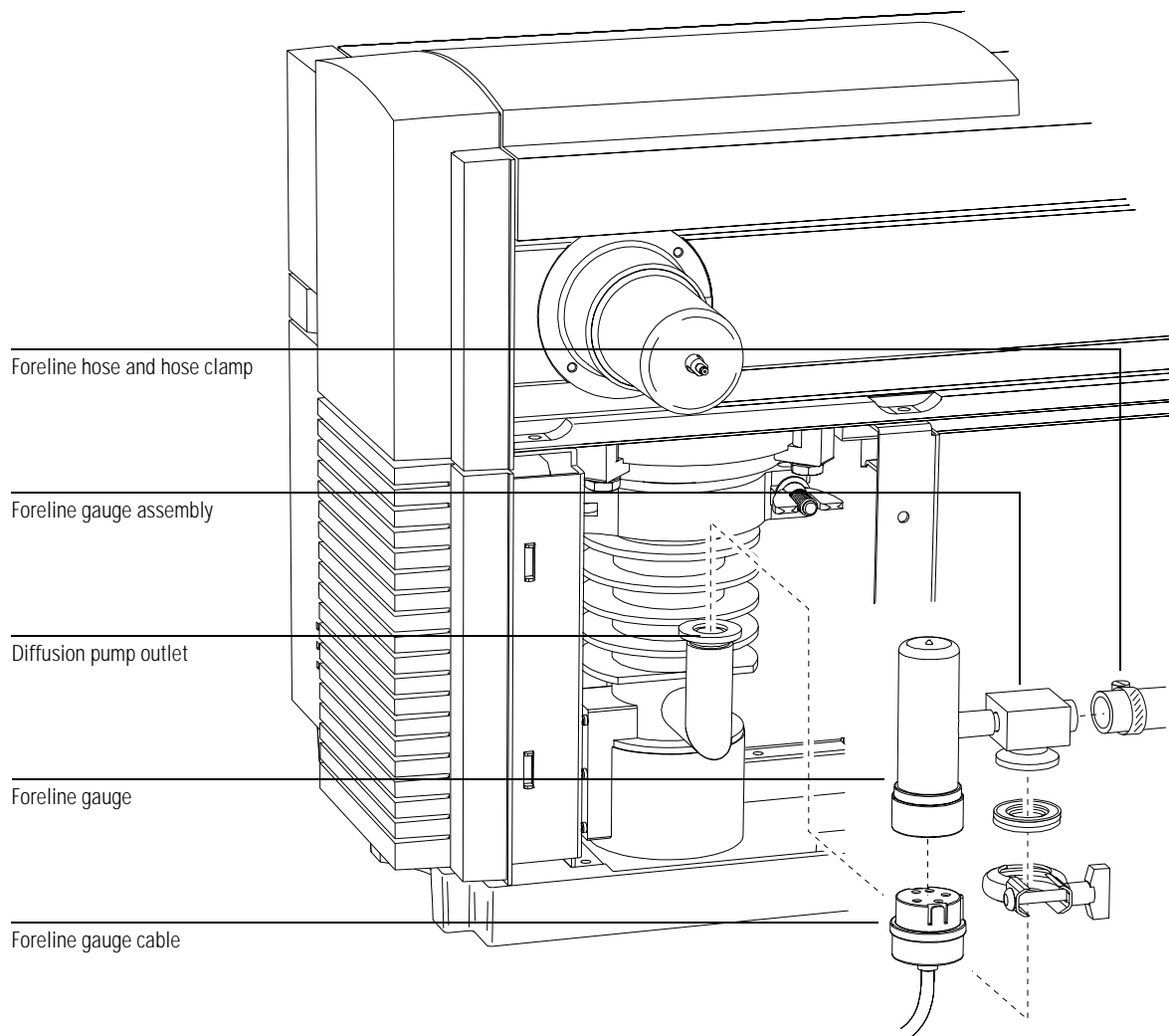

**To remove the calibration valve**

---

## To remove the calibration valve

*Materials needed:* Screwdriver, TORX T-15 (8710-1622)

- 1 Vent the MSD (page 52).**
- 2 Disconnect the calibration valve cable from the connector next to the fan.**
- 3 Loosen the collar and remove the calibration vial.**

Turn the collar counterclockwise as viewed from the bottom (vial side) of the thumbscrew. Just loosen the collar, do not remove it.
- 4 Remove the calibration valve from the front end plate.**

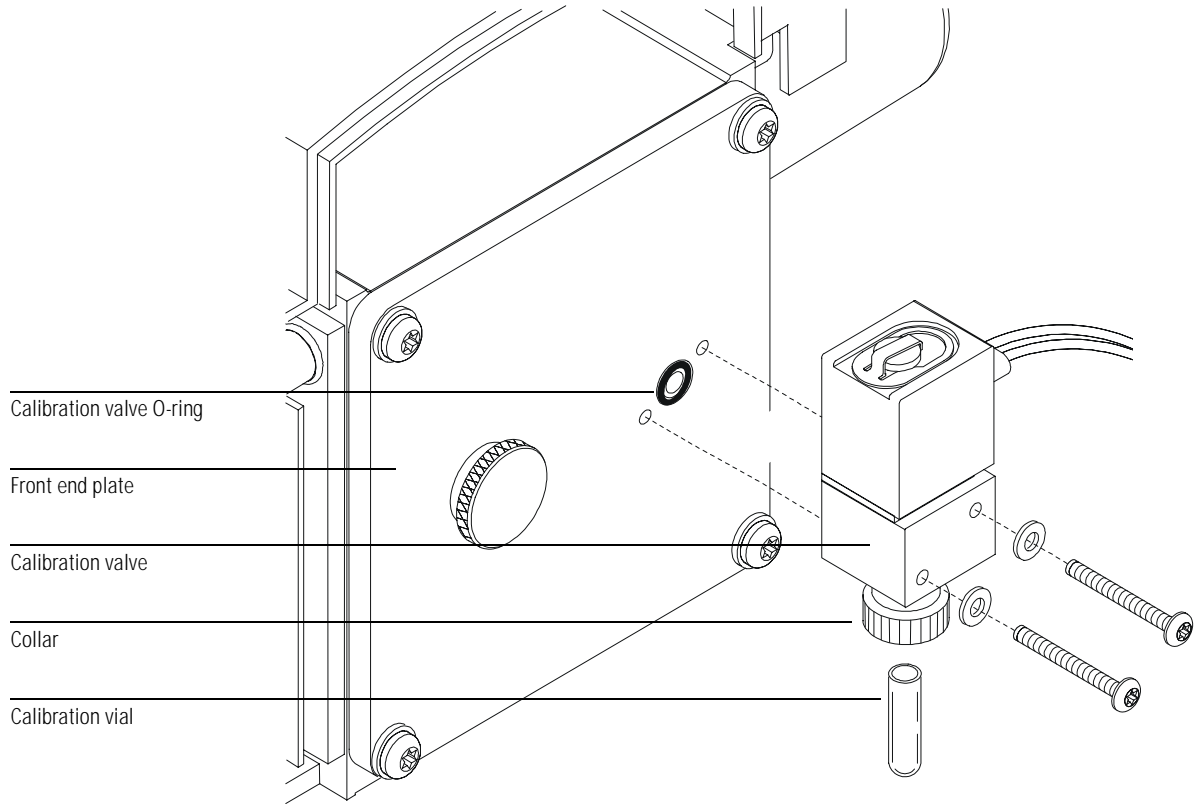

## To reinstall a calibration valve

*Materials needed:*

Calibration valve  
for diffusion pump (G1099-60200)  
for turbomolecular pump (G1099-60203)  
O-ring, for calibration valve (0905-1217) – replace if the old O-ring is damaged  
PFTBA (05971-60571) or other tuning compound  
Screwdriver, TORX T-15 (8710-1622)

- 1 Remove the old calibration valve (page 130).**
- 2 Make sure the calibration valve O-ring is in place.**  
If the O-ring is worn or damaged, replace it.
- 3 Install the calibration valve.**  
Tighten the screws that hold it in place. Make sure you use the calibration valve that matches the high vacuum pump in your MSD. The different calibration valves have different restrictors. Using the wrong valve will interfere with tuning.
- 4 Reconnect the calibration valve cable to the connector next to the fan.**
- 5 Remove the vial from the new calibration valve (page 122).**  
The valve is supplied with a vial already installed.
- 6 Fill and reinstall the calibration vial (page 124).**
- 7 Pump down the MSD (page 58).**
- 8 Select Purge Cal Valve from the Vacuum menu in the Diagnostics/Vacuum Control view.**

---

**CAUTION**

---

Failure to purge the calibration valve will result in damage to the filaments and detector.

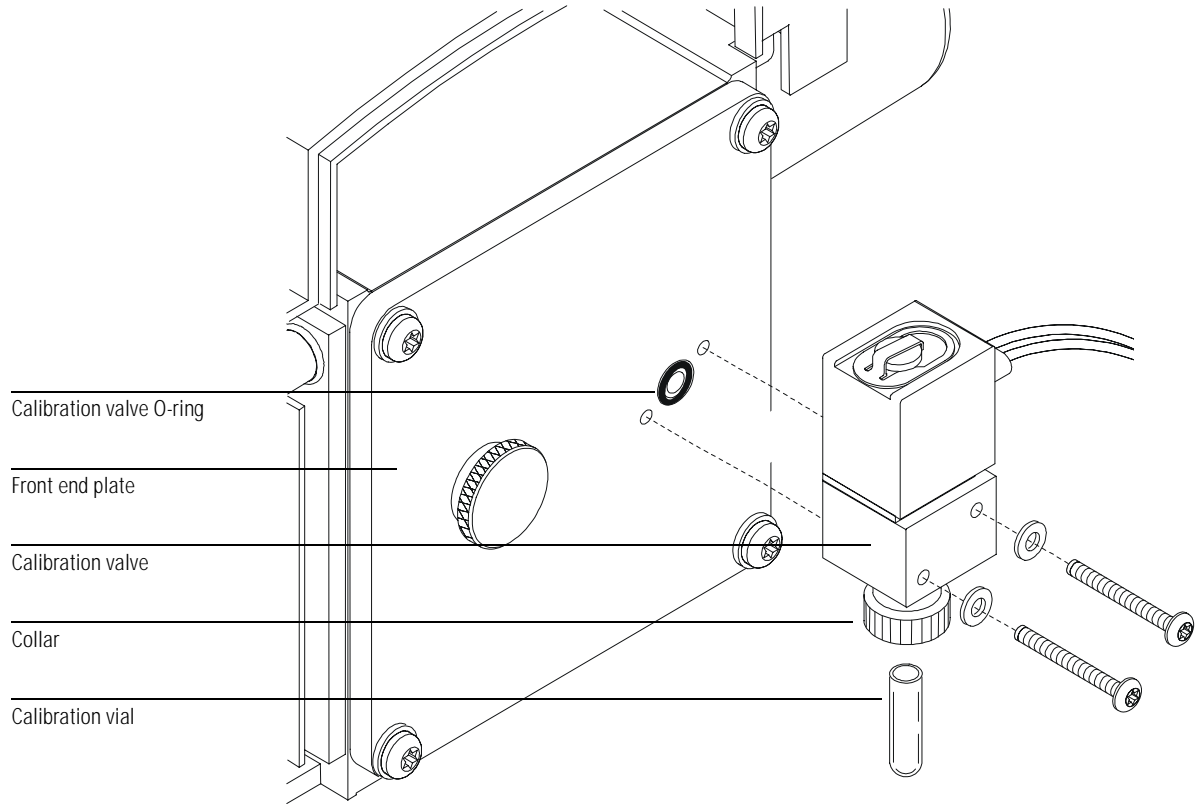

## To replace the fan for the high vacuum pump

*Materials needed:* Fan (3160-1037)  
Screwdriver, TORX T-15 (8710-1622)

- 1 Vent the MSD (page 52).**
- 2 Remove the upper and lower MSD covers (page 50).**
- 3 Disconnect the fan wiring from the connector on the MSD frame.**
- 4 Remove the 4 fan screws and remove the fan.**  
Keep the 4 screws.

---

### **W A R N I N G**

---

**Do not touch the high vacuum pump. The high vacuum pumps, especially the diffusion pump, operate at dangerously high temperatures and could still be hot enough to burn you.**

- 5 Disconnect the fan wiring and safety grill from the old fan.**  
The fan wiring ends in a small connector on the back of the fan
- 6 Connect the fan wiring and safety grill to the new fan.**
- 7 Install the new fan and reinstall the 4 screws.**

---

### **W A R N I N G**

---

**Make sure the safety grill that shields the fan blades is in place.**

- 8 Connect the fan wiring to the fan connector on the MSD frame.**
- 9 Reinstall the MSD covers.**
- 10 Pump down the MSD (page 58).**

To replace the fan for the high vacuum pump

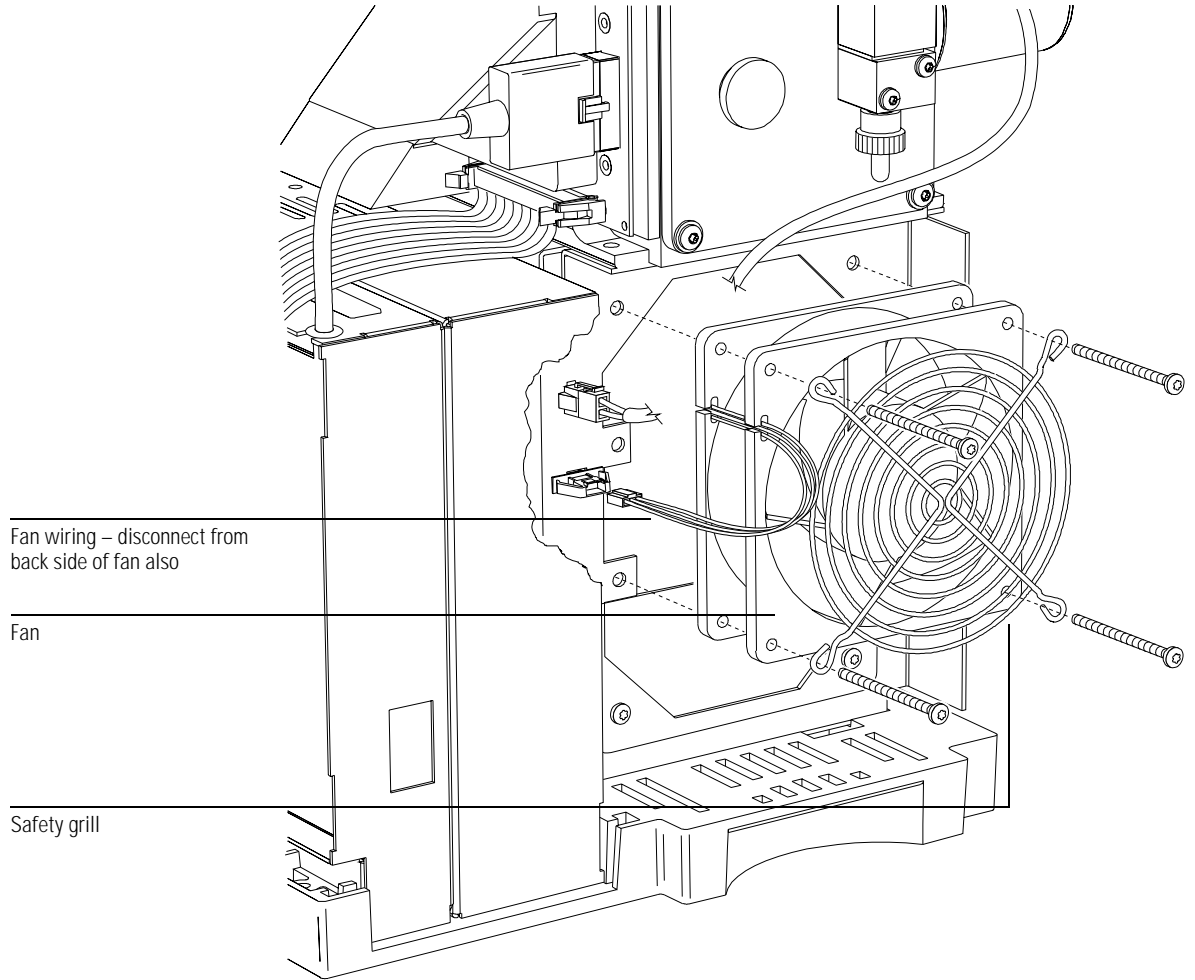

To remove the triode gauge tube

---

## To remove the triode gauge tube

*Materials needed:* Gloves, clean, lint-free  
large (8650-0030)  
small (8650-0029)

- 1 Vent the MSD (page 52).**
- 2 Disconnect the cable from the triode gauge tube.**

---

**W A R N I N G**

---

**Never connect or disconnect the cable from the triode gauge tube while the MSD is under vacuum. The stress could cause the tube to implode.**

- 3 Loosen the triode gauge collar by turning it counterclockwise.**  
Do not remove the collar.
- 4 Pull the triode gauge tube out of the collar.**
- 5 Remove the baffle from the open end of the triode gauge tube.**  
Wear clean gloves when handling the baffle. If you set the baffle down, make sure it is on a clean surface.

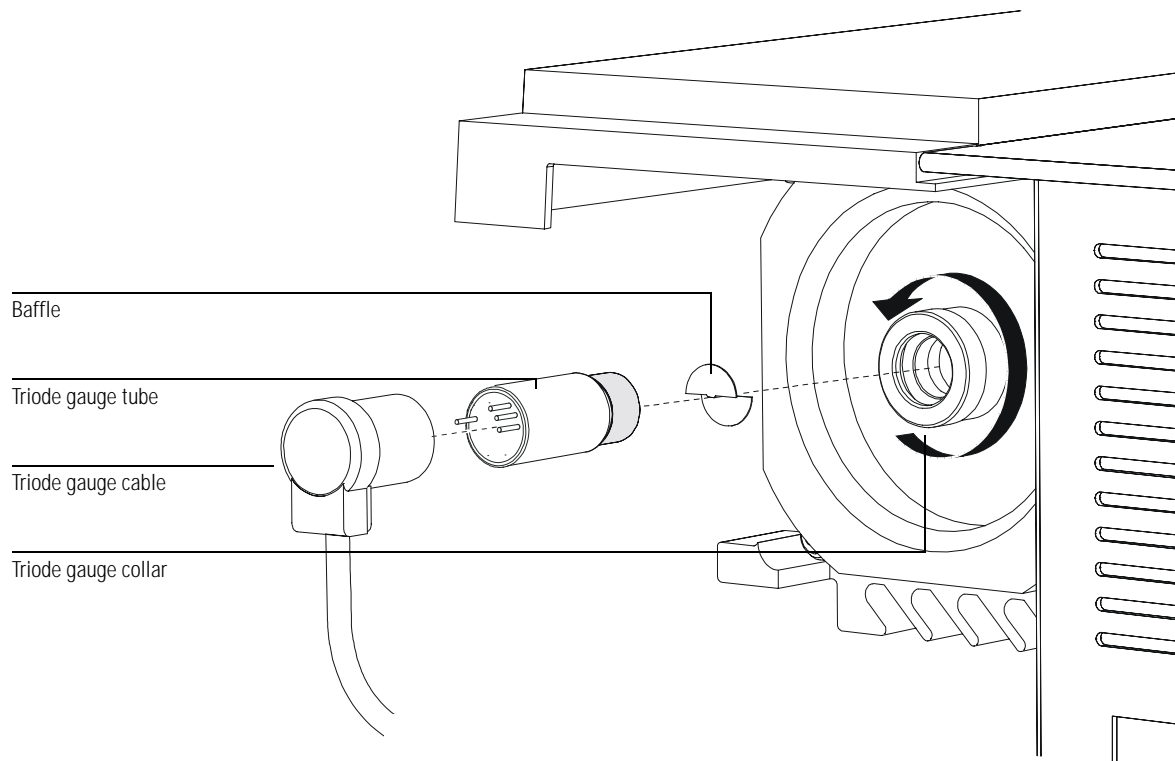

To reinstall a triode gauge tube

---

## To reinstall a triode gauge tube

*Materials needed:*

Gloves, clean, lint-free  
    large (8650-0030)  
    small (8650-0029)  
Triode gauge tube (0960-0897)

- 1 Remove the old triode gauge tube (page 136).**
- 2 Slide the baffle into the open end of the new triode gauge tube.**  
Wear clean gloves when handling the baffle and new triode gauge tube. If you set the baffle down, make sure it is on a clean surface.
- 3 Slide the triode gauge tube into the collar.**  
Leave 3 mm of the metal sleeve exposed. Be sure the pins are oriented as in the illustration.
- 4 Gently hand tighten the collar by turning it clockwise.**

---

**W A R N I N G**

---

**Do not overtighten; you can break the tube or damage the O-ring.**

- 5 Reconnect the cable from the gauge controller to the triode gauge tube.**  
Route the cable so it does not put stress on the triode gauge tube.

---

**W A R N I N G**

---

**Be careful when attaching the cable. Too much force can break the tube.**

- 6 Pump down the MSD (page 58).**

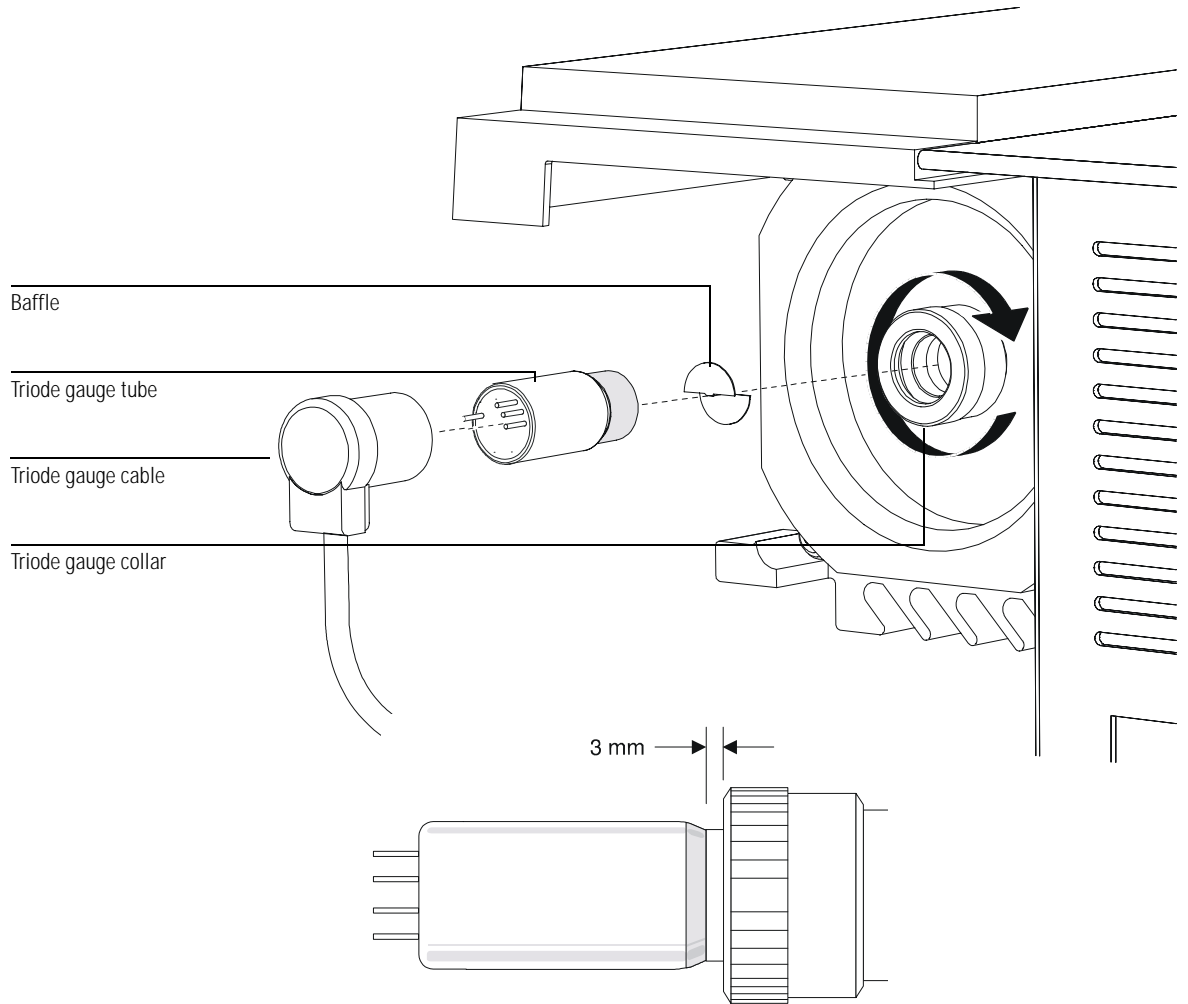

**To lubricate the side plate O-ring**

---

## To lubricate the side plate O-ring

*Materials needed:*

Cloths, clean (05980-60051)  
Gloves, clean, lint-free  
    large (8650-0030)  
    small (8650-0029)  
Grease, Apiezon L, high vacuum (6040-0289)

The side plate O-ring needs a thin coat of grease to ensure a good vacuum seal. If the side plate O-ring appears dry, or does not seal correctly, lubricate it using this procedure.

---

**CAUTION**

Vacuum seals other than the side plate O-ring and vent valve O-ring do not need to be lubricated. Lubricating other seals can interfere with their correct function.

- 1 Vent the MSD (page 52).**
- 2 Open the vacuum manifold (page 54).**
- 3 Use a clean, lint-free cloth or glove to spread a *thin* coat of high vacuum grease on the exposed surface of the O-ring.**

---

**CAUTION**

Excess grease can trap air and dirt. Grease on surfaces of the O-ring other than the exposed surface can trap air, resulting in air spikes during operation.

- 4 Use a clean, lint-free cloth or glove to wipe away excess grease.**  
If the O-ring looks shiny, there is too much grease on it.
- 5 Close the vacuum manifold (page 56).**
- 6 Pump down the MSD (page 56).**

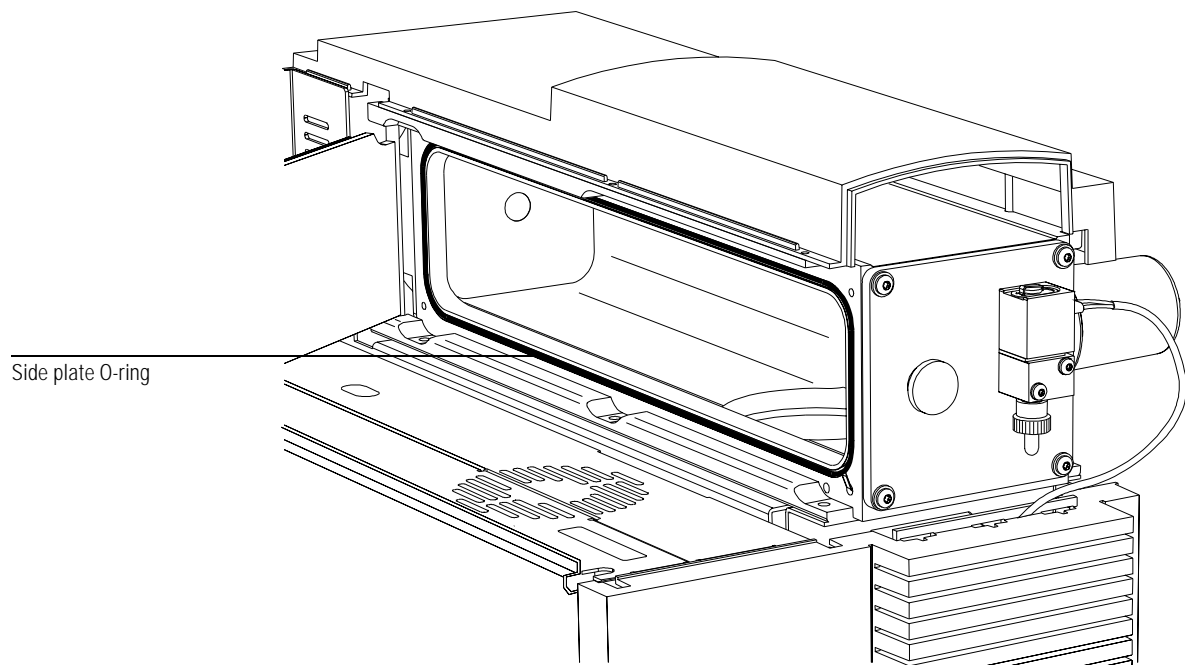

**To lubricate the vent valve O-ring**

---

## To lubricate the vent valve O-ring

*Materials needed:*

Cloths, clean (05980-60051)

Gloves, clean, lint-free

    large (8650-0030)

    small (8650-0029)

Grease, Apiezon L, high vacuum (6040-0289)

O-ring, vent valve (0905-1217) - replace if the old O-ring is worn or damaged

The vent valve O-ring needs a thin coat of lubrication to ensure a good vacuum seal and smooth operation. If the vent valve O-ring does not turn smoothly, or does not seal correctly, lubricate it using this procedure.

---

**CAUTION**

---

Vacuum seals other than the side plate O-ring and vent valve O-ring do not need to be lubricated. Lubricating other seals can interfere with their correct function.

- 1 Vent the MSD (page 52).**
- 2 Completely remove the vent valve knob.**
- 3 Inspect the O-ring.**  
If the O-ring appears damaged, replace it.
- 4 Use a clean, lint-free cloth or glove to spread a *thin* coat of high vacuum grease on the exposed surface of the O-ring.**

---

**CAUTION**

---

Excess grease can trap air and dirt. Grease on surfaces of the O-ring other than the exposed surface can trap air, resulting in air spikes during operation.

- 5 Use a clean, lint-free cloth or glove to wipe away excess grease.**  
If the O-ring looks shiny, there is too much grease on it.

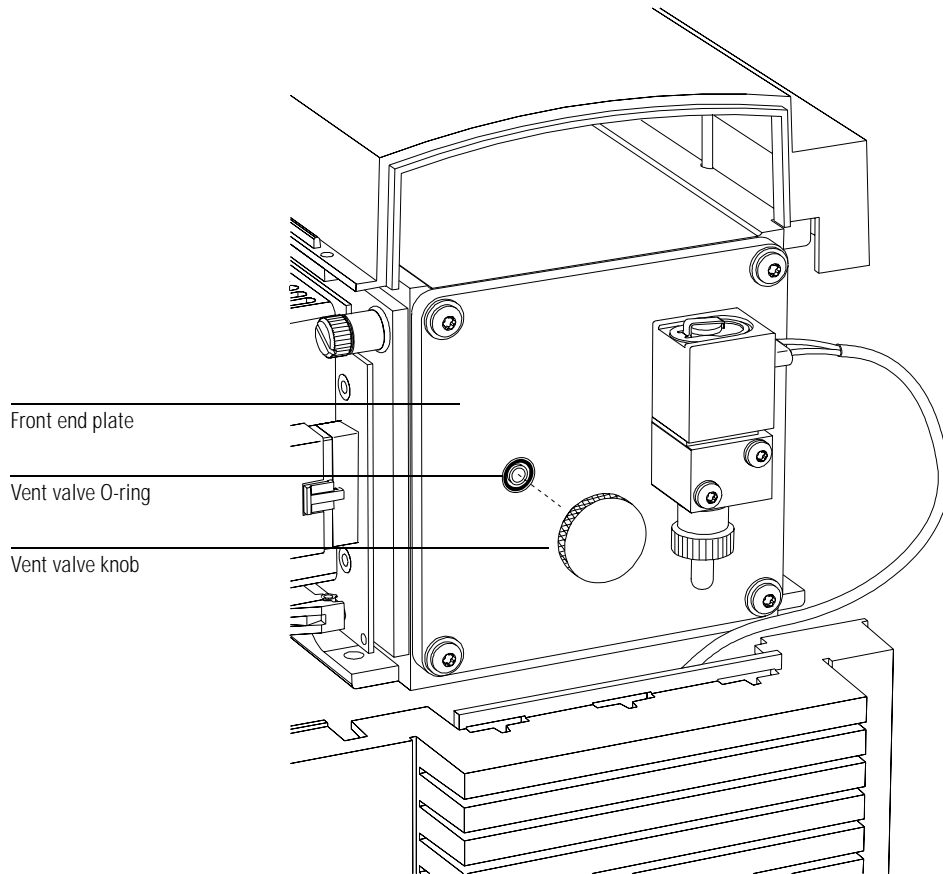

**6 Reinstall the vent valve knob.**

---

**CAUTION**

---

Be very careful when reinstalling the vent valve knob. It is very easy to cross thread the knob and damage the threads in the front end plate. Be sure the O-ring stays in place.

**7 Pump down the MSD (page 58).**

---

# Maintaining the analyzer

## ***The analyzer requires no periodic maintenance***

None of the analyzer components requires periodic maintenance. Some tasks, however, must be performed when MSD behavior indicates they are necessary. These tasks include:

- Cleaning the ion source
- Replacing filaments
- Replacing the electron multiplier horn

Chapter 3, *Troubleshooting the MSD*, on page 65 provides information about symptoms that indicate the need for analyzer maintenance. The troubleshooting material in the online help in the MSD ChemStation software provides more extensive information.

## ***Care must be taken during analyzer maintenance to keep components clean***

Analyzer maintenance involves opening the vacuum manifold and removing parts from the analyzer. During analyzer maintenance procedures, care must be taken to avoid contaminating the analyzer or interior of the vacuum manifold. Clean gloves should be worn during all analyzer maintenance procedures. After cleaning, parts must be thoroughly baked out before they are reinstalled. After cleaning, analyzer parts should be placed only on clean, lint-free cloths.

---

### **CAUTION**

---

If not done correctly, analyzer maintenance can introduce contaminants into the MSD.

---

### **WARNING**

---

**The analyzer operates at high temperatures. Do not touch any part until you are sure it is cool.**

***Some parts are vulnerable to damage from electrostatic discharge***

The wires, contacts, and cables connected to the analyzer components can carry electrostatic discharges (ESD) to the electronics boards to which they are connected. This is especially true of the mass filter (quadrupole) contact wires which can conduct ESD to sensitive components on the side board. ESD damage may not cause immediate failure but will gradually degrade performance and stability. See the material on page 100 for more information.

---

**C A U T I O N**

---

Electrostatic discharges to analyzer components are conducted to the side board where they can damage sensitive components. Wear a grounded anti-static wrist strap (see page 100) and take other anti-static precautions **before** you open the vacuum manifold.

***Some analyzer parts should not be disturbed***

The mass filter (quadrupole) requires no periodic maintenance. In general, the mass filter should never be disturbed. In the event of extreme contamination, it can be cleaned, but such cleaning should only be done by a trained Hewlett-Packard service representative.

---

**C A U T I O N**

---

Incorrect handling or cleaning of the mass filter can damage it and have a serious, negative effect on instrument performance.

***More information is available***

If you need more information about the locations or functions of analyzer components, refer to Chapter 7, *Analyzer*, on page 215.

Most of the procedures in this chapter are illustrated with video clips in the HP 5973 MSD Reference Collection CD-ROM.

To remove the ion source

---

## To remove the ion source

*Materials needed:* Gloves, clean, lint-free  
large (8650-0030)  
small (8650-0029)  
Pliers, long-nose (8710-1094)

- 1 Vent the MSD (page 52).**
- 2 Open the vacuum manifold (page 54).**  
Make sure you use an anti-static wrist strap and take other anti-static precautions before touching analyzer components.
- 3 Disconnect the 7 colored wires from the ion source.**

---

**CAUTION**

---

Pull on the connectors, not on the wires.

- 4 Disconnect the wires for the ion source heater and temperature sensor from the feedthrough board.**
- 5 Remove the thumbscrews that hold the ion source in place.**
- 6 Pull the ion source out of the source radiator.**

---

**WARNING**

---

The analyzer operates at high temperatures. Do not touch any part until you are sure it is cool.

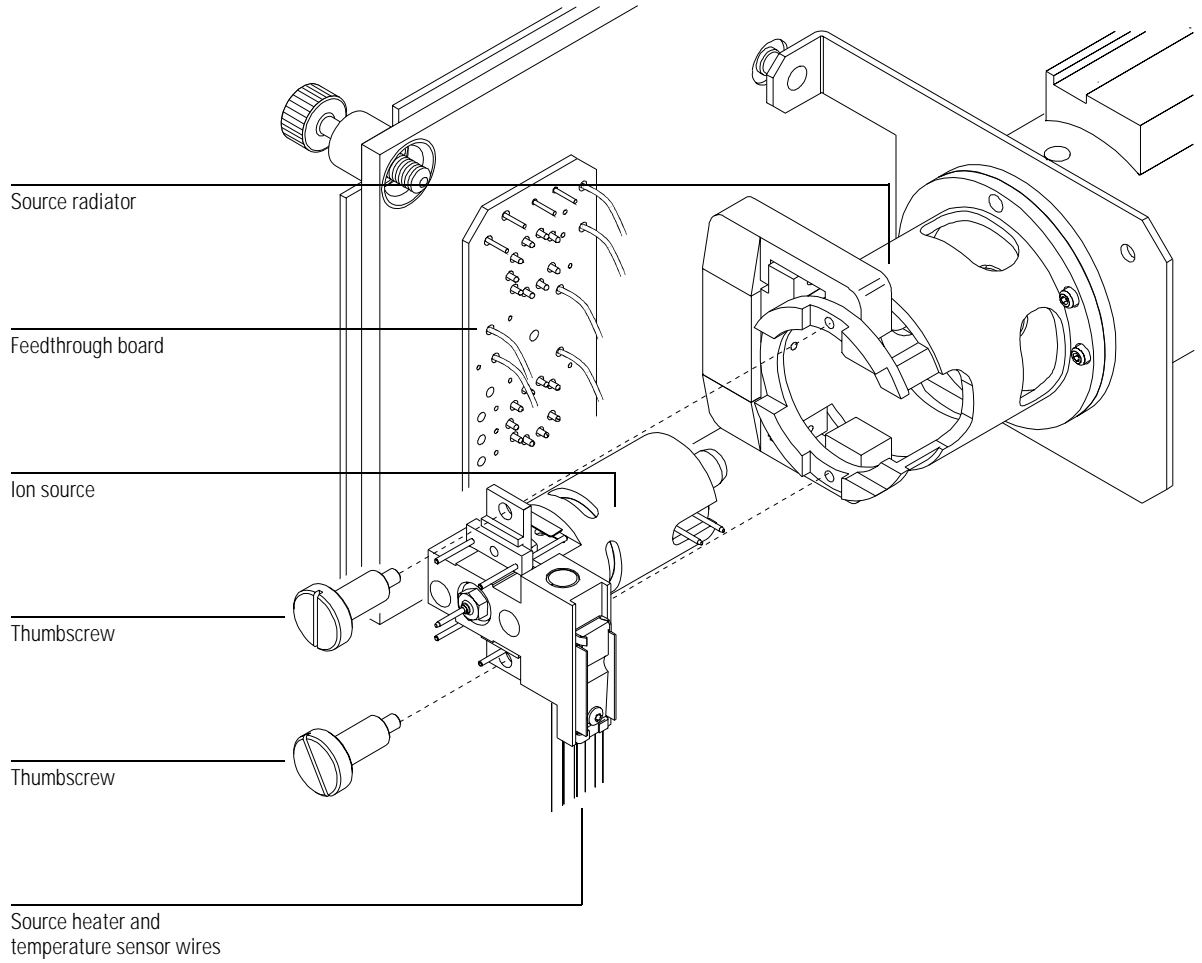

## To disassemble the ion source

*Materials needed:*

Gloves, clean, lint-free  
    large (8650-0030)  
    small (8650-0029)  
Hex ball driver, 1.5-mm (8710-1570)  
Hex ball driver, 2.0-mm (8710-1804)  
Hex nut driver, 5.5-mm (8710-1220)  
Wrench, open-end, 10-mm (8710-2353)

**1 Remove the ion source (page 146).**

**2 Remove the filaments.**

**3 Separate the repeller assembly from the source body.**

The repeller assembly includes the source heater assembly, repeller, and related parts.

**4 Remove the repeller.**

**5 Unscrew the interface socket.**

A 10-mm open-end wrench fits on the flats on the interface socket.

**6 Remove the setscrew for the lenses.**

**7 Push the lenses out of the source body.**

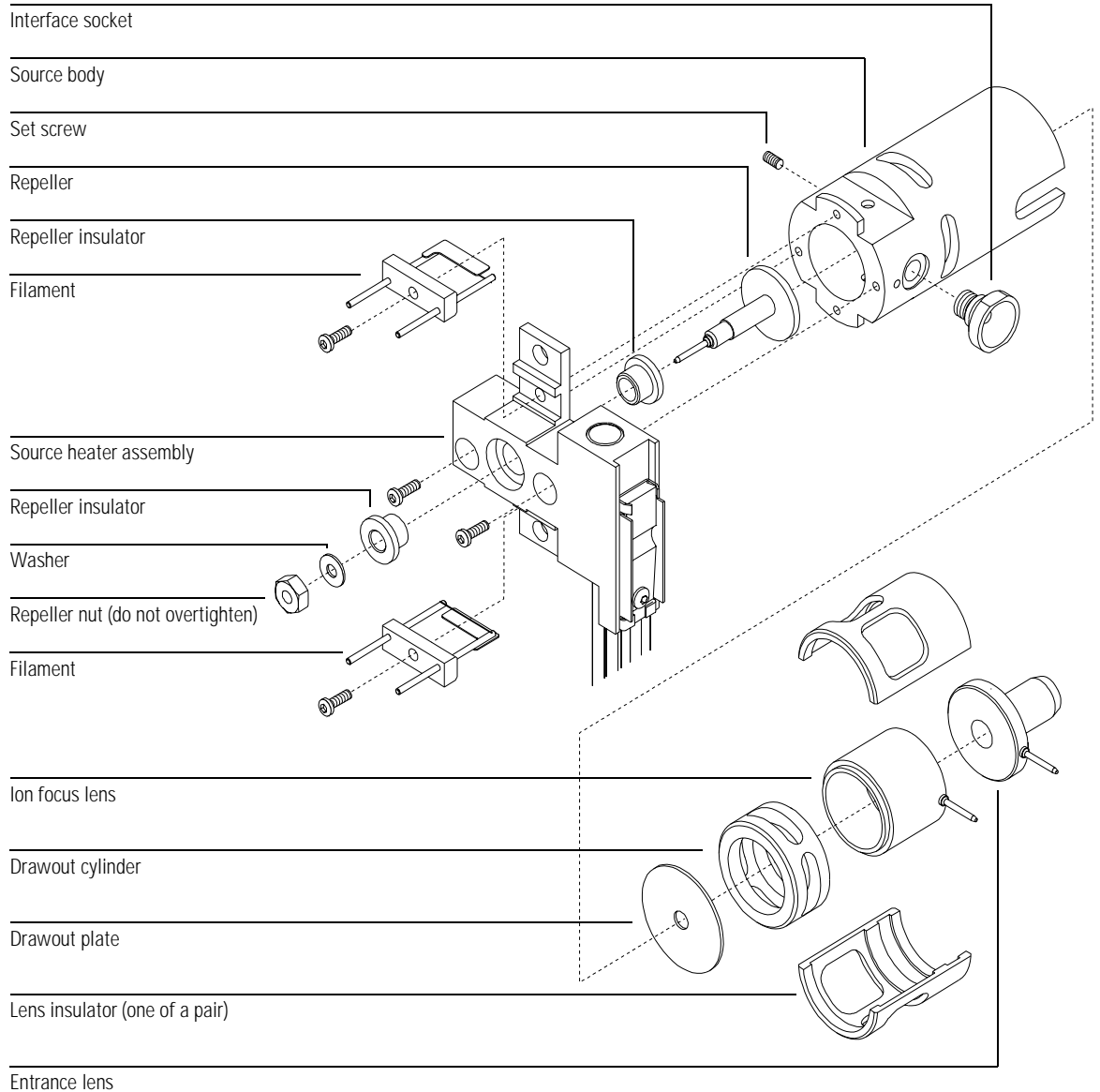

To clean the ion source

---

## To clean the ion source

*Materials needed:*

- Abrasive paper (5061-5896)
- Alumina abrasive powder (8660-0791)
- Aluminum foil, clean
- Cloths, clean (05980-60051)
- Cotton swabs (5080-5400)
- Glass beakers, 500 ml
- Gloves, clean, lint-free
  - large (8650-0030)
  - small (8650-0029)
- Solvents
  - acetone, reagent-grade
  - methanol, reagent-grade
  - methylene chloride, reagent grade
- Ultrasonic bath

**1 Disassemble the ion source (page 148).**

**2 Collect the following parts to be cleaned:**

- Repeller
- Interface socket
- Source body
- Drawout plate
- Drawout cylinder
- Ion focus lens
- Entrance lens

These are the parts that contact the sample or ion beam. The other parts normally should not require cleaning.

---

**CAUTION**

---

If insulators are dirty, clean them with a cotton swab dampened with reagent-grade methanol. If that does not clean the insulators, replace them. Do not abrasively or ultrasonically clean the insulators.

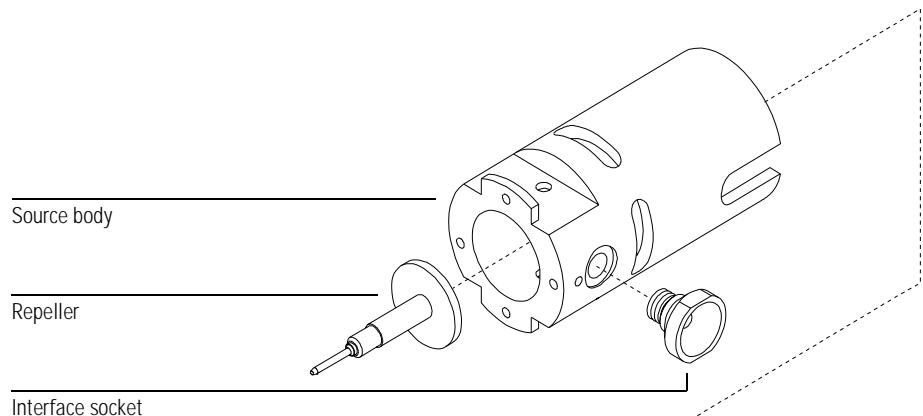

Source body

Repeller

Interface socket

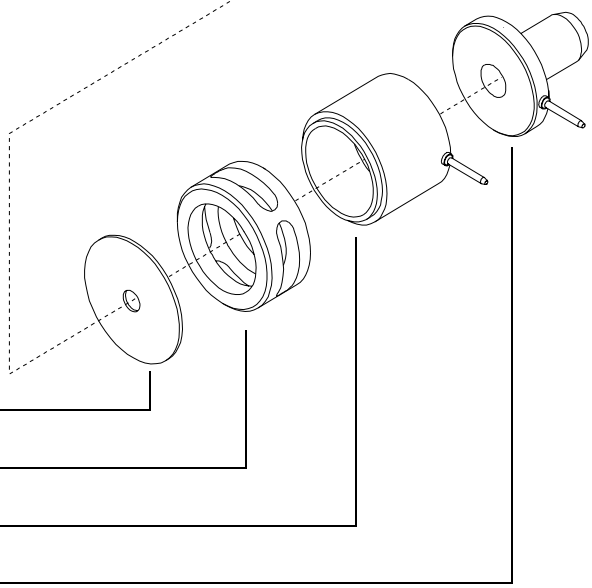

Drawout plate

Drawout cylinder

Ion focus lens

Entrance lens

## 4 Maintaining the MSD

### To clean the ion source

#### *Major contamination*

In the event of a diffusion pump backstream or other major contamination, the other source components must be cleaned (ultrasonically but not abrasively) or replaced.

---

#### **C A U T I O N**

---

The filaments, source heater assembly, and insulators cannot be cleaned ultrasonically. Replace these components if major contamination occurs.

### **3 Abrasively clean the surfaces that contact the sample or ion beam.**

Use an abrasive slurry of alumina powder and reagent-grade methanol on a cotton swab. Use only enough force to remove the discolorations; polishing the parts is not necessary. Also abrasively clean the discolorations where electrons from the filaments enter the source body.

### **4 Rinse away all abrasive residue with reagent-grade methanol.**

Make sure all abrasive residue is rinsed away *before* ultrasonic cleaning. If the methanol becomes cloudy or contains visible particles, rinse again.

### **5 Separate the parts that were abrasively cleaned from the parts that were not abrasively cleaned.**

### **6 Ultrasonically clean the parts for 15 minutes in each of the following solvents:**

Ultrasonically clean each group of parts separately.

- Methylene chloride (reagent-grade)
- Acetone (reagent-grade)
- Methanol (reagent-grade)

---

#### **W A R N I N G**

---

**All of these solvents are hazardous. Work in a fume hood and take all appropriate precautions.**

### **7 Place the parts in a clean beaker. *Loosely* cover the beaker with clean aluminum foil.**

**8 Dry the cleaned parts in an oven at 100° – 150°C for 30 minutes.**

---

**W A R N I N G**

---

**Let these parts cool before you handle them.**

Take care to avoid recontaminating cleaned and dried parts. Put on new, clean gloves before handling the parts. Do not set the cleaned parts on a dirty surface. Set them only on clean, lint-free cloths.

## To reassemble the ion source

*Materials needed:*

Gloves, clean, lint-free  
    large (8650-0030)  
    small (8650-0029)  
Hex ball driver, 1.5-mm (8710-1570)  
Hex ball driver, 2.0-mm (8710-1804)  
Hex nut driver, 5.5-mm (8710-1220)  
Wrench, open-end, 10-mm (8710-2353)

- 1 Slide the drawout plate and the drawout cylinder into the source body.**
- 2 Assemble the ion focus lens, entrance lens, and lens insulators.**
- 3 Slide the assembled parts into the source body.**
- 4 Install the setscrew that holds the lenses in place.**
- 5 Reinstall the repeller, repeller insulators, washer, and repeller nut into the source heater assembly.**

The resulting assembly is called the repeller assembly.

---

**CAUTION**

---

Do not overtighten the repeller nut, or the ceramic repeller insulators will break when the source heats up. The nut should only be “finger-tight”.

- 6 Reconnect the repeller assembly to the source body.**

The repeller assembly includes the source heater assembly, repeller, and related parts.

- 7 Reinstall the filaments.**
- 8 Reinstall the interface socket.**

---

**CAUTION**

---

Do not overtighten the interface socket. Overtightening could strip the threads.

---

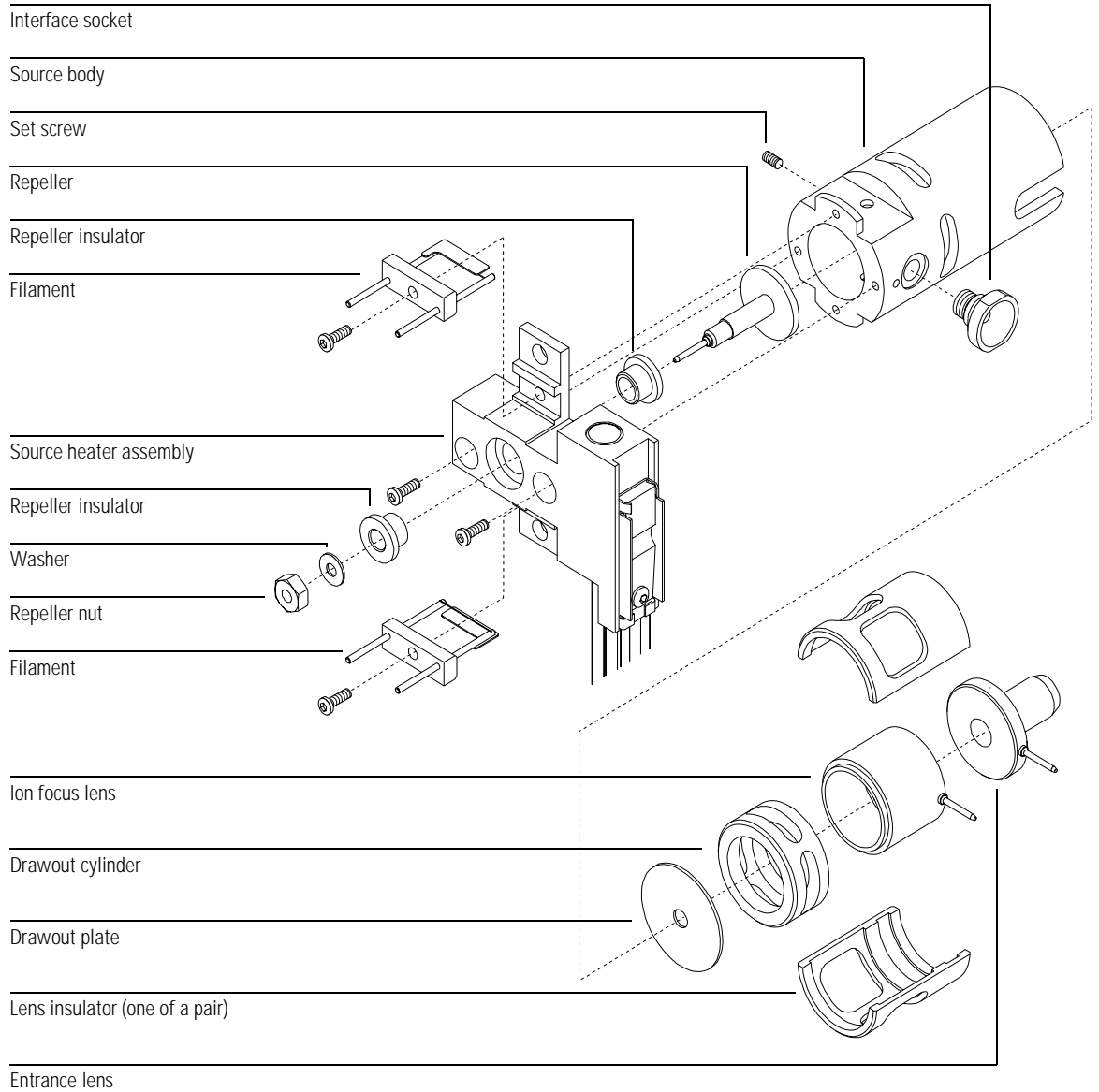

## To reinstall the ion source

*Materials needed:* Gloves, clean, lint-free  
large (8650-0030)  
small (8650-0029)  
Pliers, long-nose (8710-1094)

- 1 Slide the ion source into the source radiator.**
- 2 Install and hand tighten the source thumbscrews.**  
Do not overtighten the thumbscrews.
- 3 Reconnect the 7 colored wires to the appropriate pins on the ion source.**

Wire color	Connects to
Blue	Entrance lens
Orange	Ion focus
White	Filament 1 (top filament)
Red	Repeller
Black	Filament 2 (bottom filament)

- 4 Reconnect the source heater and temperature sensor wires to the pins on the feedthrough board.**
- 5 Close the vacuum manifold (page 56).**
- 6 Pump down the MSD (page 58).**

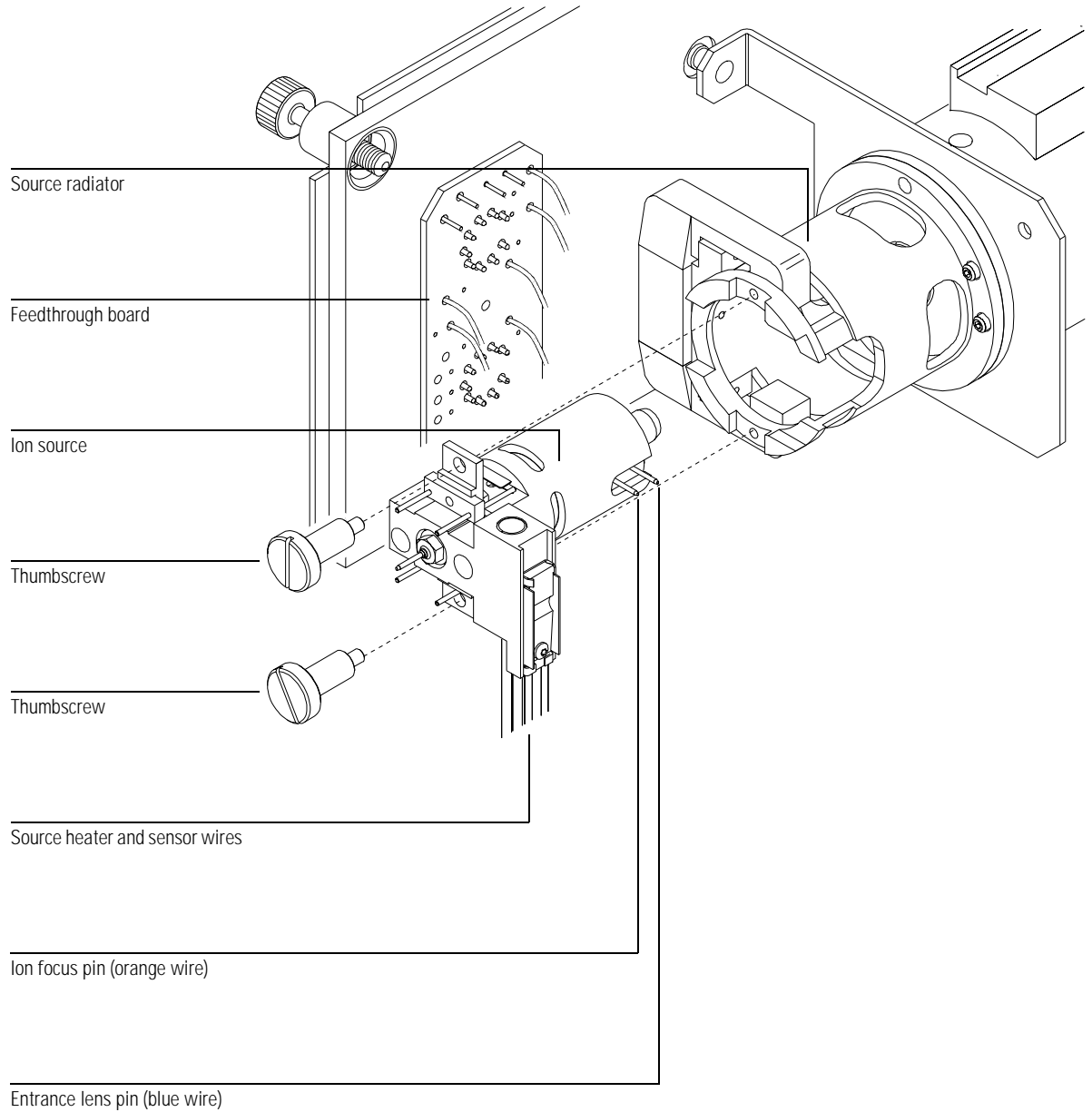

**To remove a filament**

---

**To remove a filament**

*Materials needed:*

Gloves, clean, lint-free  
    large (8650-0030)  
    small (8650-0029)  
Hex ball driver, 1.5-mm (8710-1570)

- 1 Vent the MSD (page 52).**
- 2 Open the vacuum manifold (page 54).**
- 3 Remove the ion source (page 146).**
- 4 Remove the filament(s) to be replaced.**

---

**W A R N I N G**

---

**The analyzer operates at high temperatures. Do not touch any part until you are sure it is cool.**

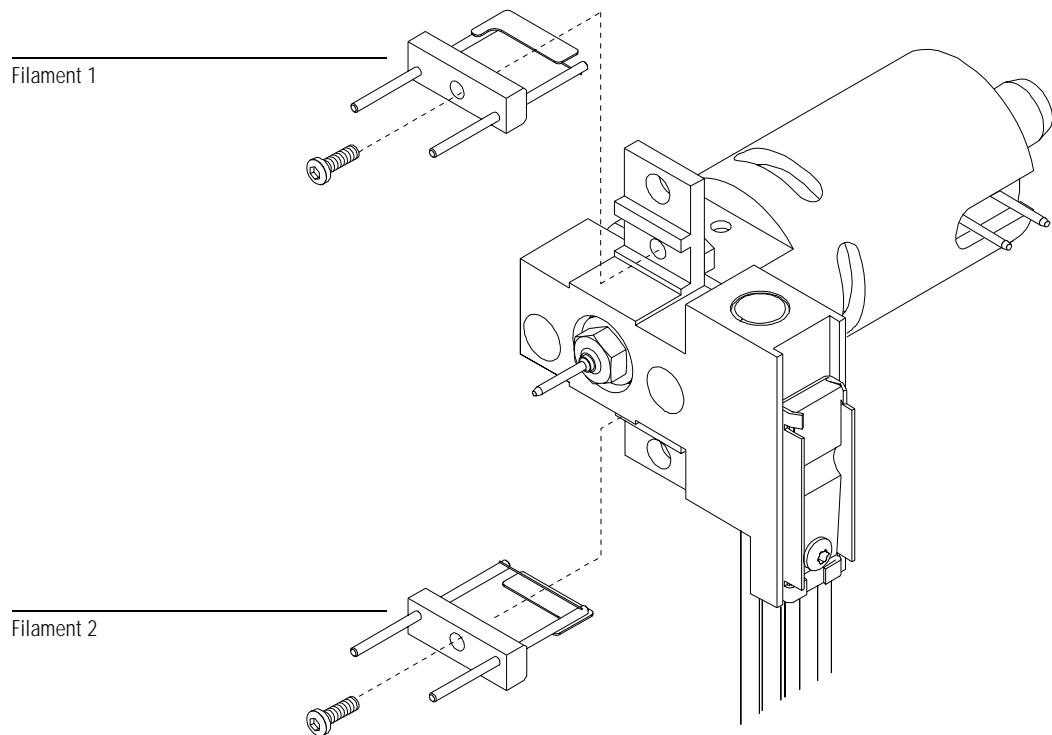

## To reinstall a filament

*Materials needed:*

Filament assembly (G1099-60053)  
Gloves, clean, lint-free  
    large (8650-0030)  
    small (8650-0029)  
Hex ball driver, 1.5-mm (8710-1570)

- 1 Install the new filament.**
- 2 Reinstall the ion source (page 156).**
- 3 Close the vacuum manifold (page 56).**
- 4 Pump down the MSD (page 58).**
- 5 Autotune the MSD (page 48).**
- 6 In the Edit Parameters dialog box (Instrument/Edit MS Tune Parameters), select the other filament.**
- 7 Autotune the MSD again.**
- 8 Select and use the filament that give the best results.**  
If you decide to use the first filament, run Autotune again to make sure the tune parameters are compatible with the filament.
- 9 Select Save Tune Parameters from the File menu.**

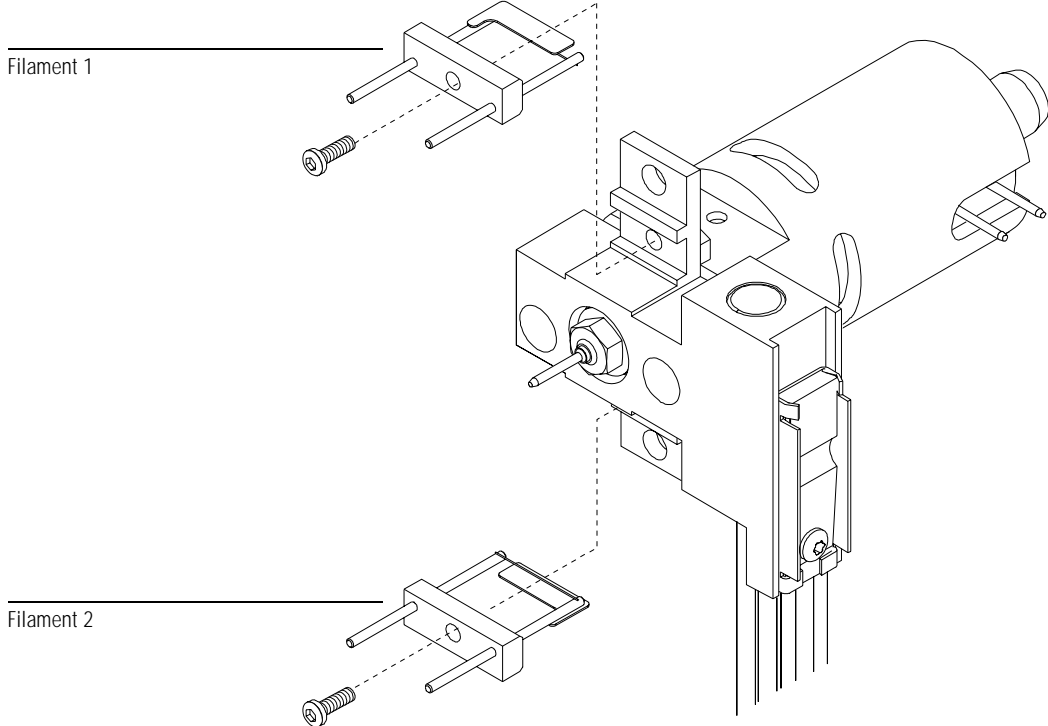

## To remove the heater and sensor from the ion source

*Materials needed:*

Gloves, clean, lint-free  
    large (8650-0030)  
    small (8650-0029)  
Hex ball driver, 1.5-mm (8710-1570)  
Hex ball driver, 2.0-mm (8710-1804)  
Hex nut driver, 5.5-mm (8710-1220)

**1 Vent the MSD (page 52).**

**2 Open the vacuum manifold (page 54).**

**3 Remove the ion source from the source radiator (page 146).**

**4 Remove the filaments.**

**5 Remove the repeller assembly.**

The repeller assembly includes the source heater assembly, repeller, and related parts.

**6 Remove the repeller nut, washer, repeller insulators, and repeller.**

You do not need to remove the heater and temperature sensor from the heater block. The new source heater assembly includes all three parts already assembled.

To remove the heater and sensor from the ion source

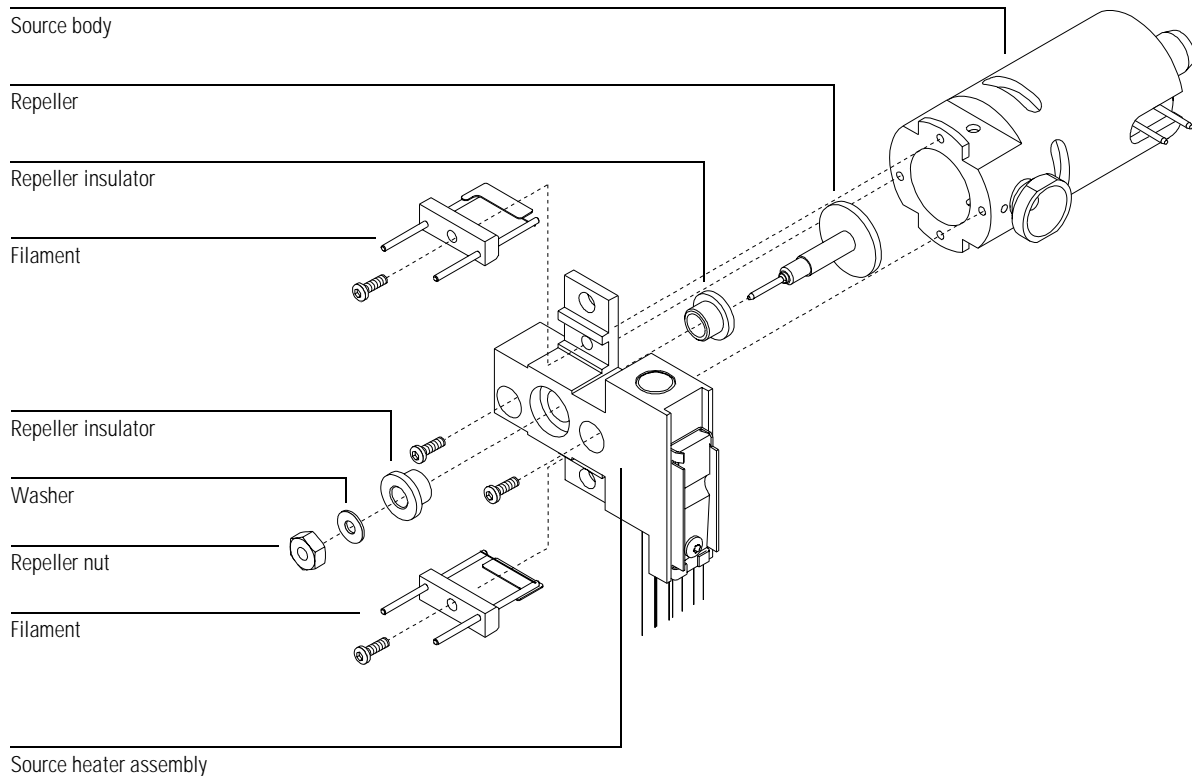

## To reinstall the heater and sensor in the ion source

*Materials needed:*

Gloves, clean, lint-free  
    large (8650-0030)  
    small (8650-0029)  
Hex ball driver, 1.5-mm (8710-1570)  
Hex ball driver, 2.0-mm (8710-1804)  
Hex nut driver, 5.5-mm (8710-1220)  
Source heater assembly (G1099-60177)

**1 Unpack the new source heater assembly.**

The heater, temperature sensor, and heater block are already assembled.

**2 Reinstall the repeller, repeller insulators, washer, and repeller nut.**

The resulting assembly is called the repeller assembly.

---

**CAUTION**

---

Do not overtighten the repeller nut, or the ceramic repeller insulators will break when the source heats up. The nut should only be "finger-tight".

**3 Connect the repeller assembly to the source body.**

**4 Reinstall the filaments.**

**5 Reinstall the ion source in the source radiator (page 156).**

Do not forget to reconnect the wires from the feedthrough board to the ion source.  
Do not forget to reconnect the heater and temperature sensor wires to the feedthrough board.

**6 Close the vacuum manifold (page 56).**

**7 Pump down the MSD (page 58).**

To reinstall the heater and sensor in the ion source

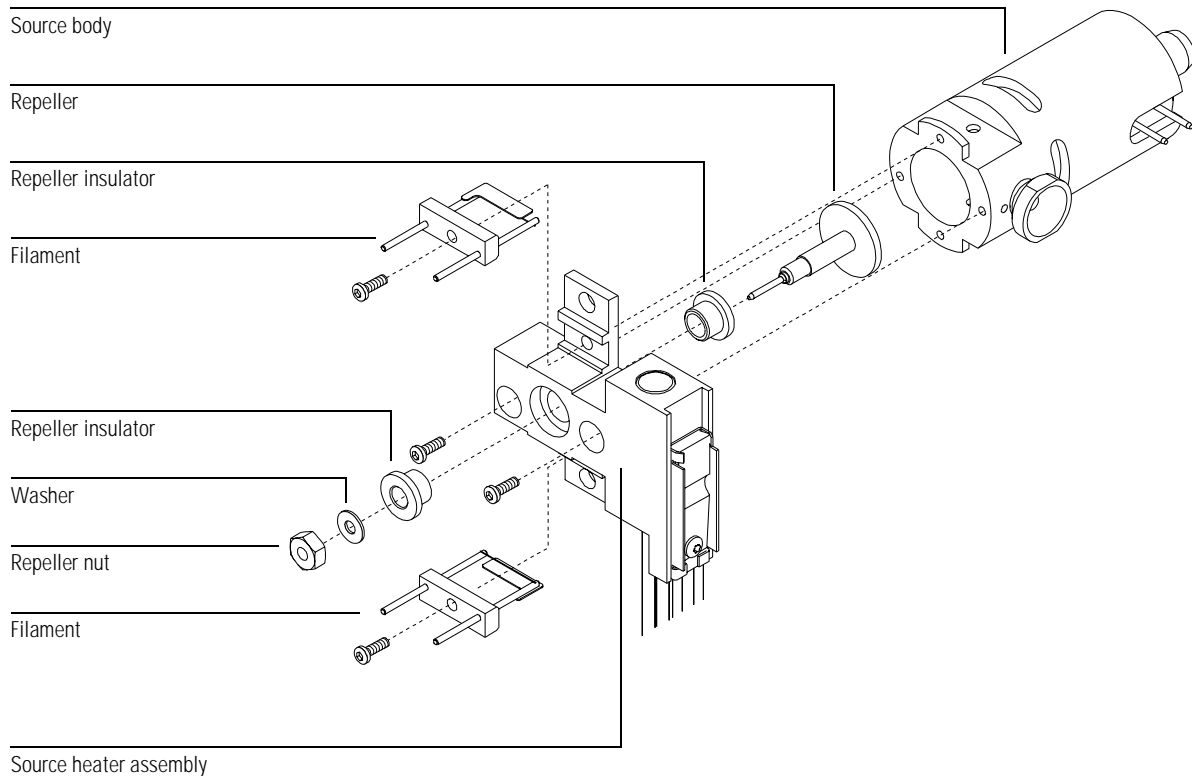

To remove the heater and sensor from the mass filter

---

## To remove the heater and sensor from the mass filter

*Materials needed:*

Gloves, clean, lint-free  
    large (8650-0030)  
    small (8650-0029)  
Hex ball driver, 1.5-mm (8710-1570)  
Hex ball driver, 2.0-mm (8710-1804)

- 1 Vent the MSD (page 52).**
- 2 Open the vacuum manifold (page 54).**
- 3 Disconnect the mass filter heater and temperature sensor wires from the feedthrough board.**
- 4 Remove the mass filter heater assembly from the mass filter radiator.**

---

**CAUTION**

---

Do not touch the mass filter contact leads. This could cause ESD damage to the side board.

To remove the heater and sensor from the mass filter

Mass filter contact lead –  
do not touch!

Mass filter radiator

Mass filter heater assembly

Feedthrough board

Mass filter contact lead –  
do not touch!

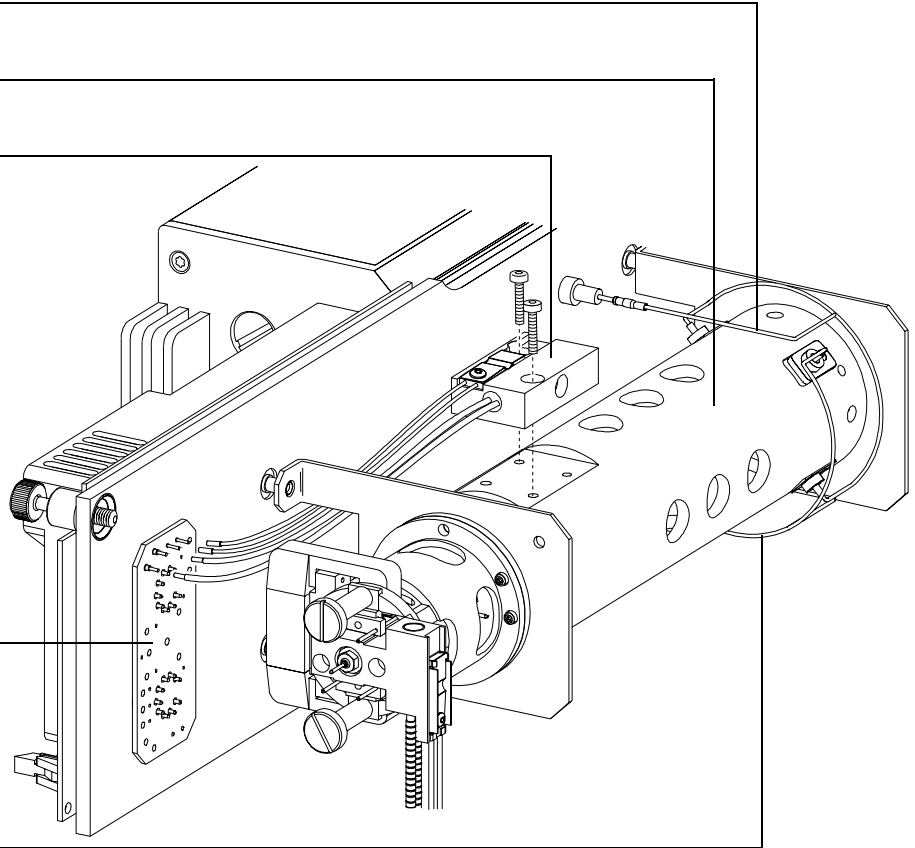

## To reinstall the heater and sensor in the mass filter

*Materials needed:*

Gloves, clean, lint-free  
    large (8650-0030)  
    small (8650-0029)  
Hex ball driver, 1.5-mm (8710-1570)  
Hex ball driver, 2.0-mm (8710-1804)  
Mass filter heater assembly (G1099-60172)

**1 Unpack the new mass filter heater assembly.**

The heater, temperature sensor, and heater block are already assembled.

**2 Install the heater assembly on top of the mass filter radiator.**

**3 Connect the heater and temperature sensor wires to the feedthrough board.**

**4 Close the vacuum manifold (page 56).**

**5 Pump down the MSD (page 58).**

---

**CAUTION**

---

Do not touch the mass filter contact leads. This could cause ESD damage to the side board.

To reinstall the heater and sensor in the mass filter

Mass filter contact lead –  
do not touch!

Mass filter radiator

Mass filter heater assembly

Feedthrough board

Mass filter contact lead –  
do not touch!

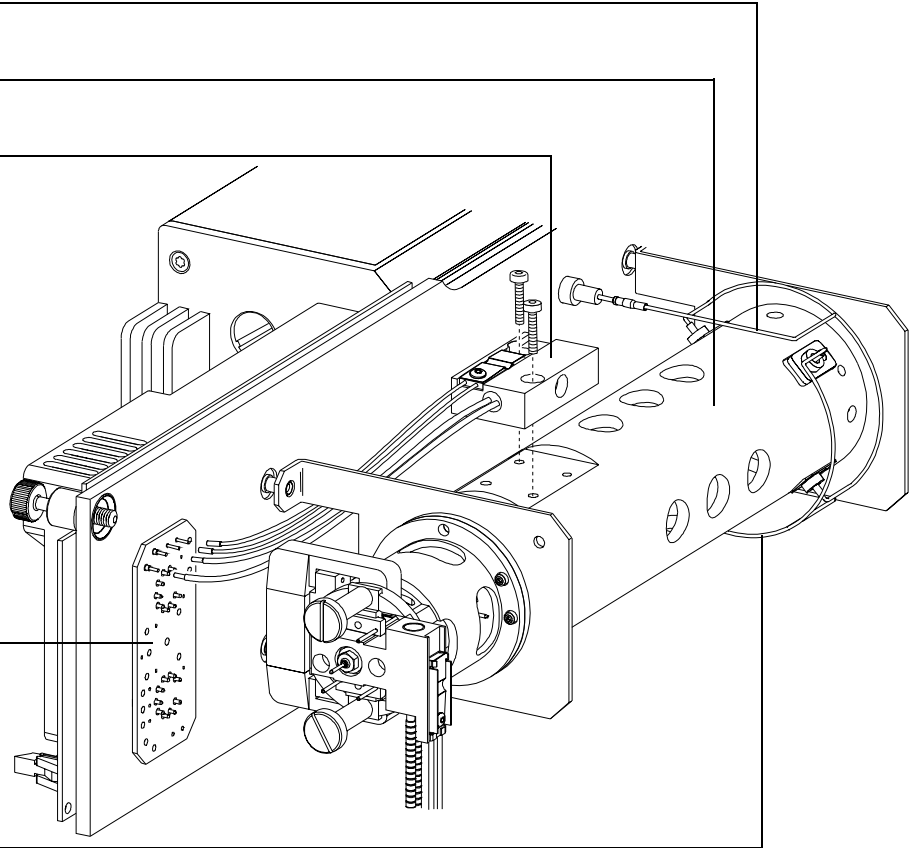

## To replace the electron multiplier horn

*Materials needed:* Electron multiplier horn (05971-80103)  
Gloves, clean, lint-free  
    large (8650-0030)  
    small (8650-0029)

**1 Vent the MSD (page 52).**

**2 Open the vacuum manifold (page 54).**

**3 Open the retaining clip.**

Pinch the two arms of the clip together and swing the clip down.

**4 Remove the electron multiplier horn.**

**5 Install the new electron multiplier horn.**

**6 Close the retaining clip.**

The signal pin on the horn should rest *on the outside* of the loop in the contact strip. **Do not** put the signal pin on the inside of the loop in the contact strip. Incorrect installation will result in poor sensitivity or no signal

**7 Close the vacuum manifold (page 56).**

**8 Pump down the MSD (page 58).**

To replace the electron multiplier horn

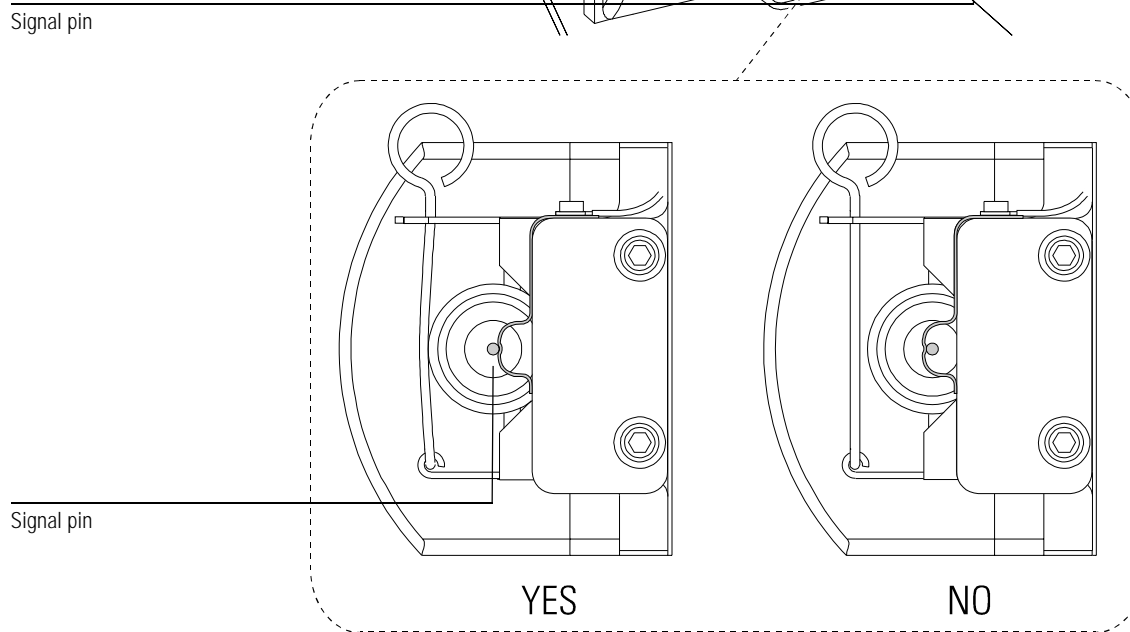
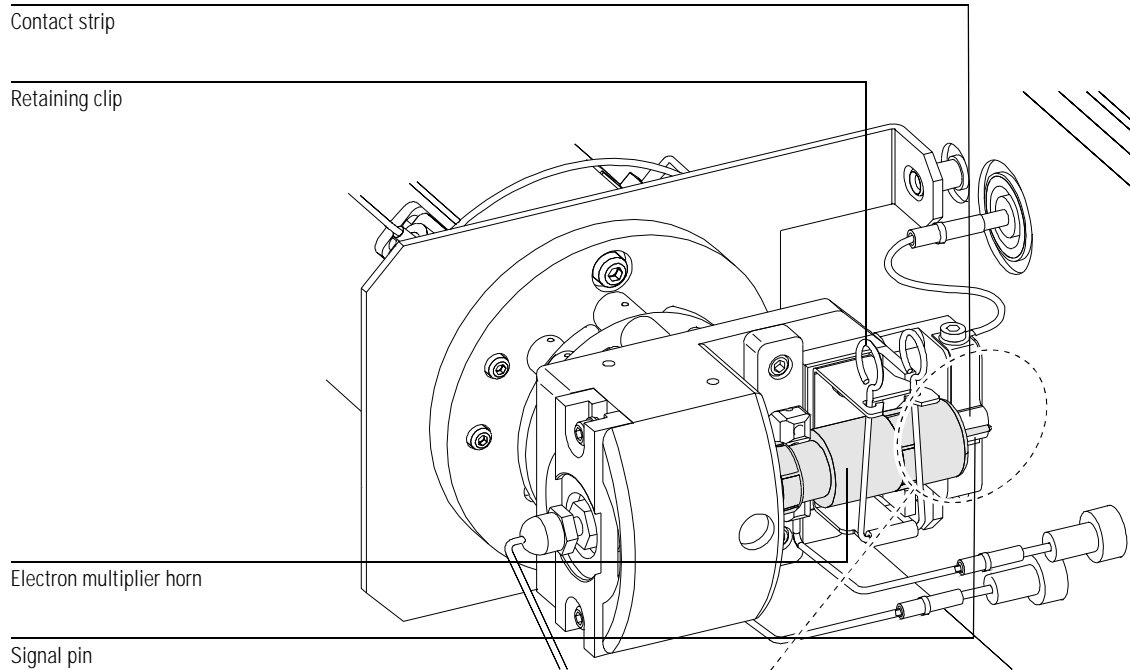

## Maintaining the GC/MSD interface

### ***The GC/MSD interface requires no periodic maintenance***

Rarely, the heater cartridge in the GC/MSD interface fails. In those cases, it is necessary to replace the heater and sensor. This section contains procedures for removing the heater and sensor and installing new ones.

### ***More information is available***

If you need more information about the locations or functions of GC/MSD interface components, refer to Chapter 6, *GC/MSD Interface*, on page 211.

Most of the procedures in this chapter are illustrated with video clips in the HP 5973 MSD Reference Collection CD-ROM.

---

## To remove the GC/MSD interface heater and sensor

*Materials needed:* Screwdriver, TORX T-15 (8710-1622)

**1 Vent the MSD (page 52).**

Make sure you turn off the GC/MSD interface heater. This heater is controlled and powered by the GC.

**2 Separate the MSD from the GC (page 112).**

**3 Remove the cover from the GC/MSD interface.**

---

**W A R N I N G**

---

**The GC/MSD interface operates a very high temperatures. It is also well insulated. Make sure the interface is cool *before* you touch it.**

**4 Slide the insulation off of the GC/MSD interface.**

**5 Loosen the two heater sleeve screws.**

**6 Slide the heater sleeve off of the GC/MSD interface.**

It may be necessary to *gently* pry open the slot in the heater sleeve to loosen the heater sleeve from the interface.

**7 Loosen the setscrew and remove the heater and temperature sensor from the heater sleeve.**

Heat and oxidation often result in a heater, or less frequently a temperature sensor, being “welded” inside the heater sleeve. The holes for the heater and sensor pass all the way through the heater sleeve. A rod can be inserted to drive the stuck part out. However, to function correctly the heater and sensor must have perfect contact with their holes. If a heater or sensor is difficult to remove, the holes will probably be damaged enough that the heater sleeve should be replaced. Polishing the holes is not an acceptable solution since it will enlarge the holes.

---

**C A U T I O N**

---

Installing a new heater and sensor in a damaged heater sleeve will result in poor performance of the heated zone and could reduce the lifetime of the new parts.

---

#### 4 Maintaining the MSD

##### To remove the GC/MSD interface heater and sensor

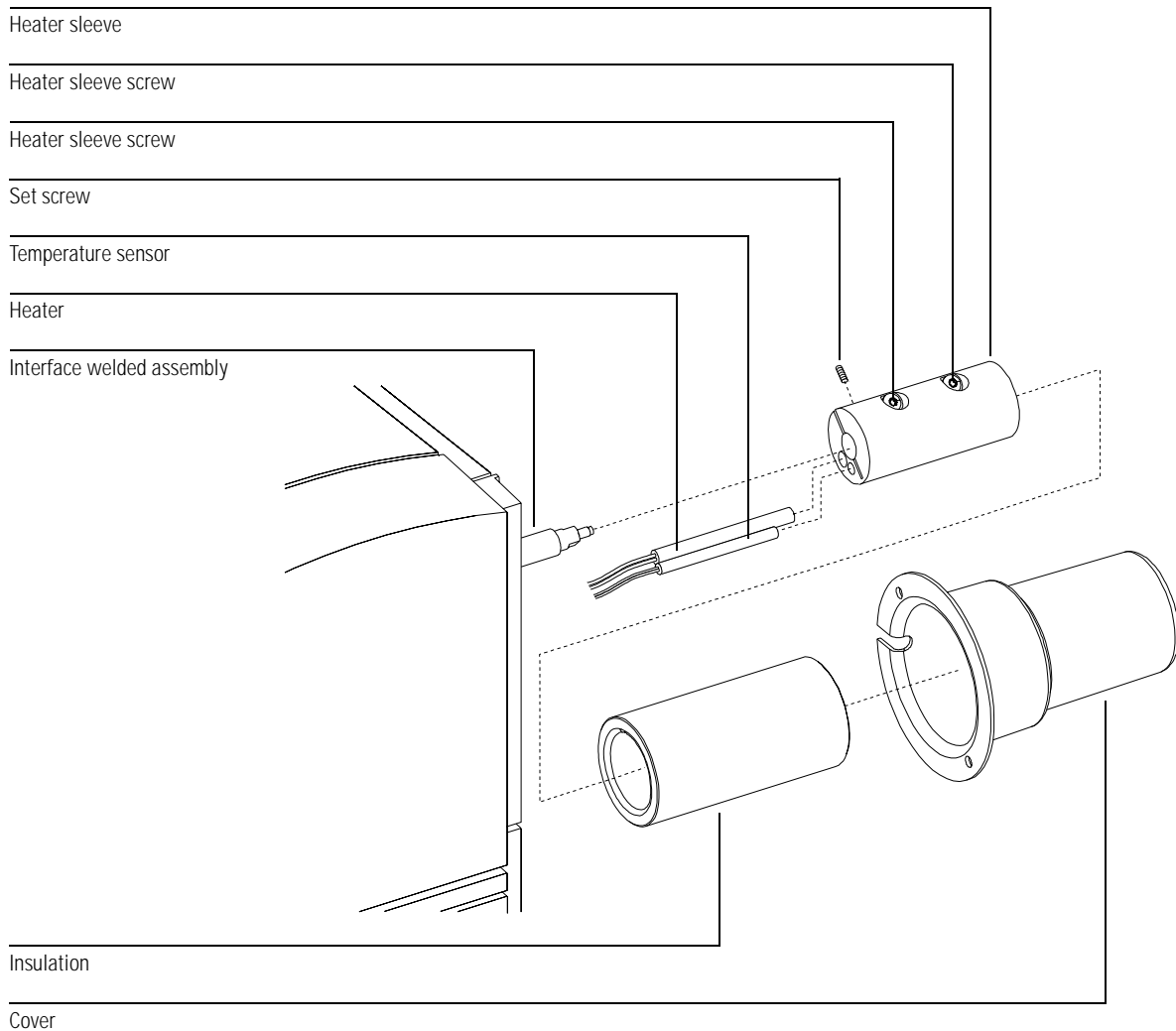

---

## To reinstall the GC/MSD interface heater and sensor

*Materials needed:*

GC/MSD interface heater assembly (05972-60106)  
Heater sleeve (G1099-20210) – replace the old sleeve if it is damaged  
Screwdriver, TORX T-15 (8710-1622)

- 1 Slide the new heater and temperature sensor into the heater sleeve.**
- 2 Reinstall the setscrew.**
- 3 Slide the heater sleeve onto the GC/MSD interface.**  
Align the heater sleeve so the screws are on top. Tighten the screws evenly.
- 4 Slide the insulation onto the GC/MSD interface.**

---

**CAUTION**

There is a shallow groove along the inner surface of the insulation. This groove *must* line up with the heads of the screws in the heater sleeve. If it does not, you can crack or otherwise damage the insulation.

- 5 Reinstall the GC/MSD interface cover.**  
Make sure the wires from the heater and sensor pass through the cutout in the interface cover.
- 6 Reconnect the MSD to the GC (page 120).**  
Make sure you reconnect the GC/MSD interface cable to the GC. Make sure you reinstall the capillary column.
- 7 Pump down the MSD (page 58).**
- 8 Turn on the GC.**  
Re-establish appropriate temperature setpoints for the GC/MSD interface and GC oven.

Heater sleeve

Heater sleeve screw

Heater sleeve screw

Set screw

Temperature sensor

Heater

Interface welded assembly

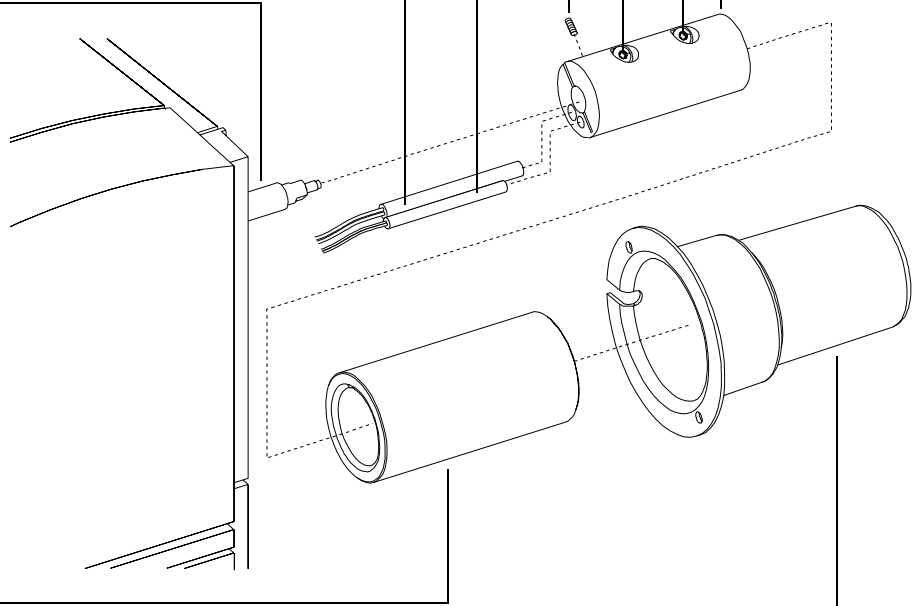

Insulation

Cover

---

# Maintaining the electronics

## ***The MSD electronics do not require any scheduled maintenance***

None of the electronic components of the MSD need to be replaced on a regular schedule. None of the electronic components in the MSD need to be adjusted or calibrated on a regular schedule. Avoid unnecessary handling of the MSD electronics.

## ***Very few of the electronic components are operator serviceable***

The primary fuses can be replaced by the operator. The RF coils can be adjusted by the operator. All other maintenance of the electronics should be performed by your Hewlett-Packard service representative.

---

### **W A R N I N G**

---

**Improper use of these procedures could create a serious safety hazard. Improper use of these procedures could also result in serious damage to, or incorrect operation of, the MSD.**

---

### **W A R N I N G**

---

**Vent the MSD and disconnect its power cord before performing any of these procedures *except* adjusting the RF coils.**

## ***Electrostatic discharge is a threat to the MSD electronics during maintenance***

All of the printed circuit boards in the MSD contain components that can be damaged by electrostatic discharge (ESD). Do not handle or touch these boards unless absolutely necessary. In addition, wires, contacts, and cables can conduct ESD to the printed circuit boards to which they are connected. This is especially true of the mass filter (quadrupole) contact wires which can carry ESD to sensitive components on the side board. ESD damage may not cause immediate failure but it will gradually degrade the performance and stability of your MSD.

**To reinstall the GC/MSD interface heater and sensor**

When you work on or near printed circuit boards, or when you work on components with wires, contacts, or cables connected to printed circuit boards, always use a grounded anti-static wrist strap and take other anti-static precautions. The wrist strap should be connected to a known good Earth ground. If that is not possible, it should be connected to a conductive (metal) part of the assembly being worked on, but **not** to electronic components, exposed wires or traces, or pins on connectors.

Take extra precautions, such as a grounded, anti-static mat, if you must work on components or assemblies that have been removed from the MSD. This includes the analyzer.

---

**C A U T I O N**

---

In order to be effective, an anti-static wrist strap must fit snugly (not tight). A loose strap provides little or no protection.

---

**C A U T I O N**

---

Anti-static precautions are not 100% effective. Handle electronic circuit boards as little as possible, and then only by the edges. Never touch the components, exposed traces, or pins on connectors and cables.

***More information is available***

If you need more information about the functions of electronic components, refer to Chapter 8, *Electronics*, on page 233.

Most of the procedures in this chapter are illustrated with video clips in the HP 5973 MSD Reference Collection CD-ROM.

## To adjust the RF coils

*Materials needed:* Screwdriver, flat-blade, large (8730-0002)

**1 Make sure the MSD is at thermal equilibrium.**

It takes at least 2 hours *after* all heated zones have reached their setpoints for the MSD to reach thermal equilibrium.

**2 Remove the upper MSD cover (page 50).**

---

**W A R N I N G**

---

**Do not remove the side board cover, the RF cover, or any other covers. Dangerous voltages are present under these covers.**

**3 Make sure the RF cover is secure and no screws are missing.**

A loose RF cover or missing screw can *significantly* affect coil adjustment.

**4 In the Diagnostics/Vacuum Control view, select Set RFPA from the Diagnostics menu.**

**5 Enter an amu value of 100.**

**6 Slowly turn the RF coil adjustment screws to minimize the voltage displayed.**

Turn the adjustment screws alternately. Turn each screw only a little bit at a time. Keep the screws at *equal* extension. The minimum voltage is typically between 70 and 100 mV.

---

**C A U T I O N**

---

Do not use a coin to adjust the RF coils. If you drop it, it could fall into the electronics fan and cause significant damage.

**7 When the voltage is minimized, click the Stop button.**

#### 4 Maintaining the MSD

##### To adjust the RF coils

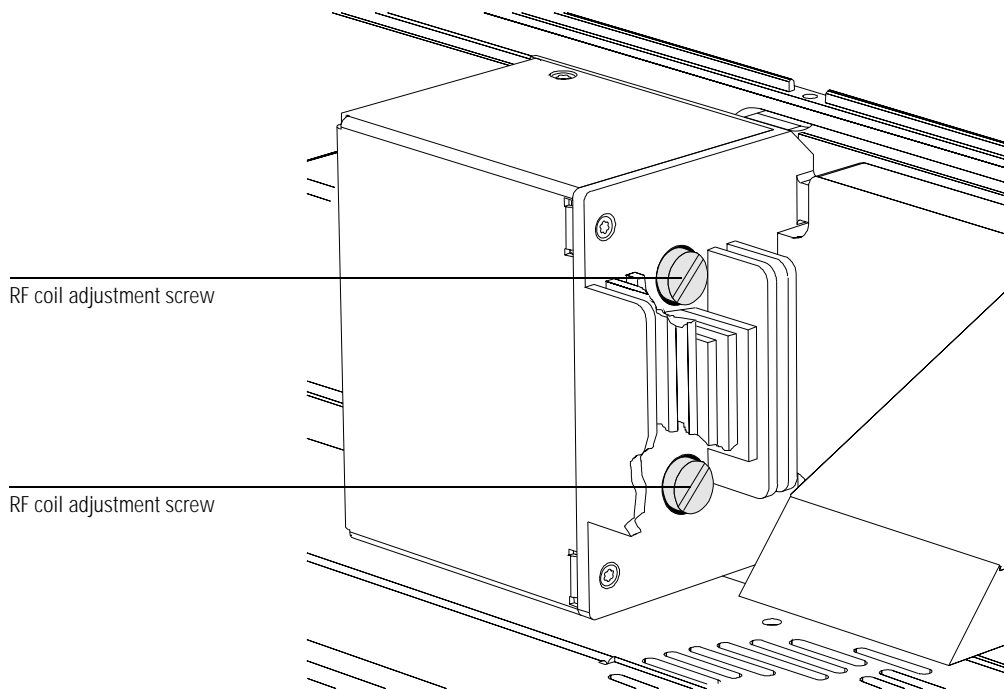

**8 Repeat steps 4 through 7 for 650 amu.**

The minimum voltage is typically between 500 and 650 mV.

**9 Exit the Set RFPA program.**

**10 Select MS OFF from the Diagnostics menu.**

**11 Reinstall the upper MSD cover.**

**12 Tune the MSD (page 48).**

---

## To replace the primary fuses

*Materials needed:*

Fuse, T8 A, 250 V (2110-0969) – 2 required  
Screwdriver, flat-blade (8730-0002)

The most likely cause of failure of the primary fuses is a problem with the foreline pump. If the primary fuses in your MSD fail, check the foreline pump.

**1 Switch off the MSD and unplug the power cord from the electrical outlet.**

If one of the primary fuses has failed, the MSD will already be off, but for safety you should switch off the MSD and unplug the power cord.

---

**W A R N I N G**

---

**Never replace the primary fuses while the MSD is connected to a power source.**

---

**C A U T I O N**

---

If a fuse failure turns off the MSD, wait at least 30 minutes before venting the instrument. Venting sooner could cause a diffusion pump to backstream or could damage a turbomolecular pump.

**2 Vent the vacuum manifold by opening the vent valve knob.**

---

**W A R N I N G**

---

**If you are using hydrogen as a GC carrier gas, a power failure may allow it to accumulate in the vacuum manifold. In that case, further precautions are required. See the *Hydrogen Carrier Gas Safety Guide* (5995-5398).**

**3 Turn one of the fuse holders counterclockwise until it pops out.**

The fuse holders are spring loaded.

**4 Remove the old fuse from the fuse holder.**

**5 Install a new fuse in the fuse holder.**

**6 Reinstall the fuse holder.**

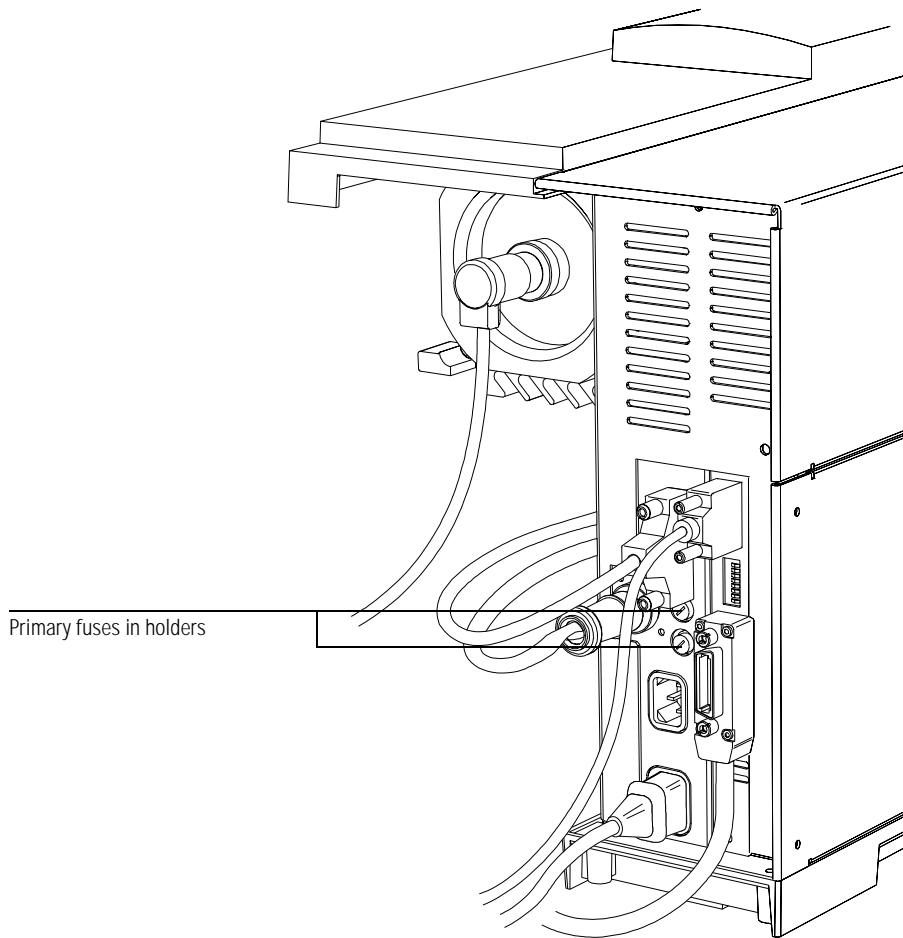

**7 Repeat steps 3 - 6 for the other fuse.**

Always replace both fuses.

**8 Reconnect the MSD power cord to the electrical outlet.**

**9 Pump down the MSD (page 58).**

Diffusion pump MSD vacuum system, 186  
Turbo pump MSD vacuum system, 187  
Diffusion pump vacuum manifold, 188  
Turbo pump vacuum manifold, 189  
Side plate, 190  
Vacuum seals, 192  
Foreline pump, 194  
Foreline gauge, 196  
Diffusion pump and fan, 198  
Turbomolecular pump and fan, 202  
Calibration valve and vent valve, 204  
Triode gauge tube, 206  
Gauge controller, 208

---

## Vacuum System

This chapter describes components of the vacuum system in the MSD

---

# Vacuum System

## ***The vacuum system is essential to MSD operation***

The vacuum system creates the high vacuum (low pressure) required for the MSD to operate. Without the vacuum, the molecular mean free path would be too short. Ions would collide with air molecules before they could reach the detector. Operation at high pressures would damage analyzer components.

The HP 5973 MSD has one of two kinds of vacuum system: diffusion pump (HP G1098A) or turbomolecular (turbo) pump (HP G1099A). Many parts of the vacuum system are common to both, but some parts are specific to the one high vacuum pump or the other.

## ***Many components make up the vacuum system***

Many parts make up the vacuum system:

- Vacuum manifold
- Side plate, and front and rear end plates
- Vacuum seals
- Foreline (rough) pump
- High vacuum pump
- Calibration valve and vent valve
- Vacuum control electronics
- Vacuum gauges and gauge control electronics

Each of these is discussed in more detail in the following material.

## ***Vacuum system control is mostly automated***

Most vacuum system operation is automated. Operator interaction is through the data system. Monitoring of the vacuum system is done through the data system and through the optional gauge controller.

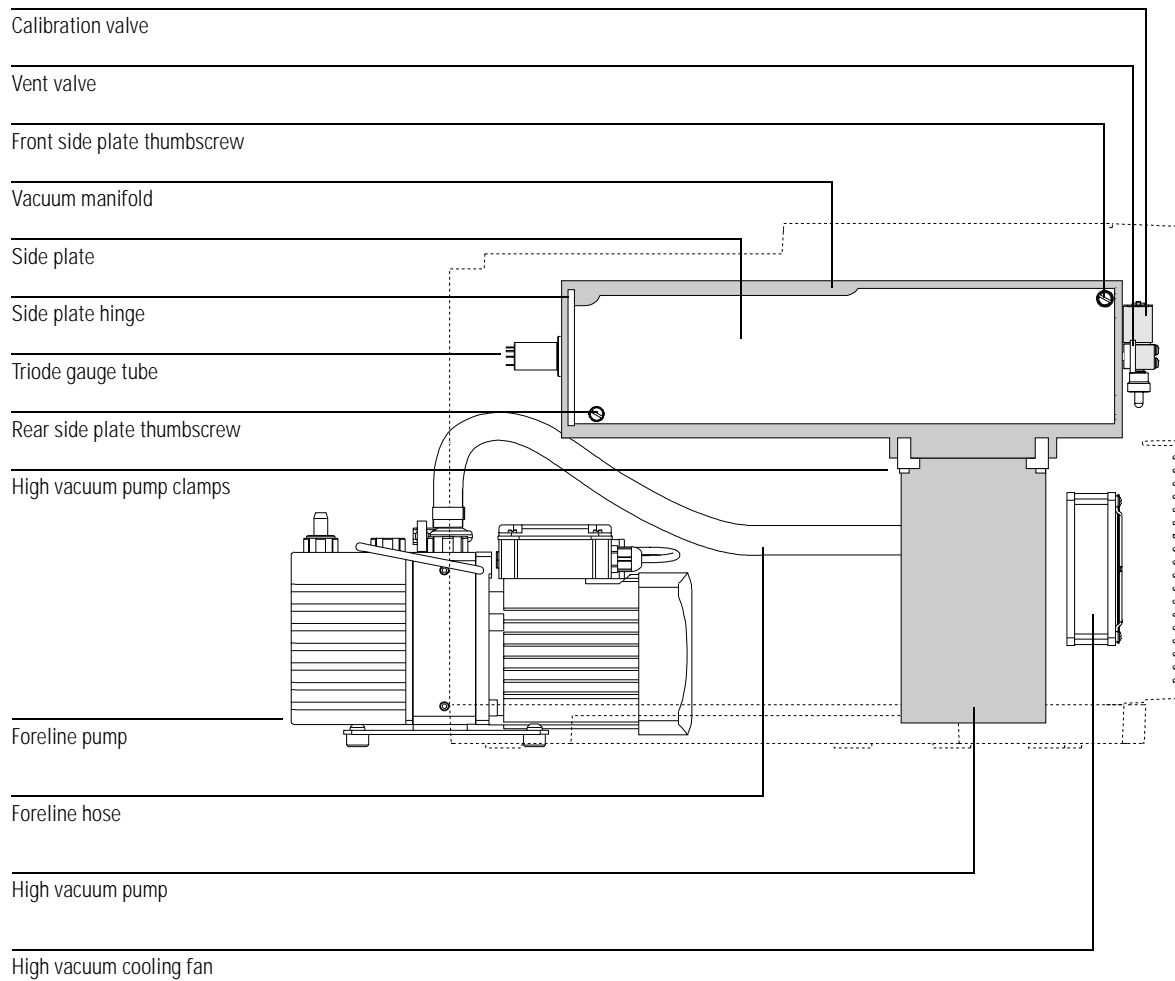

## Diffusion pump MSD vacuum system

## Diffusion pump MSD vacuum system

The high vacuum pump in the HP G1098A model of the MSD is a vapor diffusion pump. A diffusion pump requires baffling to prevent vapor from migrating into the vacuum manifold. Foreline pressure is monitored by the foreline gauge. The ac board controls the diffusion pump heater. The diffusion pump MSD can accept up to 2 ml/min carrier gas flow.

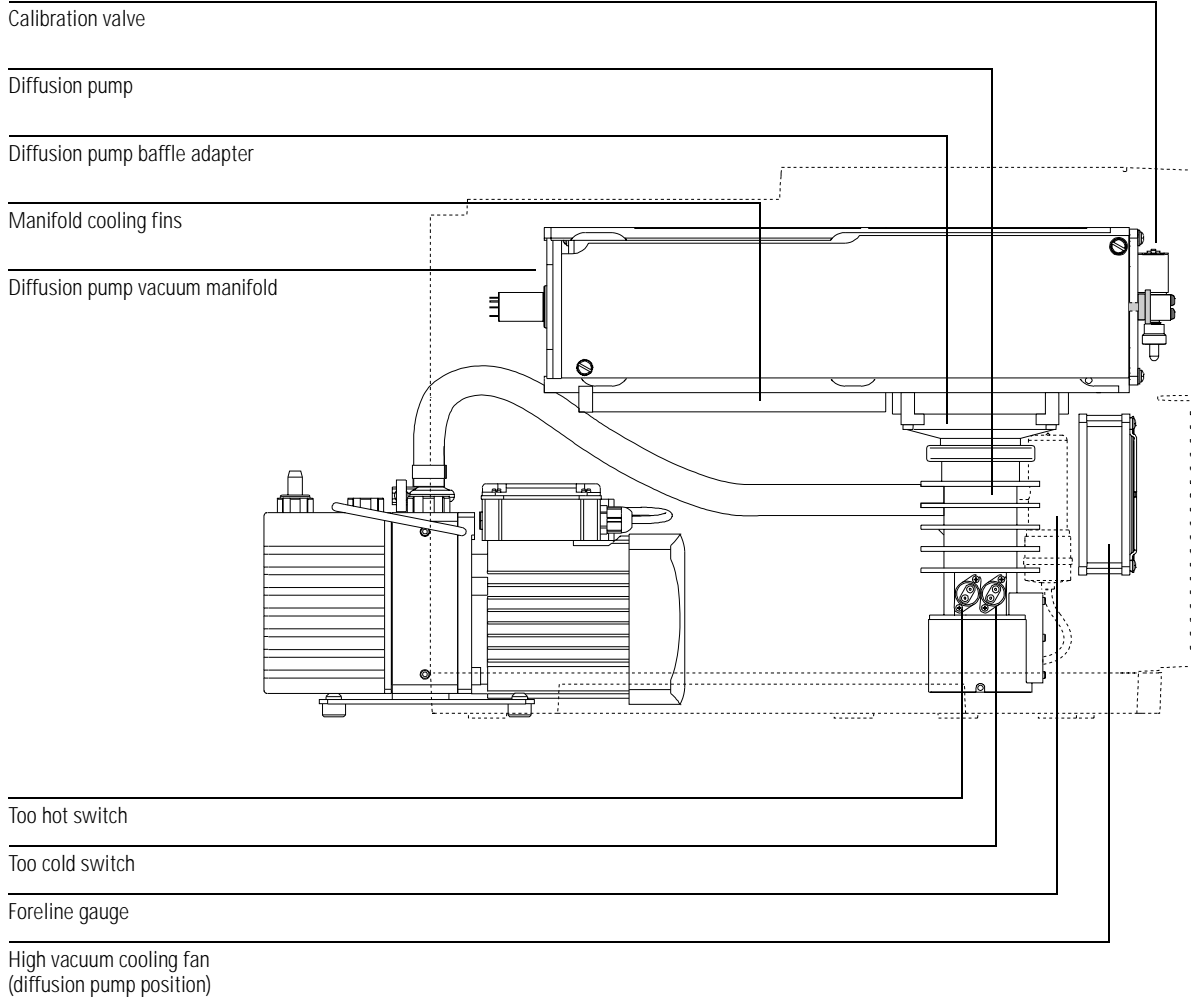

## Turbo pump MSD vacuum system

The high vacuum pump in the HP G1099A model of the MSD is a turbomolecular (turbo) pump. A turbo pump requires a screen to keep debris out of the pump, but no baffle is necessary. Pump speed is controlled by the turbo controller; there is no foreline gauge. The turbo pump MSD can accept up to 4 ml/min carrier gas flow. The calibration valve has a restrictor with a larger internal diameter.

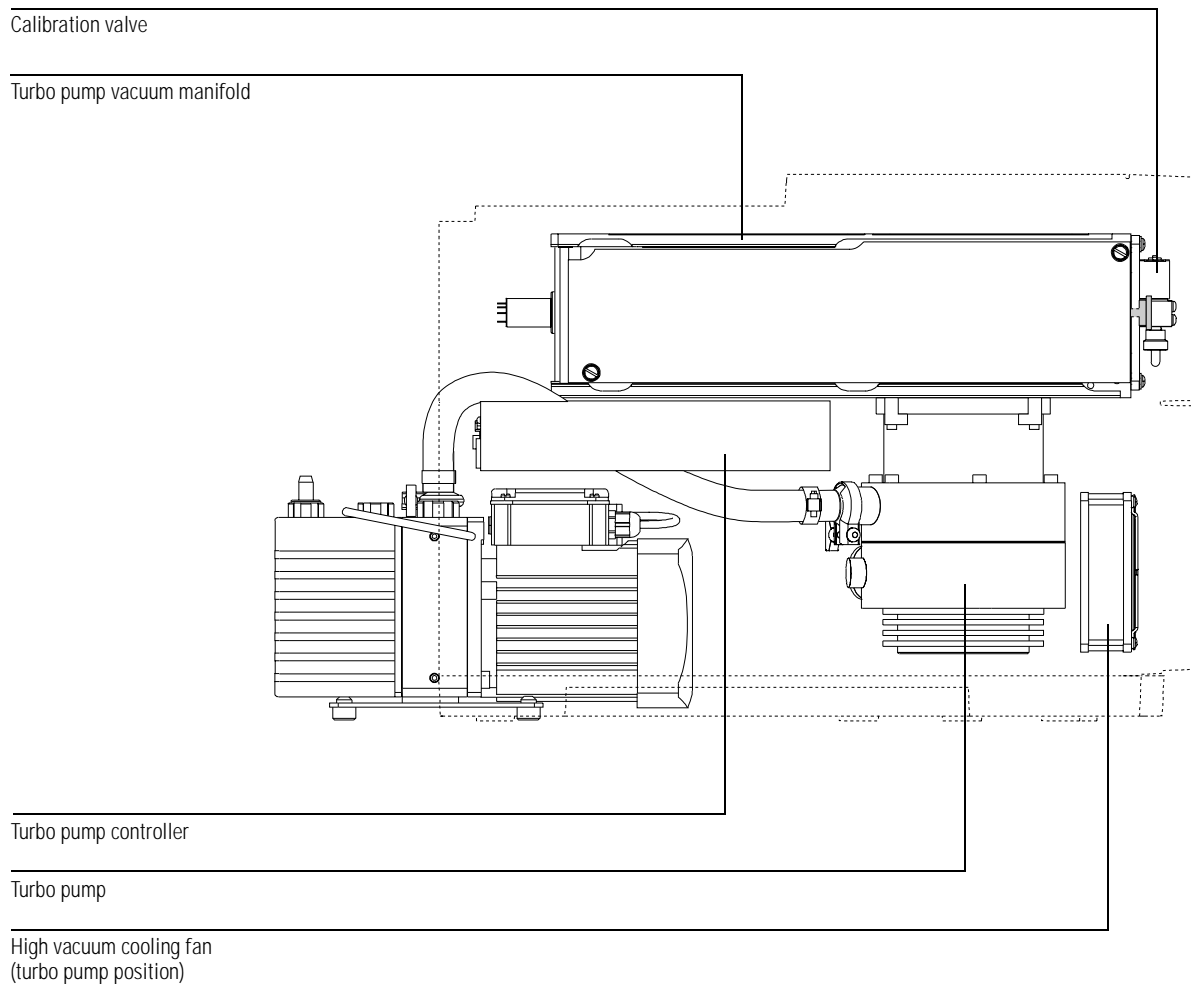

**Diffusion pump vacuum manifold****Diffusion pump vacuum manifold**

The vacuum manifold is the chamber in which the analyzer operates. The manifold is extruded and machined from an aluminum alloy. Large openings in the side, front, and rear of the vacuum manifold are closed by plates. O-rings provide the seals between the plates and the manifold. Ports in the manifold and the plates provide attachment points for the triode gauge tube, calibration valve, vent valve, GC/MSD interface, and high vacuum pump.

The diffusion pump attaches with a KF50 seal to a baffle adapter that is clamped to the bottom of the manifold. A vapor baffle helps prevent migration of pump fluid vapor into the manifold. Cooling fins on the bottom of the manifold keep the baffle cool so the vapor will condense on it.

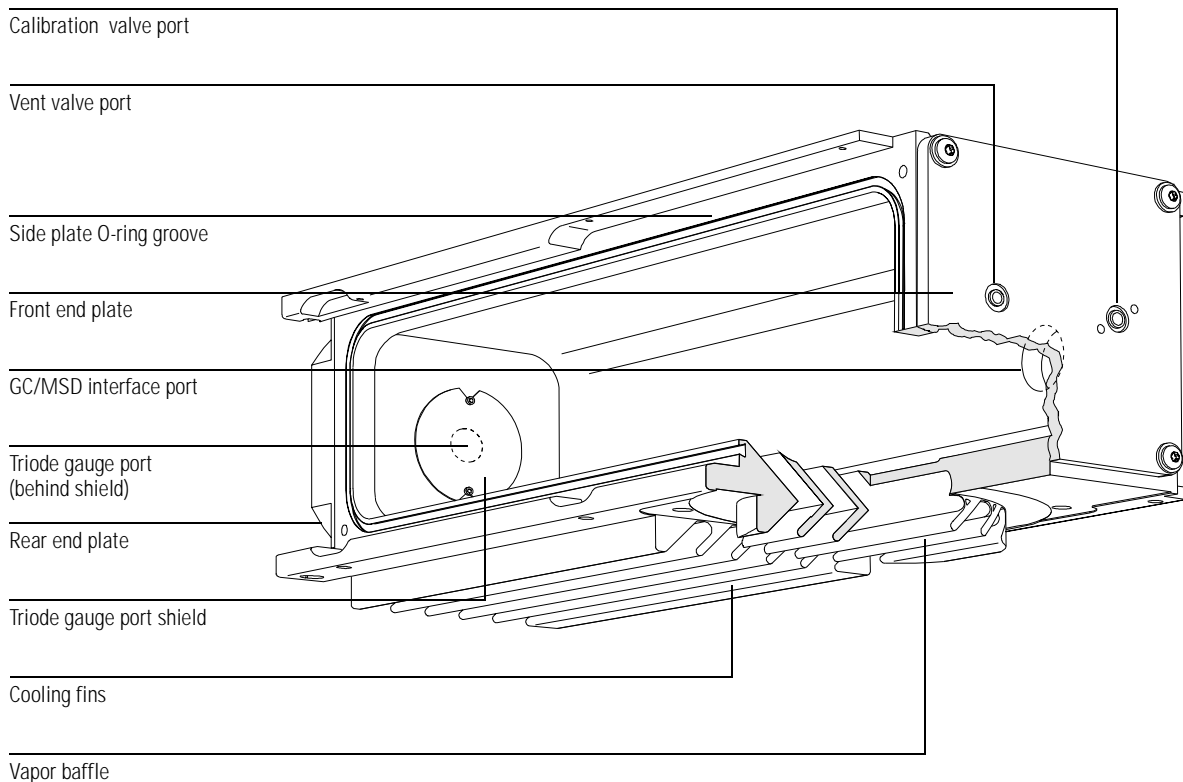

---

## Turbo pump vacuum manifold

The manifold for the turbo pump does not have a baffle or cooling fins. The turbo pump and the mounting bracket for the turbo controller are clamped directly to the manifold.

In every other respect, the two manifolds are identical.

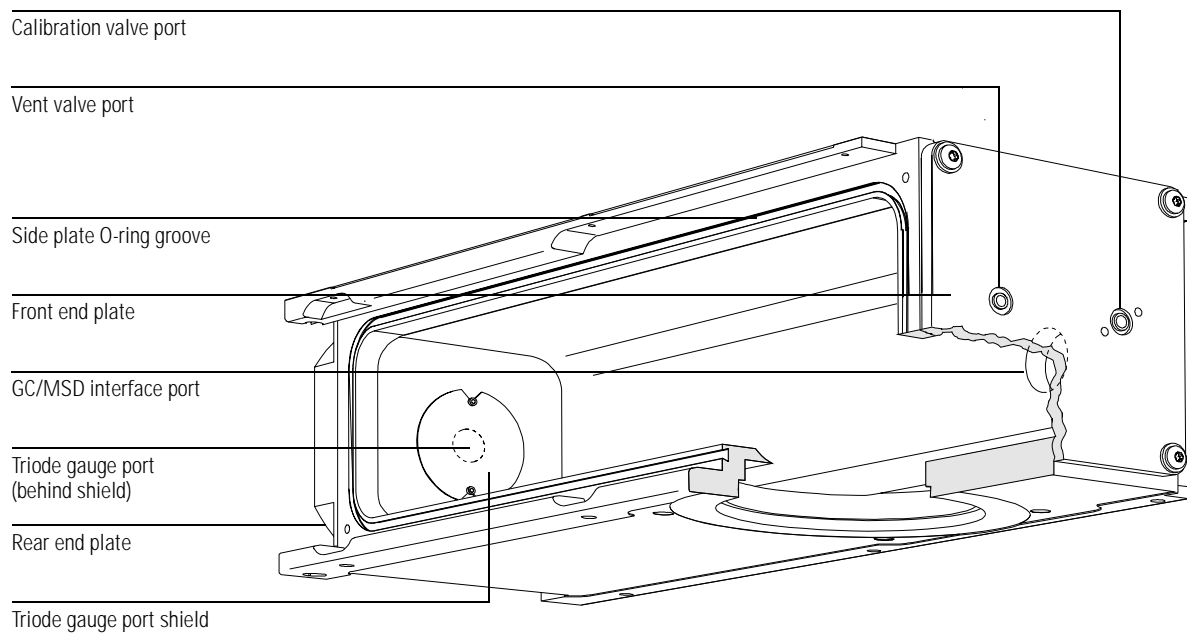

**Side plate**

---

## Side plate

The side plate is a flat stainless steel plate that covers the large opening in the side of the vacuum manifold. The side plate is attached to the manifold with a hinge. The analyzer assembly is attached to the side plate inside the vacuum manifold. The hinge allows the side plate to swing away from the manifold for easy access to the analyzer.

Several electrical feedthroughs are built into the side plate. Wires connect the feedthroughs to analyzer components. The electronic side board is mounted on the atmospheric side of the side plate.

Thumbscrews are located at each end of the side plate.

---

**CAUTION**

Fasten both side plate thumbscrews for shipping or storage **only**. For normal operation the both thumbscrews should be loose. For operation with hydrogen carrier gas, or with flammable or explosive CI reagent gases, the front thumbscrew should be fastened just finger tight. Overtightening will warp the side plate and cause air leaks. **Do not** use a tool to tighten the side plate thumbscrews.

---

**CAUTION**

When you turn on the power to pump down the MSD, be sure to press on the sideplate to ensure a good seal.

---

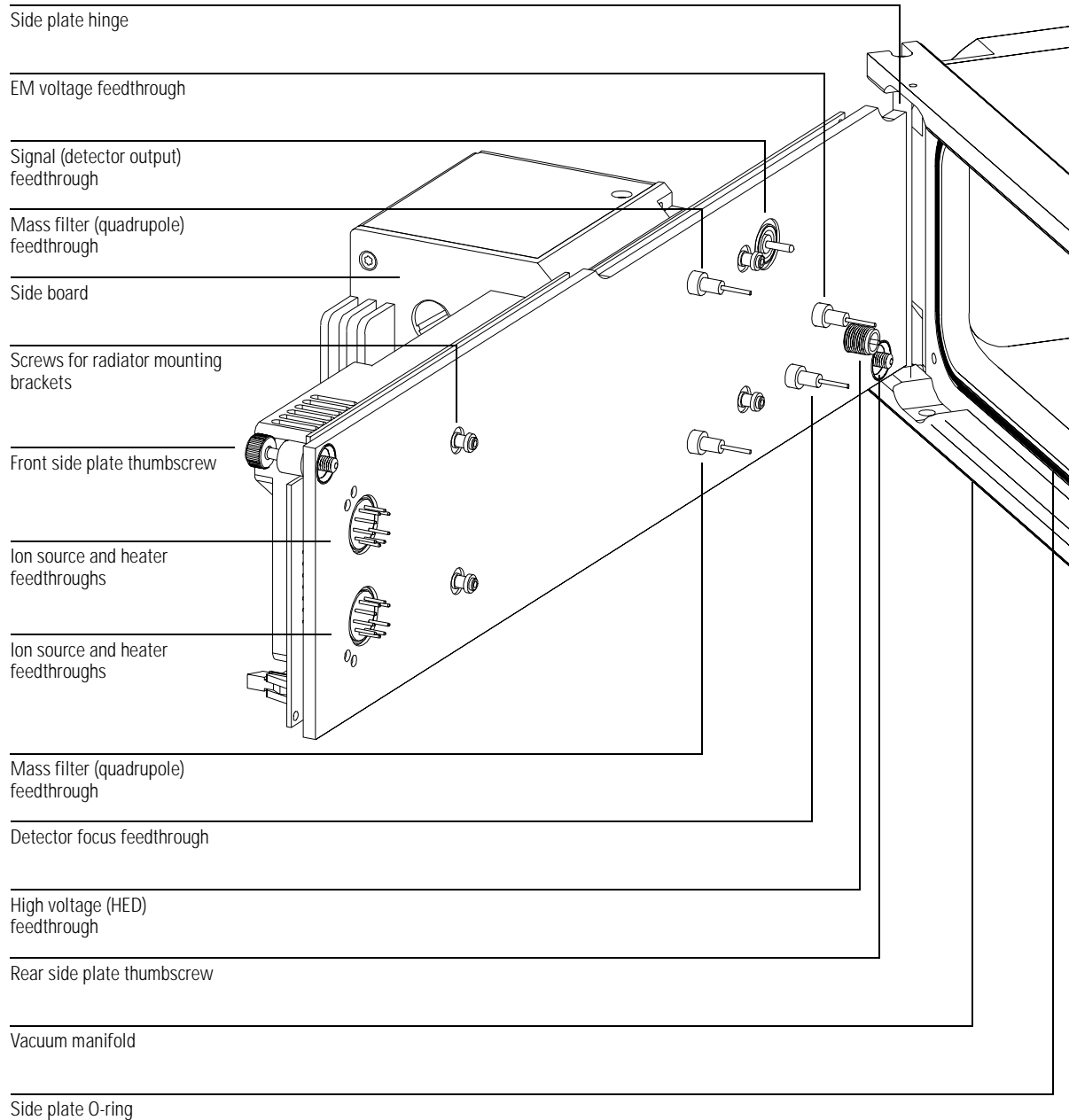

## Vacuum seals

Several types of Viton elastomer O-ring seals are used to prevent air leaks into the vacuum manifold. All these O-rings, and the surfaces to which they must seal, must be kept clean and protected from nicks and scratches. A single hair, piece of lint, or scratch can produce a serious vacuum leak. Two of the O-rings are *lightly* lubricated with Apiezon-L vacuum grease: the side plate O-ring and the vent valve O-ring.

### Face seals

A face seal is an O-ring that fits in a shallow groove. The sealing surface is usually a flat plate. The manifold side plate and end plate O-rings fit into grooves around the large openings in the vacuum manifold. The side plate swings into place against the side plate O-ring, and must be held in place when the MSD is turned on for pumpdown in order to assure a good seal.

The front and rear end plates are screwed onto the manifold, and should not need to be removed. The GC/MSD interface fastens to the manifold with three screws.

The calibration valve assembly is fastened onto the front end plate by two screws. The vent valve knob threads into the front end plate. Small O-rings in grooves in the front end plate provide vacuum seals.

The diffusion pump baffle adapter has a groove for its O-ring. The baffle adapter is clamped to the manifold with 4 claw grips.

### KF (NW) seals

Most of the seals for the high vacuum pumps, foreline gauge, and foreline pump are KF seals. KF seals have an O-ring supported by a centering ring. The centering ring can be either on the inside or the outside of the O-ring. The clamp presses two flanges against the O-ring, making a seal. KF clamps must not be overtightened.

### Compression seals

A compression fitting consists of a threaded fitting on the vacuum manifold and a threaded collar with a ferrule and O-ring. A cylindrical part fits inside the collar. Tightening the collar presses the ferrule, compressing the O-ring around the part. The triode gauge tube and calibration vial use compression seals.

---

### High voltage feedthrough seal

The high voltage (HED) feedthrough seal is an O-ring that is compressed against the side plate by a threaded collar.

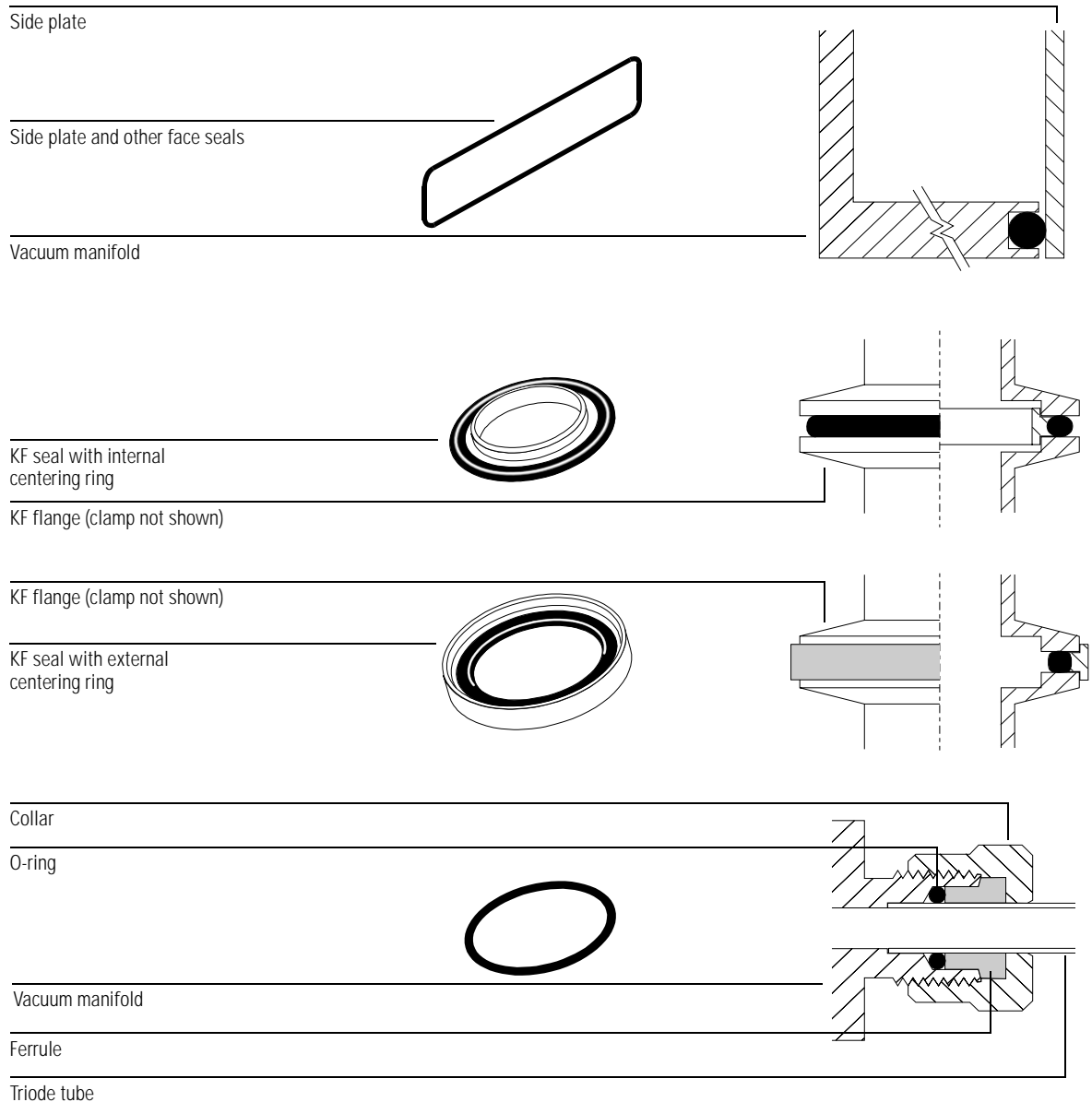

## Foreline pump

The foreline pump reduces the pressure in the vacuum manifold so the high vacuum pump can operate. It also pumps away the gas load from the high vacuum pump. The foreline pump is connected to the high vacuum pump by a 130-cm hose called the foreline hose.

The foreline pump is a two-stage rotary-vane pump. The foreline pump turns on when the MSD power is turned on. The foreline pump has a built-in anti-suckback valve to help prevent backstreaming in the event of a power failure.

The foreline pump can be placed under the vacuum manifold at the rear of the MSD (with the exhaust outlet to the rear), or on the floor below the MSD.

The MSD shipping kit includes an oil trap (not shown) that can be used to filter pump oil out of the foreline pump exhaust. This trap stops **only** pump oil. If you are analyzing toxic chemicals or using toxic solvents, do not use the trap. Instead, install a hose to take the foreline pump exhaust outside or to a fume hood.

---

### WARNING

**The foreline pump exhaust contains traces of solvents, analytes, and foreline pump oil. The supplied oil trap stops only pump oil. It does not trap or filter out toxic chemicals. If you are using toxic solvents or analyzing toxic chemicals, remove the oil trap and install a hose to take the foreline pump exhaust outside or to a fume hood.**

---

### CAUTION

Do not place the foreline pump near any equipment that is sensitive to vibration.

---

### CAUTION

The ballast control knob controls the amount of air allowed into the pump. Keep the ballast control closed (fully clockwise) at all times.

A window (sight glass) in the front of the foreline pump shows the level of the foreline pump oil. There are two marks next to the window. The level of the pump oil should never be above the upper mark or below the lower mark. If the level of pump oil is near the lower mark, add foreline pump oil.

### See Also

*To check and add foreline pump oil, page 102*

---

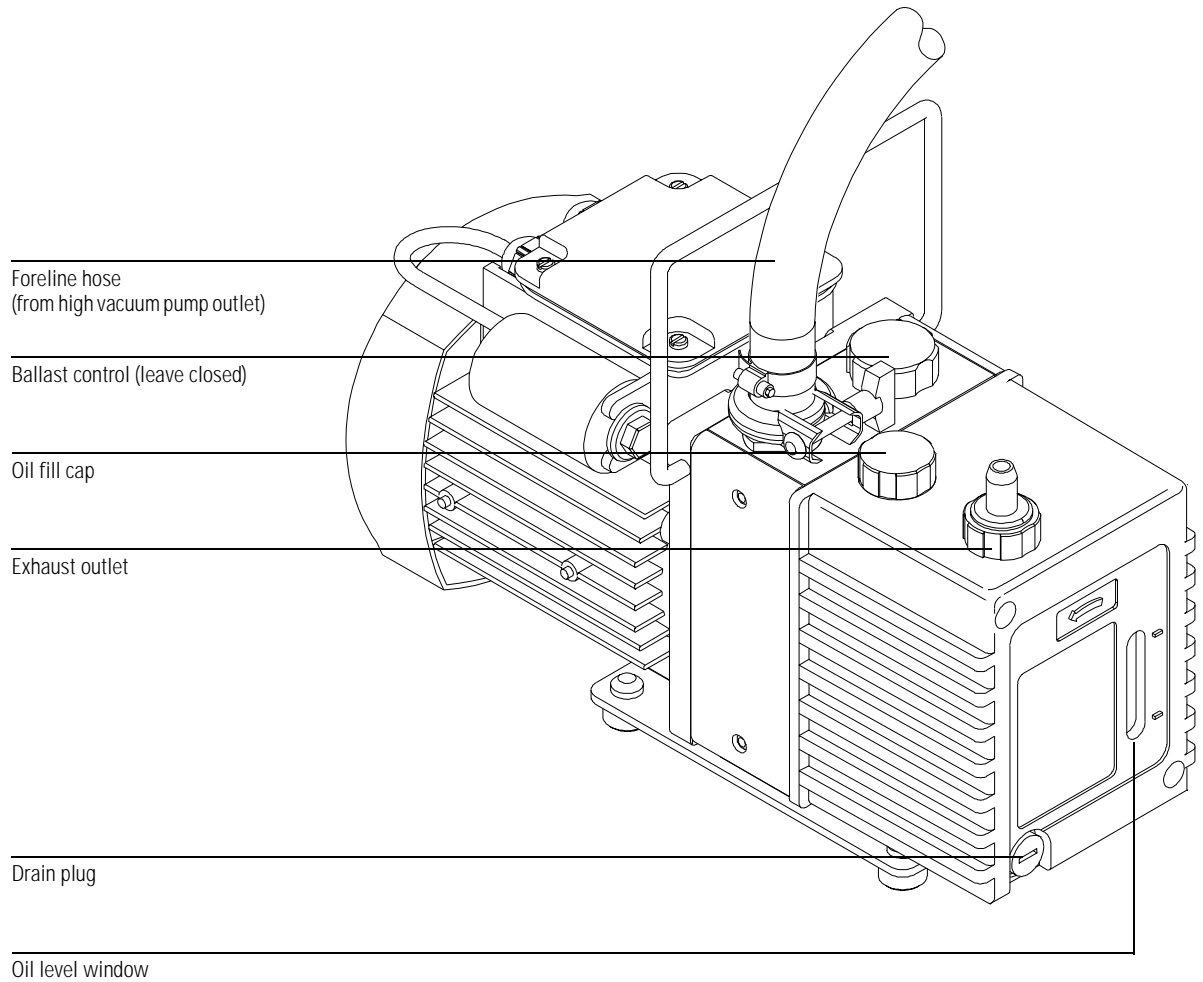

## Foreline gauge

The foreline gauge monitors the pressure (vacuum) at the exit of the diffusion pump. The primary function of the foreline gauge is diffusion pump control. When the foreline pump has reduced the pressure in the vacuum manifold to below

300 mTorr (0.3 Torr), the diffusion pump is automatically switched on. If the foreline pressure rises above 400 mTorr (0.4 Torr), the ac board switches off the diffusion pump heater and the analyzer electronics.

The foreline pressure can be monitored from your data system.

The turbo pump MSD does not require a foreline gauge. Instead, the motor speed is monitored.

### See Also

*To view MSD temperature and vacuum status, page 36*

*Gauge controller, page 208*

*Table 2. Typical MSD pressure readings for various carrier gas flow rates, page 45*

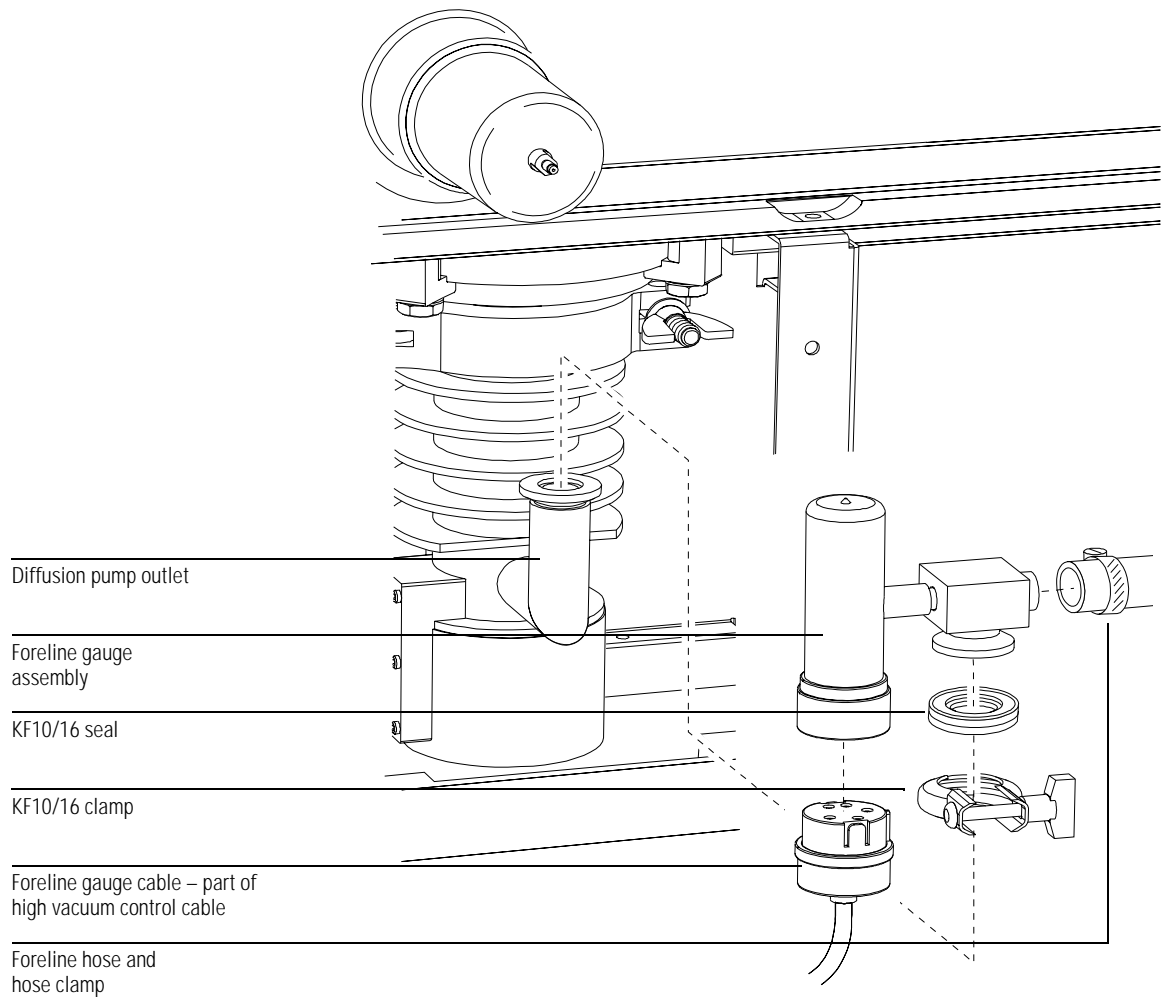

## Diffusion pump and fan

The diffusion pump creates the low pressure (high vacuum) required for correct analyzer operation. The diffusion pump in the MSD is an air-cooled vapor diffusion pump with 90 liters/second capacity. It mounts with a KF50 fitting to a baffle adapter clamped to the bottom of the vacuum manifold.

The diffusion pump has a cylindrical body surrounded by fins to help dissipate heat. Its inlet is open to the interior of the vacuum manifold, through the adapter and baffle. A structure called the stack is located at the center of the pump body. An electric heater is located at the bottom of the stack.

The diffusion pump transports gas by momentum transfer. The heater boils a special fluid (a polyphenyl ether) inside the stack. As the vapor pressure increases, the pump fluid vapor is forced out and downward through nozzles in the stack. The vapor forced out of these nozzles strikes the gas molecules that are present. This forces the gas molecules down toward the outlet near the bottom of the pump. Another nozzle in the stack points directly at the outlet and forces the gas molecules out. The vapor condenses on the sides of the pump and the liquid drains down to the bottom. The liquid is boiled again and is reused continuously.

The foreline pump is connected by the foreline hose to the outlet of the diffusion pump. It removes the gas molecules that reach the outlet.

The diffusion pump operation is controlled by the ac board. The ac board turns on the diffusion pump heater automatically as soon as the foreline pump lowers the pressure in the vacuum manifold below approximately 300 mTorr (0.3 Torr). If the foreline pressure rises above 400 mTorr, the ac board shuts off the heater. The ac board allows the analyzer electronics to turn on when the diffusion pump is hot.

The diffusion pump typically maintains an indicated pressure below  $1.4 \times 10^{-4}$  Torr for GC helium carrier gas flows up to 2 ml/minute. High vacuum (manifold) pressure can only be measured if your MSD is equipped with the optional gauge controller.

### See Also

*Gauge controller*, page 208

*Table 2. Typical MSD pressure readings for various carrier gas flow rates*, page 198

---

The small size of the diffusion pump allows it to heat up and cool down quickly. This simplifies pumpdown and venting. From initial power-on, the system can pump down to operating pressure in approximately 15 minutes. If the power fails, the diffusion pump fluid stops boiling before the vacuum manifold pressure begins to rise significantly. This helps prevent backstreaming of diffusion pump fluid into the vacuum manifold. Your data system has pumpdown and venting programs to guide you through these procedures. Follow their instructions carefully.

**See Also**

*To pump down the MSD, page 58*

*To vent the MSD, page 52*

A cooling fan is located between the diffusion pump and the front cover of the MSD. The fan draws air through the cover and blows it over the pump. Without this cooling, the pump fluid vapor would not condense correctly, but would diffuse into the vacuum manifold.

Diffusion pump operational readiness is monitored by two thermal switches.

**Table 7**

<b>Diffusion pump thermal switches</b>		
<b>Thermal Switch</b>	Too Cold	Too Hot
<b>Normal state</b>	Normally open	Normally closed
<b>Changes at</b>	170°C rising; 140°C falling	365°C rising
<b>Function</b>	Keeps analyzer turned off until the pump is hot enough to for adequate vacuum. Prevents analyzer damage.	Shuts off diffusion pump and analyzer if the pump overheats. Prevents damage to the pump and analyzer.
<b>Message</b>	The high vacuum pump is not ready	Difficulty with the high vacuum pump
<b>What it means</b>	Normal during pumpdown.	<i>Always</i> indicates a problem.
<b>What to do</b>	Wait for pump to heat up.	Check for fan failure. Make sure pump is cool, and power-cycle MSD to reset.

### Diffusion pump and fan

You can check the condition and level of the diffusion pump fluid through the window (sight glass) near the base of the front of the pump. If the level drops below the appropriate **MIN** marker (there are separate lines for hot and cold conditions) or if the fluid turns dark brown or black, replace the fluid.

Diffusion pump fluid that is exposed to air at operating temperature will break down and turn dark brown or black. This reaction is called cracking. Cracked pump fluid gives two symptoms: higher manifold pressure and high background with a large peak at  $m/z$  446.

#### See Also

*Maintaining the MSD*, page 93

*Troubleshooting (HP 5973 MSD)* in the online help for information on troubleshooting air leaks and other vacuum problems

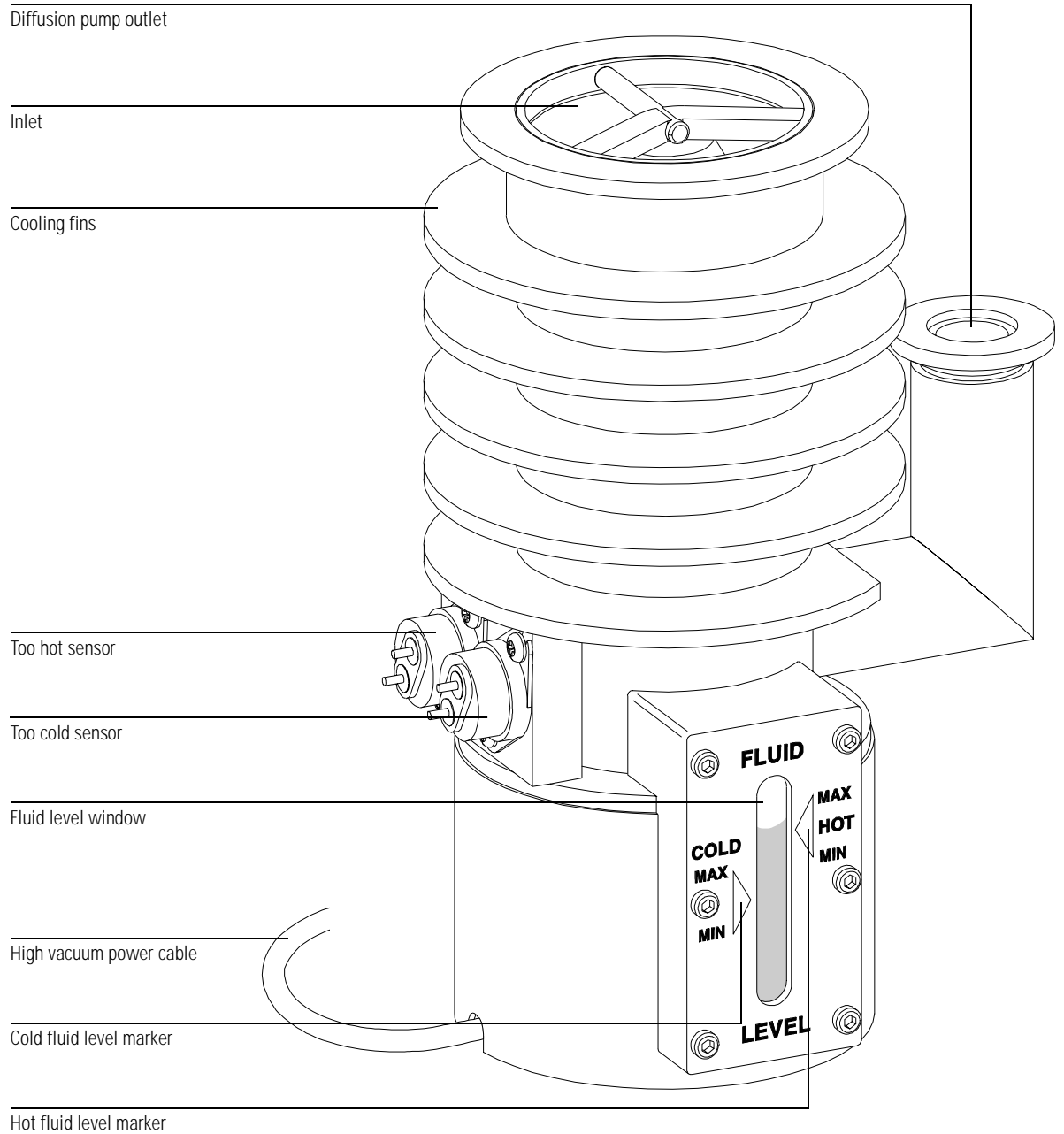

## Turbomolecular pump and fan

The 250 liters/second turbomolecular (turbo) pump creates the low pressure (high vacuum) required for correct analyzer operation. The turbo pump in the MSD is clamped directly to the bottom of the vacuum manifold.

The turbo pump has a cylindrical body with its inlet open to the interior of the vacuum manifold. Inside the pump body is a central shaft or cylinder. Sets of small blades (airfoils) radiate from the central shaft, which spins at up to 60,000 revolutions per minute.

The turbo pump transports gas by momentum transfer. The turbine blades are angled so that when they strike a gas molecule it is deflected downward. Each set of blades pushes the gas molecules further down toward the pump outlet. The foreline pump is connected by a hose to the outlet of the turbo pump. It removes the gas molecules that reach the outlet.

A separate controller regulates current to the pump and monitors pump motor speed and temperature. A cooling fan is located between the turbo pump and the front panel of the MSD. The fan draws air from outside the MSD and blows it over the pump.

The turbo pump turns on automatically as soon as the MSD power is switched on. The system will allow the analyzer to be turned on when the turbo pump is greater than 80% speed, but the pump normally operates at 100% speed. The turbo pump typically maintains an indicated pressure below  $7 \times 10^{-5}$  Torr for GC carrier gas flows up to 4 ml/minute. Pressure (vacuum) can only be measured if your MSD is equipped with the optional gauge controller.

The turbo pump spins up (starts) and spins down (stops) quickly. This simplifies pumpdown and venting. From initial power-on, the system can pump down to operating pressure in 5 to 10 minutes.

The MSD ChemStation has pumpdown and venting programs to guide you through these procedures. Follow their instructions carefully.

### See Also

*Gauge controller*, page 208

*To pump down the MSD*, page 58

*To vent the MSD*, page 52

*Table 2. Typical MSD pressure readings for various carrier gas flow rates*, page 45

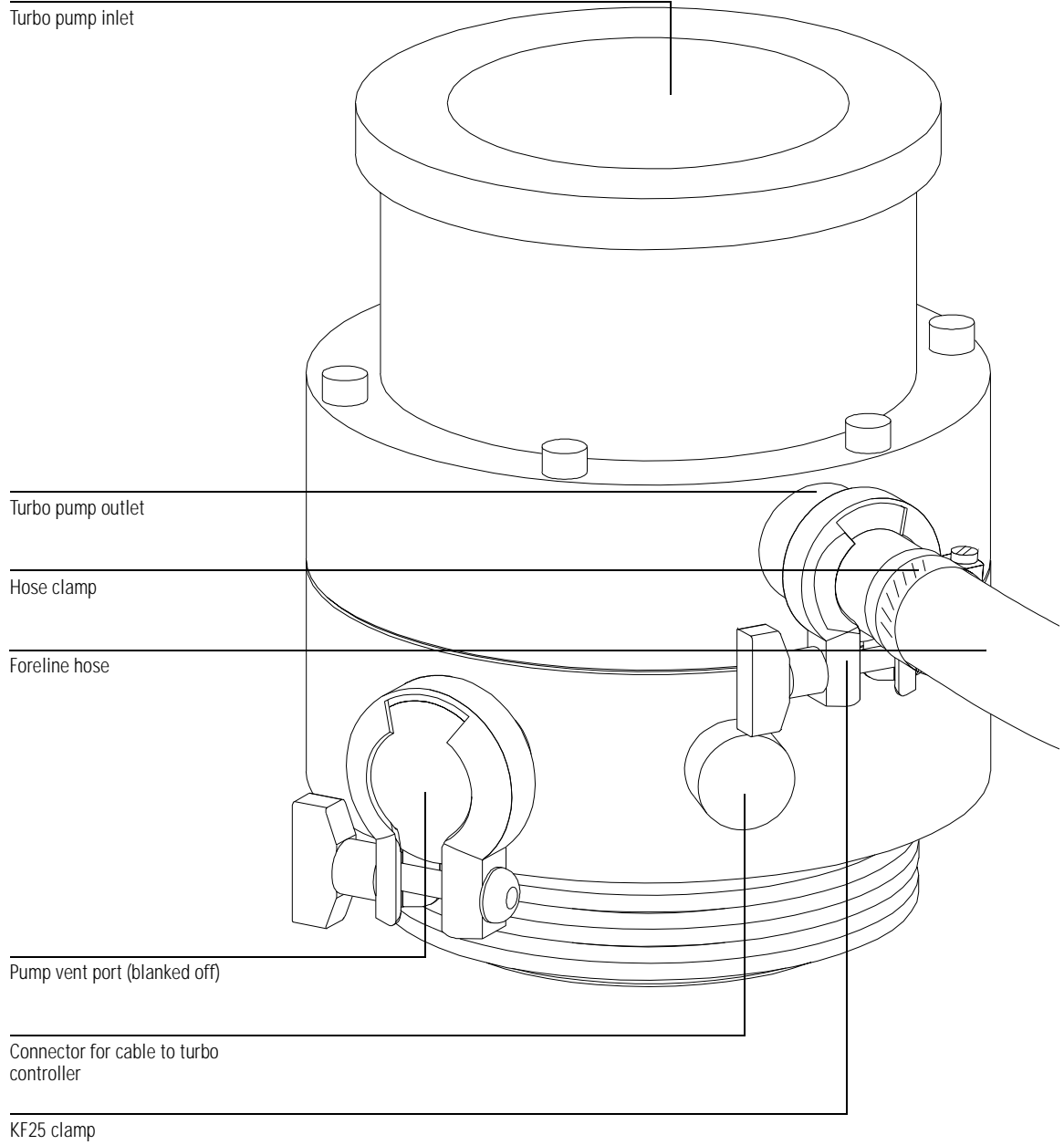

## Calibration valve and vent valve

### Calibration valve

The calibration valve is an electromechanical valve with a vial to hold the tuning compound. The calibration valve is held onto the front end plate by two screws. A small O-ring provides a face seal. The valve is controlled by the MSD ChemStation.

When the calibration valve is opened, tuning compound in the vial diffuses into the vacuum manifold. The valve has a restrictor that controls the entry of the tuning compound into the vacuum manifold. The turbo pump and the diffusion pump MSDs have different calibration valves designed to allow the correct diffusion of calibrant for each vacuum system.

Perfluorotributylamine (PFTBA) is the most commonly used tuning compound. It is required for automatic tuning of the MSD. Other compounds can be used for manual tuning.

### Vent valve

The vent valve knob screws into a threaded port in the front end plate. An O-ring is compressed between the knob and the end plate to form a seal. The threaded end of the knob has an air passage through its threads, allowing air to flow into the manifold when the knob is partially unscrewed. If you turn the knob too far, the O-ring can come loose.

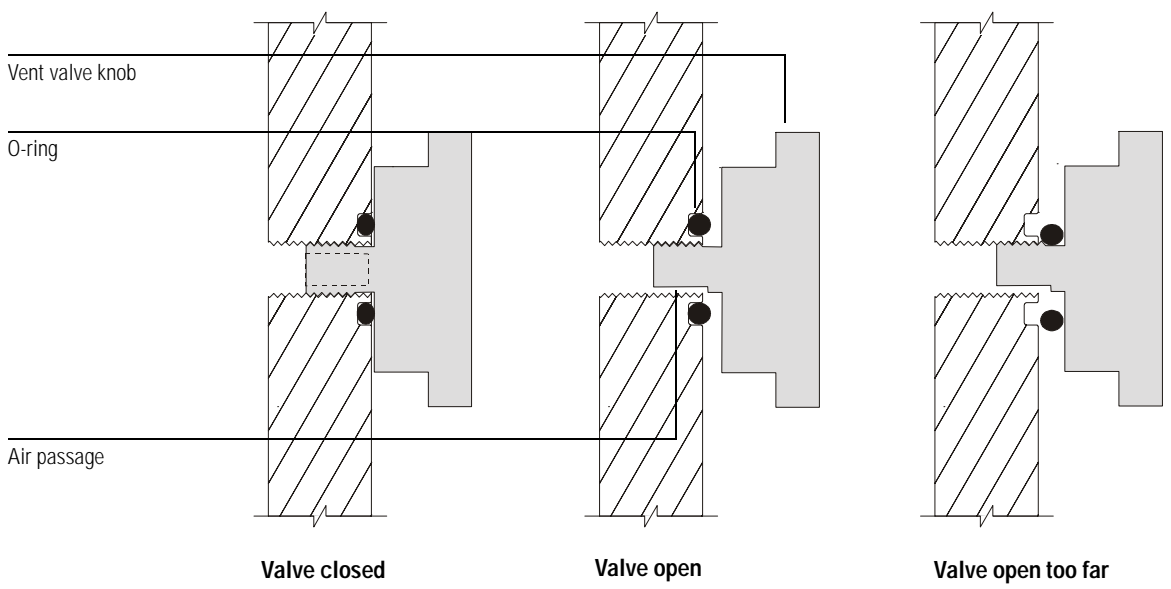
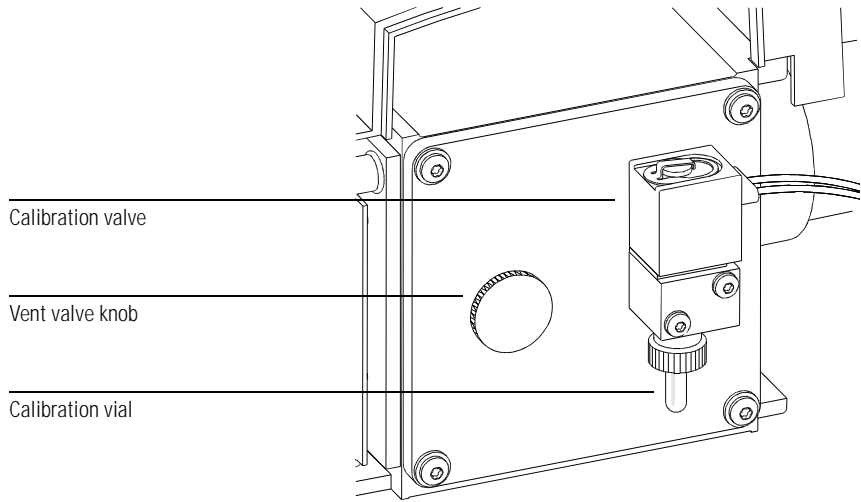

## Triode gauge tube

The MSD is equipped with a triode gauge tube connected to the vacuum manifold. With the optional HP 59864B Gauge Controller, the triode gauge can be used to measure the pressure (high vacuum) in the vacuum manifold. The triode gauge will not operate at pressures above  $8 \times 10^{-3}$  Torr. The triode gauge cannot be used without the gauge controller.

---

**W A R N I N G**

---

**Parts of the triode gauge tube operate at approximately 150 V dc. Turn off the triode gauge before working near it.**

---

**W A R N I N G**

---

**The triode filament can ignite hydrogen. Never turn on the tube if there is a possibility that hydrogen has accumulated in the manifold.**

The triode gauge relies on the ionization of gas molecules to establish a pressure-dependent current flow. In the triode gauge, a regulated electrical current is passed through a filament called the cathode, causing it to emit electrons. The electrons accelerate from the filament toward a surrounding grid which is held at a higher potential (+150 V dc).

The emitted electrons ionize gas molecules in the tube. Positive ions are driven to a grounded wire mesh collector. At the collector, the positive ions regain missing electrons. This generates current in the collector. The number of ions formed is a function of the number of gas molecules present, that is, the gas pressure. Therefore, pressure can be calculated based on the current applied to the filament (cathode) and the current measured in the collector.

Since one end of the triode gauge tube is open to the vacuum manifold, the pressure in the triode gauge is essentially the same as the pressure in the vacuum manifold. To prevent electronic noise from the triode gauge tube from interfering with the detector, a small z-fold baffle is inserted into the stem of the triode gauge tube, and a shield is installed between the tube port and the ion source.

Unlike some other pressure gauges that work by ionization, the triode gauge does not require degassing to remove accumulated ions from the surfaces in the gauge. In some cases, however, new gauge tubes will not display pressures accurately until they have been turned on for several hours.

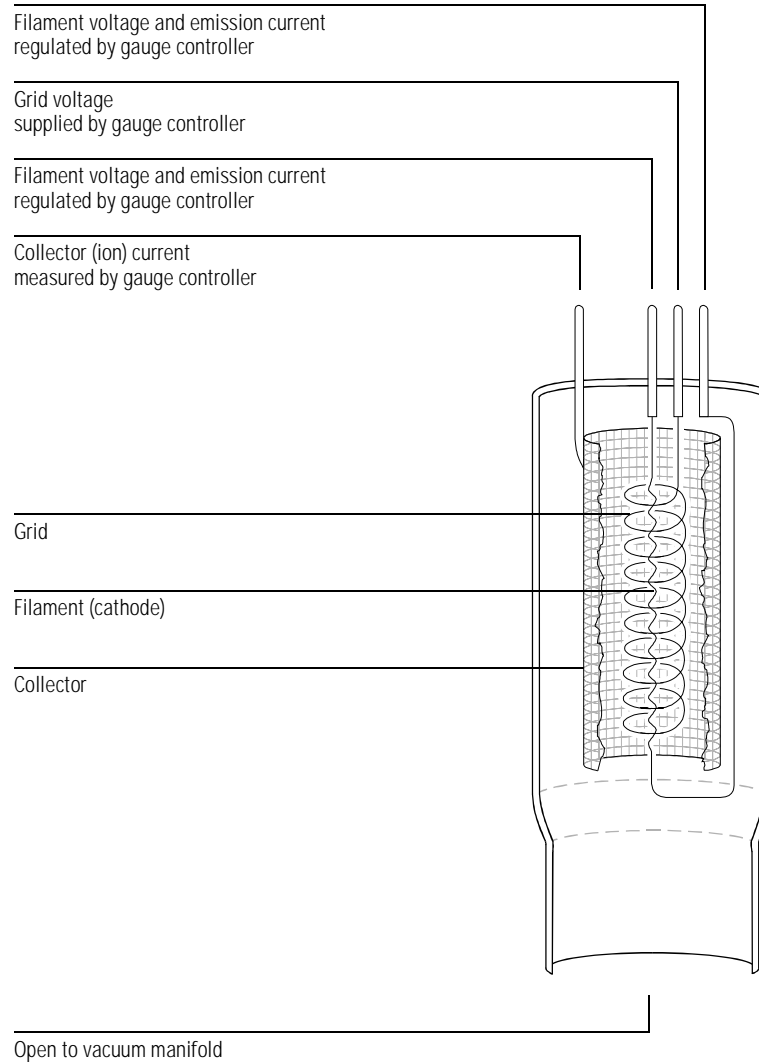

## Gauge controller

The optional HP 59864B Gauge Controller allows you to use the triode gauge tube to monitor the pressure in the MSD vacuum manifold. This can aid in everyday operation and in troubleshooting.

The HP 59864B Gauge Controller includes the controller and a cable for connecting the controller to the triode gauge. A power cord is supplied with a plug appropriate for the country from which the order was placed. The gauge controller can operate on all voltages between 100 and 240 V ac (nominal) and at ac frequencies of 50 to 60 hertz. The fuse in the gauge controller is appropriate for all allowed voltages.

The gauge controller regulates emission current to the filament of the triode gauge tube. It also measures the ion current in the collector. From these data, the gauge controller calculates and displays the pressure present in the vacuum manifold. The vacuum manifold pressure (in Torr) is displayed on the front panel of the controller.

The gauge controller is calibrated for nitrogen ( $N_2$ ). The carrier gas is usually helium, which does not ionize as readily as nitrogen. Therefore, the **indicated** pressure for helium is approximately 6 times lower than the absolute pressure. For example, a reading of  $2.0 \times 10^{-5}$  Torr versus an absolute pressure of  $1.2 \times 10^{-4}$  Torr. The distinction between indicated and absolute pressure is not important for normal operation of the MSD. Of greater concern are changes in pressure from hour to hour or day to day. These changes can indicate air leaks or other problems with the vacuum system. All the pressures listed in this manual are indicated pressures for helium carrier gas. The gauge controller setpoints are also indicated pressures.

### See Also

*To monitor high vacuum pressure, page 44*

---

### W A R N I N G

**The filament in the triode gauge tube can ignite hydrogen. Never turn on the tube if there is a possibility that hydrogen has accumulated in the manifold.**

---

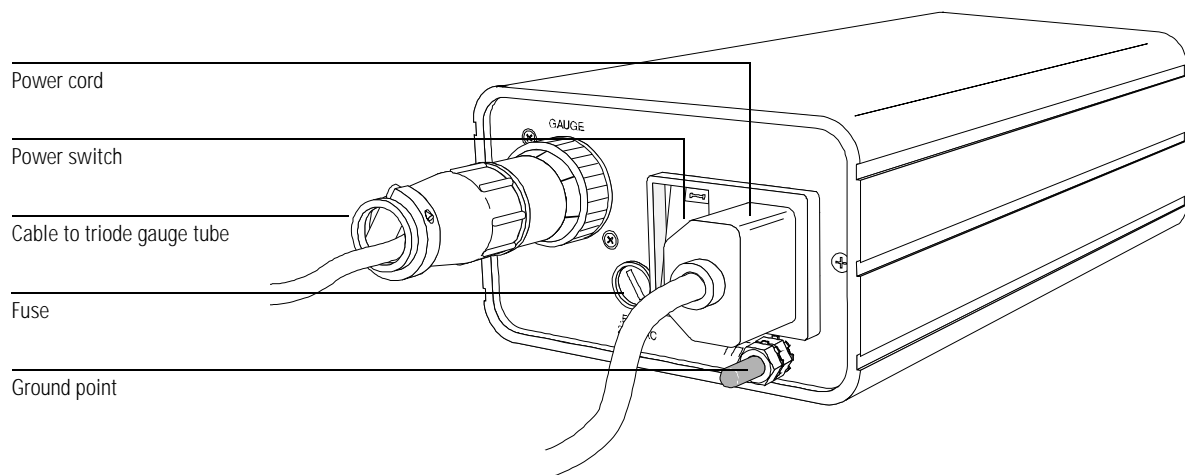
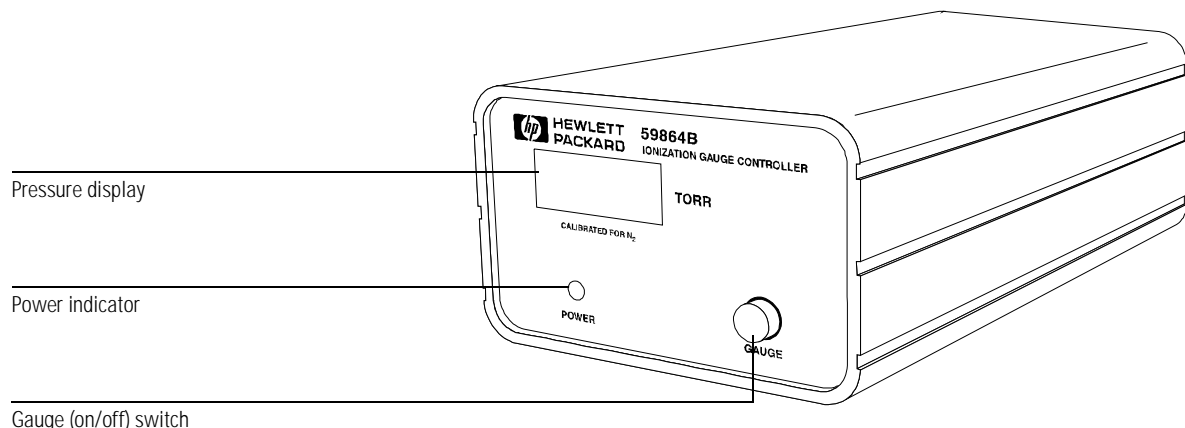



GC/MSD interface, 212

---

## GC/MSD Interface

This chapter describes the function of the GC/MSD interface

---

## GC/MSD interface

The GC/MSD interface is a heated conduit into the MSD for the capillary column. It is bolted onto the right side of the vacuum manifold, with an O-ring seal. A channel machined into the flange for the seal provides thermal isolation between the heated interface and the O-ring and manifold. The GC/MSD interface is covered by a protective cover which should be left in place.

One end of the GC/MSD interface passes through the side of the gas chromatograph and extends into the GC oven. This end is threaded (thread size is 10 × 32), allowing connection of the column with a nut and ferrule. The other end of the GC/MSD interface fits into the ion source. The last two millimeters of the capillary column extend past the end of the guide tube and into the ionization chamber.

The GC/MSD interface is heated by an electric cartridge heater. The heater is powered and controlled by Thermal Aux #2 heated zone of the HP 6890 Series GC. The GC/MSD interface temperature can be set from the MSD ChemStation or from the keypad of the gas chromatograph. A sensor (thermocouple) in the GC/MSD interface monitors the temperature.

The GC/MSD interface should be operated in the 250° to 350°C range. Subject to that restriction, the GC/MSD interface temperature should be slightly higher than the maximum GC oven temperature, but **never** higher than the maximum column temperature.

### See Also

*To install a capillary column using the installation tool, 28*  
*To install a capillary column without the installation tool, 26*

---

### W A R N I N G

---

**The GC/MSD interface operates at high temperatures. If you touch it when it is hot, it will burn you.**

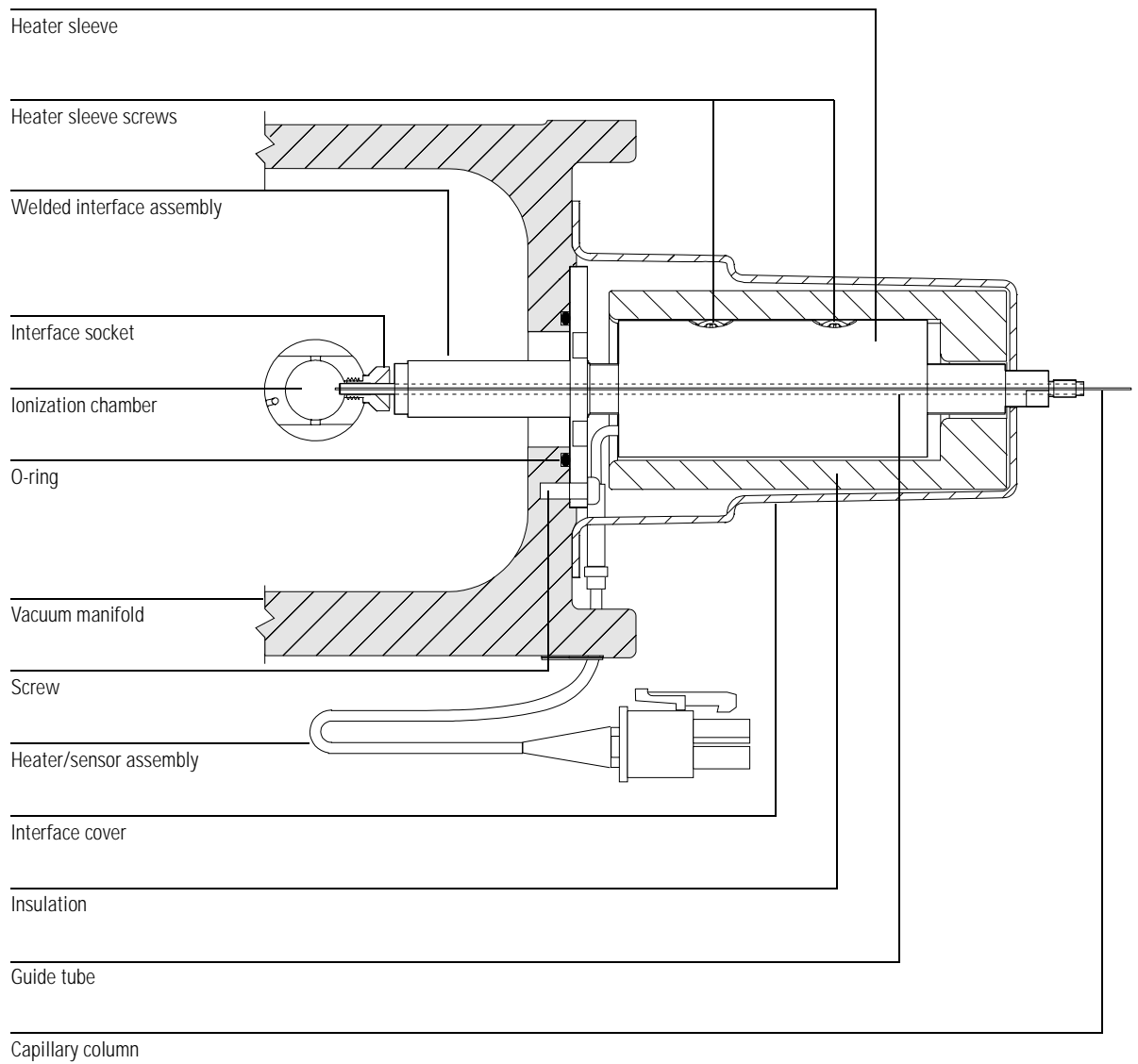



Ion source, 218  
Mass filter, 223  
Detector, 227  
Analyzer heaters and radiators, 230

---

## Analyzer

This chapter describes the parts of the analyzer

---

# Analyzer

## ***The analyzer is the heart of the MSD***

The analyzer ionizes the sample, filters the ions, and detects them. The sample components exiting the GC column flow into the ion source. In the ion source, the sample molecules are ionized and fragmented. The resulting positive ions are repelled from the ion source into the quadrupole mass filter. The mass filter allows selected ions to pass through the filter and strike the detector. The detector generates a signal current proportional to the number of ions striking it.

The analyzer is attached to the vacuum side of the side plate. The side plate is hinged to allow easy access to the analyzer. Both the ion source and the mass filter are independently heated. Each is mounted inside a radiator for correct heat distribution.

Each of the parts of the analyzer is discussed in the following material.

## ***The analyzer has four basic components***

The analyzer consists of the following components:

- Ion source
- Mass filter
- Detector
- Heaters and radiators

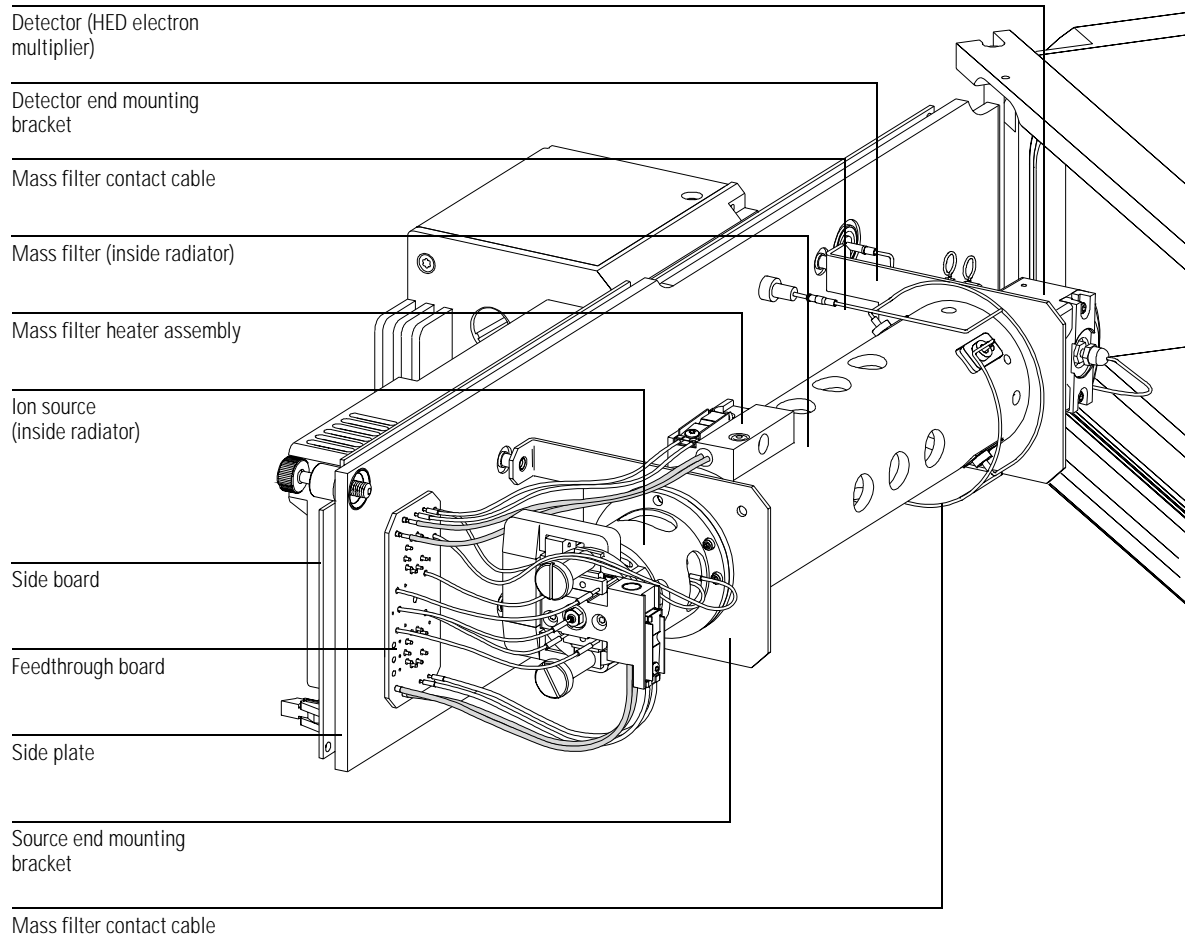

## **Ion source**

The ion source operates by electron ionization (EI). The sample enters the ion source from the GC/MSD interface. Electrons emitted by a filament enter the ionization chamber, guided by a magnetic field. The high-energy electrons interact with the sample molecules, ionizing and fragmenting them. The positive voltage on the repeller pushes the positive ions into the lens stack, where they pass through several electrostatic lenses. These lenses concentrate the ions into a tight beam, which is directed into the mass filter.

### **Ion source body**

The ion source body is a cylinder. Its cylindrical geometry ensures proper alignment of the lens stack. It holds the other parts of the ion source. With the repeller and the drawout plate, it forms the ionization chamber. The ionization chamber is the space where the ions are formed. Slots in the source body help the vacuum system to pump away carrier gas and un-ionized sample molecules or fragments.

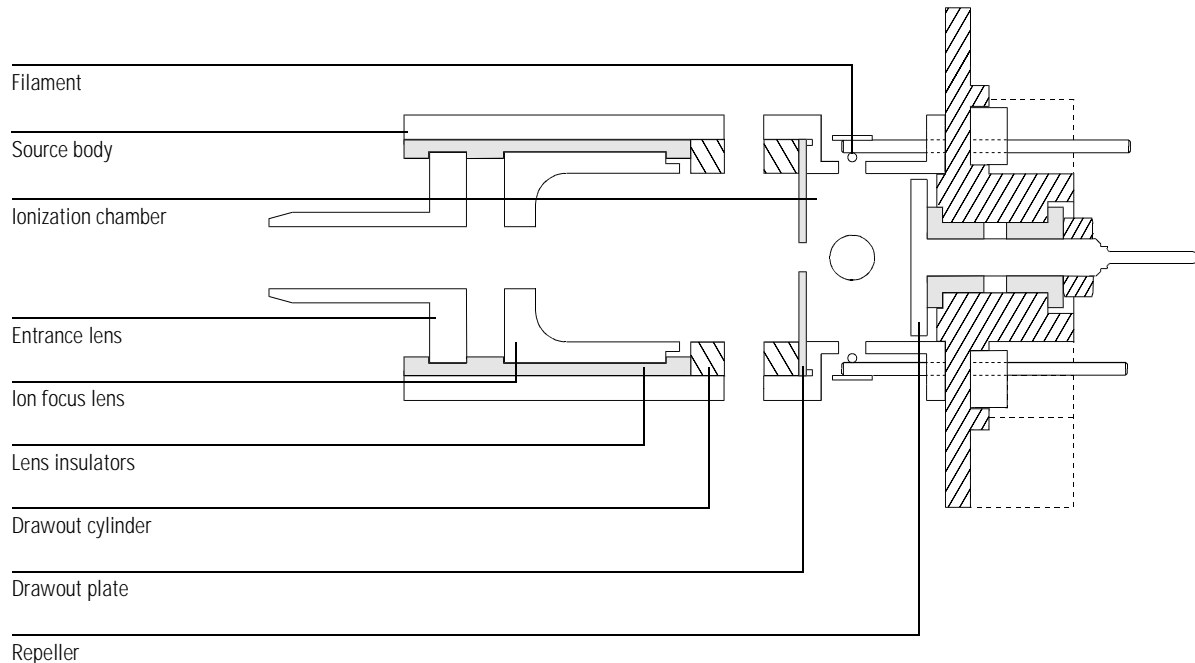

## Filaments

Two filaments are located on opposite sides of the outside of the ion source. The **active** filament carries an adjustable ac emission current. The emission current heats the filament, causing it to emit electrons; these electrons ionize the sample molecules. In addition, **both** filaments have an adjustable dc bias voltage. The bias voltage determines the energy on the electrons, usually -70 eV.

The filament is shut off automatically if there is a general instrument shutdown. There are three parameters that affect the filaments: filament selection (**Filament**), filament emission (**Emission**) current, and electron energy (**EleEnergy**).

### Filament selection

The filament selection parameter (**Filament**) allows you to select which filament in the ion source is active.

Sometimes, one filament will give better performance than the other. To select the

**Ion source**

better of the two filaments, run two autotunes, one with each filament. Use the filament that gives the best results.

***Emission current***

The filament emission current (**Emission**) is variable between 0 and -315  $\mu\text{A}$ , but should be set to the software default for normal operation.

***Electron energy***

The electron energy (**EleEnergy**) is the amount of energy on the ionizing electrons. The electron energy is determined by the bias voltage; -70 V dc bias on the filament causes emitted electrons to possess -70 eV (electron volts). This value is adjustable between -5 to -241 V dc, but for normal operation, set this parameter to 70.

### ***Filament care***

Like the filaments in incandescent light bulbs, the ion source filaments will eventually burn out. Certain practices will reduce the chance of early failure:

- If you have an optional HP 59864B Gauge Controller, use it to verify that the system has an adequate vacuum before turning on the analyzer, especially after any maintenance has been performed.
- If you are controlling your MSD from the Edit Parameters screen, always select **MSOff** before changing any of the filament parameters.
- When setting up data acquisition parameters, set the solvent delay so that the analyzer will not turn on while the solvent peak is eluting.
- When the software prompts **Override solvent delay?** at the beginning of a run, ***always*** select **NO**.
- Higher emission current will reduce filament life.
- Lower electron energy will reduce filament life.

### **Magnet**

The field created by the magnet directs the electrons emitted by the filament into and across the ionization chamber. The magnet assembly is a permanent magnet with a charge of 350 gauss in the center of the field.

### **Repeller**

The repeller forms one wall of the ionization chamber. A positive charge on the repeller pushes positively-charged ions out of the source through a series of lenses. The repeller voltage is also known as the ion energy, although the ions only receive about 20% of the repeller energy. The repeller voltage can be varied from 0 to +42.8 V dc. Some tune programs use a fixed repeller voltage. Others ramp the repeller voltage to find the optimum setting.

- Setting repeller voltage too low results in poor sensitivity and poor high mass response.
- Setting repeller voltage too high results in precursors (poor mass filtering) and poor low mass resolution.

**Ion source****Drawout plate and cylinder**

The drawout plate forms another wall of the ionization chamber. The ion beam passes through the hole in the drawout plate and into the drawout cylinder. The drawout cylinder is slotted. The slots correspond to slots in the source body. These slots allow carrier gas and un-ionized sample molecules or fragments to be pulled away by the vacuum system. The drawout plate and drawout cylinder are both at ground potential.

**Ion focus**

The voltage on the ion focus lens can be varied from 0 to -127 V dc. A typical voltage is between -70 and -90 V dc. In general:

- Increasing the ion focus voltage improves sensitivity at lower masses.
- Decreasing the ion focus voltage improves sensitivity at higher masses.
- Incorrect ion focus adjustment results in poor high mass response.

**Entrance lens**

The entrance lens is located at the entrance to the quadrupole mass filter. This lens minimizes the fringing fields of the quadrupole which discriminate against high-mass ions. There is a permanent +4.4 volt voltage added to the entrance lens. The total voltage applied to the entrance lens is the sum of the entrance lens offset and entrance lens gain and the +4.4 volt permanent offset.

$$\text{Entrance lens voltage} = +4.4 \text{ V dc} + \text{offset} + (\text{gain} \times \text{mass})$$

***Entrance lens offset***

The entrance lens offset (**EntOff**) controls the fixed voltage applied to the entrance lens. It can be varied from 0 to -64 V dc (-20 V is typical). Increasing the entrance lens offset generally increases the abundance of ions at low masses without substantially decreasing the abundance of high mass ions.

***Entrance lens gain***

Entrance lens gain (**EntLens**) controls the variable voltage applied to the entrance lens. It determines how many volts are applied for each amu. It can be varied from 0 to -128 mV/amu. A typical range is 0 to -40 mV/amu.

## Mass filter

The mass filter separates ions according to their mass-to-charge ratio ( $m/z$ ). At a given time, only ions of a selected mass-to-charge ratio can pass through the filter to the detector. The mass filter in the MSD is a quadrupole.

The quadrupole is a fused-silica (quartz) tube coated with a thin layer of gold. The four hyperbolic surfaces create the complex electric fields necessary for mass selection. Opposing segments are connected; adjacent segments are electrically isolated. One pair has positive voltages applied, the other negative.

A combined direct current (dc) and radio frequency (RF) signal is applied to the two pairs of segments. The magnitude of the RF voltage determines the mass-to-charge ratio of the ions that pass through the mass filter and reach the detector. The ratio of dc-to-RF voltage determines the resolution (widths of the mass peaks). There are several parameters that control the dc and RF voltages. All these parameters are set by Autotune, but also can be manually adjusted in the Edit Parameters window:

- AMU gain (**AmuGain**)
- AMU offset (**AmuOffs**)
- 219 width (**Wid219**)
- DC polarity (**DC Pol**)
- Mass (axis) gain (**MassGain**)
- Mass (axis) offset (**MassOffs**)

### AMU gain

AMU gain (**AmuGain**) affects the ratio of dc voltage to RF frequency on the mass filter. This controls the widths of the mass peaks.

- Higher gain yields narrower peaks.
- AMU gain affects peaks at high masses more than peaks at low masses.

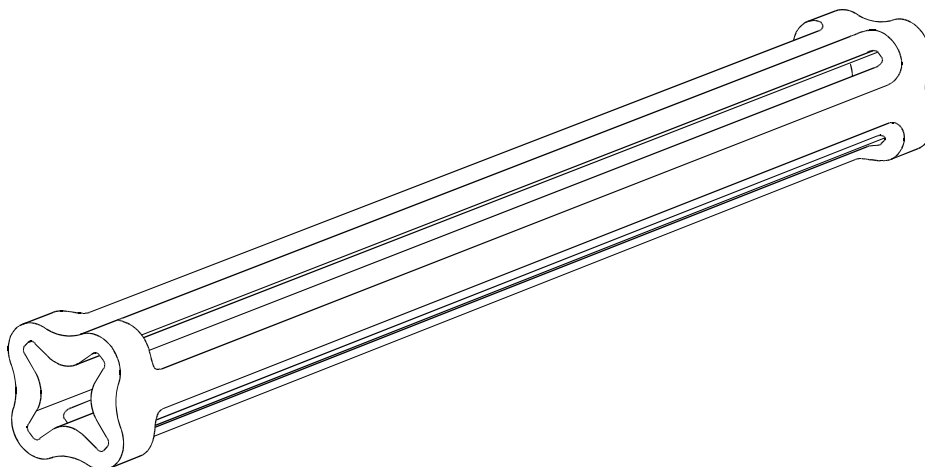
**Mass filter****AMU offset**

AMU offset (**AmuOffs**) also affects the ratio of dc voltage to RF frequency on the mass filter.

- Higher offset yields narrower peaks.
- AMU offset generally affects peak widths equally at all masses.

**219 width**

$m/z$  219 is a prominent ion near the middle of the mass range of PFTBA. The width parameter (**Wid219**) makes small corrections to the  $m/z$  219 peak width. Amu gain and amu offset must be readjusted after the 219 width is changed. If you are tuning with a compound other than PFTBA, there may not be an ion at  $m/z$  219. In that case, set the 219 width to the last value found for it by Autotune or set it to 0.

### DC polarity

The dc polarity (**DC Pol**) parameter selects the orientation of the direct current applied to the quadrupole mass filter. The dc polarity that works best for your MSD is determined at the factory. It is listed on the final test sheet accompanying your MSD. It is also listed on a label on the cover over the RF coils. This cover can be viewed by removing the upper MSD cover.

---

**CAUTION**

---

Using the non-preferred dc polarity may result in very poor performance. Always use the factory-specified polarity.

### Mass (axis) gain

Mass gain (**MassGain**) controls the mass assignment, that is, assignment of a particular peak to the correct  $m/z$  value.

- A higher gain yields higher mass assignment.
- Mass gain affects peaks at high masses more than peaks at low masses.

### Mass (axis) offset

Mass offset (**MassOffs**) also controls the mass assignment.

- A higher offset yields higher mass assignment.
- Mass offset generally affects peaks equally at all masses.

**Mass filter****Quadrupole maintenance**

The mass filter requires no periodic maintenance. It should not be removed from the radiator. If **absolutely** necessary (that is, if the only alternative is replacement), the quadrupole can be cleaned. Cleaning must be performed by Hewlett-Packard service personnel.

---

**CAUTION**

---

**Never** put the quadrupole in an ultrasonic cleaner.

---

**CAUTION**

---

**Never** change the physical orientation of the quadrupole mass filter.

---

**CAUTION**

---

The fused-quartz quadrupole is fragile and will break if dropped or handled roughly.

---

**CAUTION**

---

The material in the cusps of the quadrupole is very hygroscopic. If exposed to water, the quadrupole must be dried **very** slowly to prevent damage.

---

## Detector

The detector in the MSD analyzer is a high energy conversion dynode (HED) coupled to an electron multiplier (EM). The detector is located at the exit end of the quadrupole mass filter. It receives the ions that have passed through the mass filter. The detector generates an electronic signal proportional to the number of ions striking it. The detector has three main components: the detector focus lens, the high energy dynode, and the electron multiplier horn.

### Detector focus lens

The detector focus lens directs the ion beam into the HED, which is located off axis. The voltage on the detector focus lens is fixed at -354 V.

### High energy dynode

The high energy dynode (HED) operates at -10,000 volts, attracting the positive sample ions exiting the quadrupole. The HED is located off-axis from the center of the quadrupole mass filter to minimize signals due to photons, hot neutrals, and electrons coming from the ion source. When the ion beam hits the HED, electrons are emitted. These electrons are attracted to the more positive electron multiplier horn.

### Electron multiplier horn

The electron multiplier horn carries a voltage of up to -3000 volts at its opening and 0 volts at the other end. The electrons emitted by the HED strike the EM horn and cascade through the horn, liberating more electrons as they go. At the far end of the horn, the current generated by the electrons is carried through a shielded cable outside the analyzer to the signal amplifier board.

The voltage applied to the electron multiplier horn determines the gain. The voltage is adjustable from 0 to -3000 V dc. Use the electron multiplier voltage found in autotune as a baseline for the electron multiplier voltage setting.

- To increase signal strength, increase the electron multiplier voltage.
- For concentrated samples where less signal strength is needed, decrease the electron multiplier voltage.

### Detector

As the EM horn ages, the voltage (**EMVolts**) required by the electron multiplier increases over time. If the electron multiplier voltage must always be set at or near -3000 V dc to complete Autotune, with no other probable cause, it may need to be replaced. Check your tune charts for gradual degradation, which indicates wearing out. Select **View Tunes** from the Qualify menu in the Instrument Control view to see the tune charts. Sudden changes usually indicate a different type of problem.

#### See Also

*Troubleshooting (HP5973 MSD)* in the online help for more information about symptoms that may indicate electron multiplier problems.

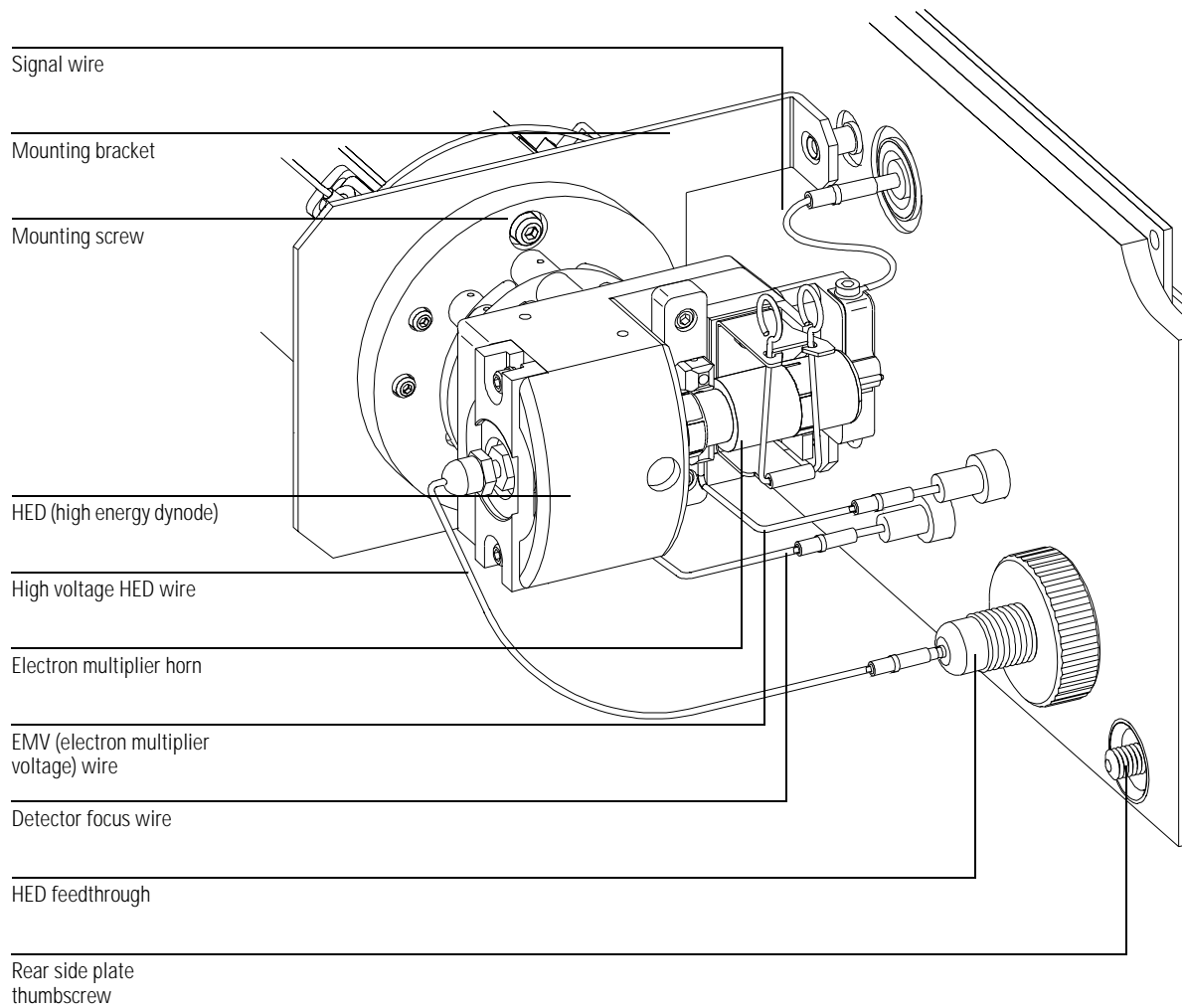

---

## Analyzer heaters and radiators

The ion source and mass filter are housed in cylindrical aluminum tubes called radiators. The radiators control the distribution of heat in the analyzer. They also provide electrical shielding for analyzer components. The source heater and temperature sensor are mounted in the source heater block. The mass filter (quad) heater and temperature sensor are mounted on the mass filter radiator. Analyzer temperatures can be set and monitored from the MSD ChemStation.

In selecting the temperatures to use, consider the following:

- Higher temperatures help keep the analyzer clean longer.
- Higher ion source temperatures result in more fragmentation and therefore lower high-mass sensitivity.

After pumpdown, it takes at least 2 hours for the analyzer to reach thermal equilibrium. Data acquired sooner may not be reproducible.

Recommended settings (for EI operation):

- Ion source 230°C
- Quadrupole 150°C

---

### **CAUTION**

---

Do not exceed 200°C on the quadrupole or 250°C on the ion source.

The GC/MSD interface, ion source, and mass filter (quad) heated zones interact. The analyzer heaters may not be able to accurately control temperatures if the set-point for one zone is much lower than that of an adjacent zone.

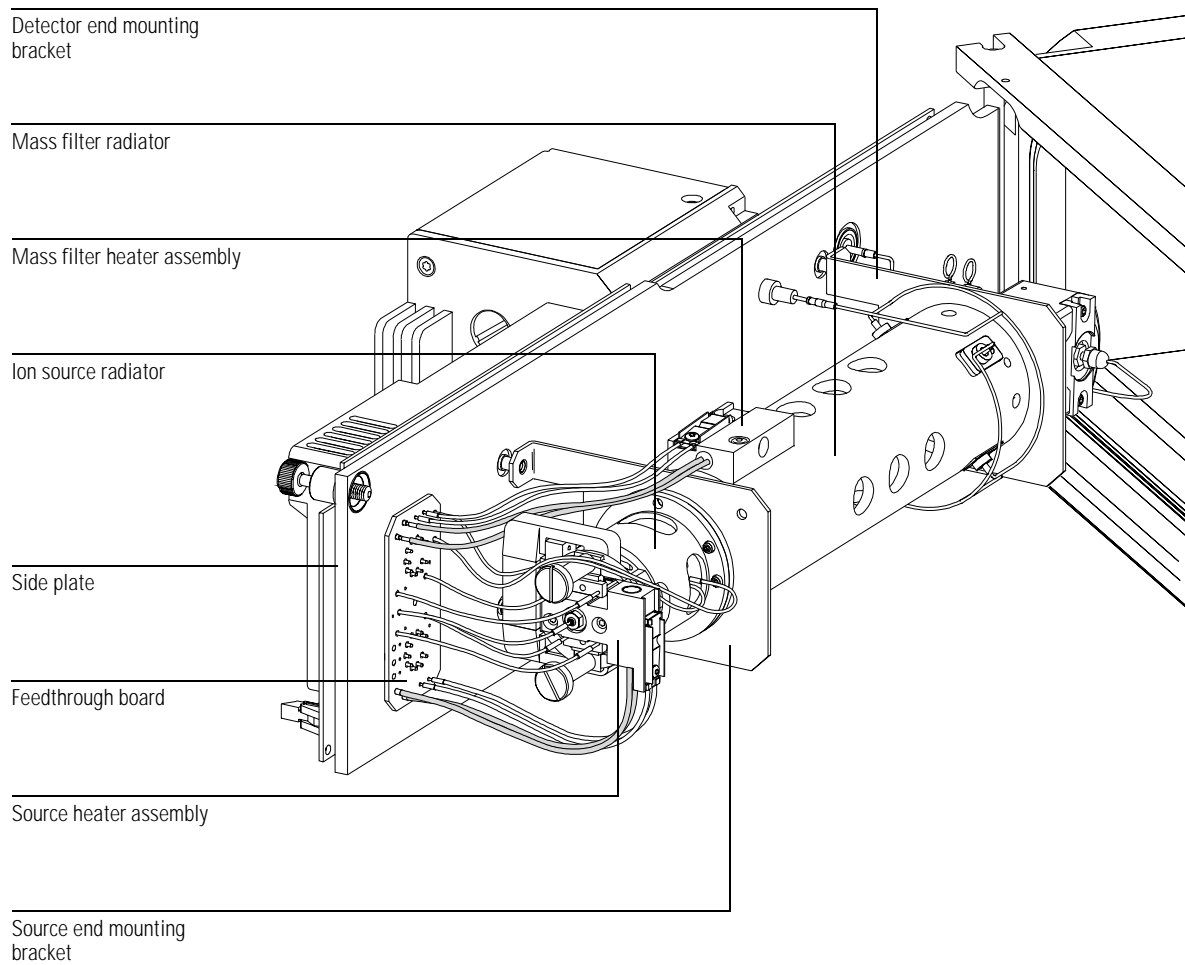



Side board, 236  
Electronics module, 237  
Main board, 238  
Signal amplifier board, 239  
HP-IB/MS control card, 240  
AC board, 241  
Power supplies, 243  
Toroid transformer, 244  
Back panel and connectors, 245  
Interfacing to external devices, 248  
Status display and power switch, 250  
Turbo pump controller, 252

---

## Electronics

This chapter describes the MSD electronics

---

# Electronics

The following assemblies make up the MSD electronics:

- Electronics module
- Main board
- Signal amplifier board
- HP-IB/MS control card
- AC board
- Low voltage (ac-dc) power supply
- High voltage (HED) power supply
- Toroid transformer assembly
- Back panel connectors
- Status display and power switch
- Side board
- Turbo pump controller

Each is discussed in this chapter. Except for the *Back panel and connectors*, *Status display and power switch*, and *Interfacing to other devices* sections, most of this material is not essential for day-to-day operation of the MSD. It may be of interest to persons responsible for servicing the MSD.

---

## W A R N I N G

---

**Dangerous voltages are present under the safety covers. Do not remove safety covers. Refer servicing to your Hewlett-Packard service representative.**

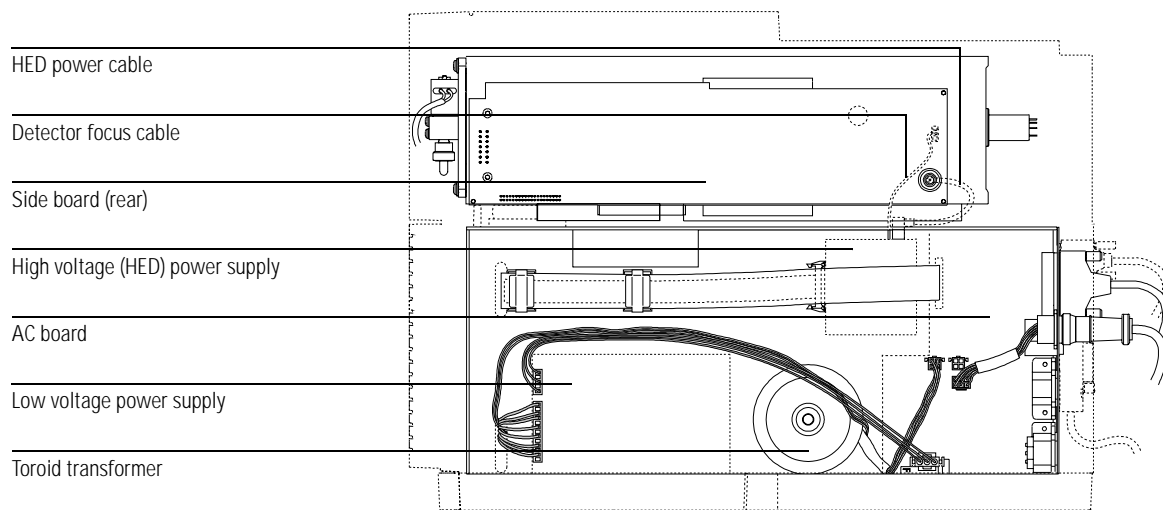
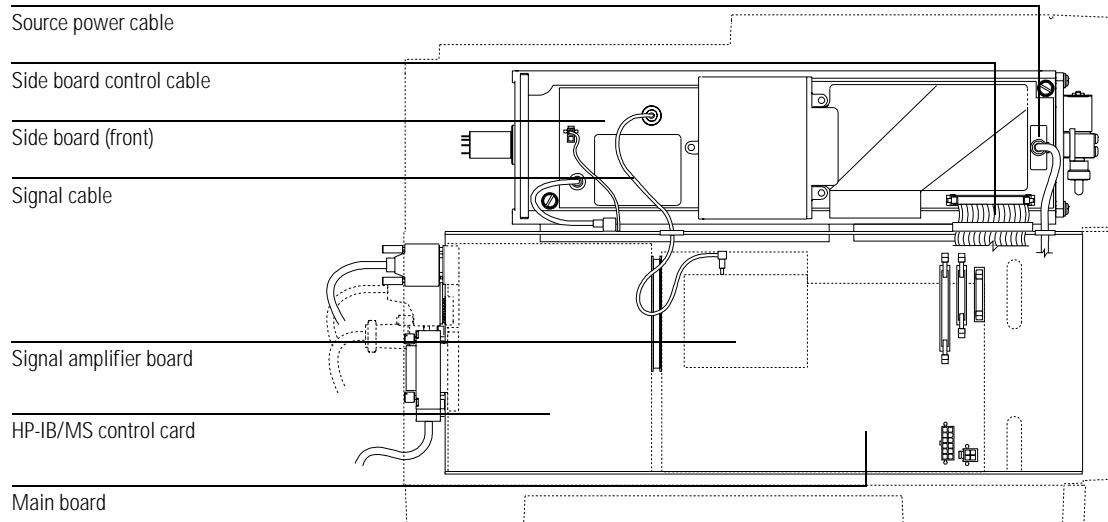

## Side board

The side board is mounted on the side plate. It performs the following functions:

- Provides the 1 MHz reference clock for the RF amplifier.
- Generates the RF component of the voltage applied to the quadrupole mass filter according to a signal from the main board. The amplitude of this voltage is proportional to the mass selected.
- Generates the dc component of the voltage applied to the quadrupole mass filter. The magnitude of this voltage is proportional to the RF voltage.
- Passes voltages generated on the main board, and the detector focus voltage from the HED power supply, to elements in the ion source and the detector.
- Generates and adjusts filament emission current and electron energy as controlled by the main board.
- Switches the filament power from one filament to the other.
- Monitors for RF faults and shuts down the analyzer one is detected.

## Electronics module

Most of the electronics in the MSD are contained in the electronics module. The whole electronics module can be replaced, if necessary, by your Hewlett-Packard service representative.

The electronics module contains:

- Main board
- Signal amplifier board
- HP-IB/MS control card
- AC board (power distribution / vacuum control board)
- Low voltage (ac-dc) power supply
- High voltage (HED) power supply
- Toroid transformer assembly

## Main board

The main board is mounted on the outer side of the electronics module. The main board performs the following functions:

- Receives and decodes digital instructions from the HP-IB/MS control card.
- Sends digital information to the HP-IB/MS control card.
- Generates voltages for the ion source lenses.
- Generates control signals for alternate filament selection, filament emission current, and electron energy. Generates control signals for quadrupole RF drive, dc/RF ratio adjustment, dc polarity selection, and all detector voltages.
- Performs analog-to-digital conversion for the coil DIP signal, ion source and mass filter temperature signals, and foreline pressure or turbo pump speed signal.
- Monitors the signals from the vacuum system and fans; and monitors the filament status, HV fault and RF fault signals from the side board. Activates the shutdown line when the analyzer electronics must be disabled.
- Generates the control signals (on and off) used by the ac board for the high vacuum pump and calibration valve.
- Generates  $\pm 280$  V dc (nominal) power for main board lens amplifiers and side board dc amplifiers.
- Supplies and controls the power for the ion source and quadrupole (mass filter) heaters.
- Contains LEDs for the front panel status display.
- Provides 24 V dc power for the cooling fans.

## Signal amplifier board

The signal amplifier board amplifies the output of the detector. The signal amplifier circuit produces an output voltage of 0 to 10 volts dc, proportional to the logarithm of the input current of 3 picoamps to 50 microamps.

An analog-to-digital converter converts the amplifier output voltage to digital information. The HP-IB/MS control card “unlogs” the data into abundance counts proportional to the detector signal current.

## HP-IB/MS control card

The HP-IB/MS control card is located to the left of the main board on the electronics panel. The HP-IB/MS control card has two main functions:

- Providing a communication interface between the MSD and the data system.
- Providing real-time control of the MSD, freeing the data system for other tasks.

Functional areas of the HP-IB/MS control card include:

- Instrument controller
- Data processor
- Main processor
- Serial communication processor
- HP-IB controller
- Remote start processor
- Random access memory (RAM)

---

## AC board

The ac board is mounted on the opposite side of the electronics panel from the HP-IB/MS control card. The ac board is also sometimes called the power distribution / vacuum control board. The ac board performs the following functions:

- Has two sockets for connecting the toroid transformer. The socket used depends on the line voltage.
- Distributes ac line power to the ac/dc power supply, the foreline pump, the toroid transformer.
- Turns on the diffusion pump once the foreline pressure is low enough.
- Regulates the ac power to the diffusion pump heater.
- Turns off the diffusion pump if the foreline pressure is too high or if the diffusion pump is too hot.
- Controls the foreline gauge.
- Passes the foreline pressure signal from the foreline gauge or turbo pump speed and other vacuum status information to the main board.
- Turns off the foreline pump in case of a problem with pumpdown.
- Provides power and logic interface to turbo controller.
- Turns the calibration valve on or off as directed to by the main board.
- Turns the diffusion pump on or off as directed to by the main board.
- Provides the voltage for the calibration valve.

The power regulator ensures that the diffusion pump heater receives constant power, even if there are fluctuations in the ac line voltage. It measures the voltage across the heater and the current through it, multiplies them together, and compares the result with a standard value. Any discrepancy is applied as an error signal to adjust the power.

If the power distribution board senses a malfunction in the diffusion pump power regulator, it shuts off power to the diffusion pump.

In turbo pump MSDs, the ac board sends control signals to, and receives turbo pump status information from, the turbo pump controller.

## AC board

### Pumpdown safety shutdown

In MSDs with serial numbers XX820XXXXX and above, the ac board will shut down both the high vacuum and the foreline pump if the system fails to pump down correctly. The conditions that trigger shutdown are:

- Diffusion pump MSD: foreline pressure above 300 mTorr after 4 minutes
- Turbo pump MSD: turbo pump speed below 80% after 8 minutes

This is usually because of a **large** air leak: either the sideplate has not sealed correctly or the vent valve is still open. This feature helps prevent the foreline pump from sucking air through the system, which can damage the analyzer and pump.

To restart the MSD, find and correct the air leak, then switch the power off and on. Be sure to press on the sideplate when turning on the MSD power to ensure a good seal.

## Power supplies

### **Low voltage (ac-dc) power supply**

The low voltage power supply is mounted next to the toroid transformer in the electronics module. A universal input power supply, it converts ac line voltage into the dc voltages used by the rest of the electronics. The power supply generates the following dc voltages:

- +24 V (nominal)
- +15 V (nominal)
- -15 V (nominal)
- +5 V (nominal)

### **High voltage (HED) power supply**

The high voltage power supply provides the -10,000 volts dc for the high energy dynode (HED) in the detector. The HED power supply also provides the 350 volts dc for the detector focus lens. Due to the high impedance of this circuit, it is not practical to measure the detector focus voltage with a handheld voltmeter.

## Toroid transformer

The toroid transformer is mounted next to the ac board. It provides 24 V ac for the mass filter and source heater circuits. The input wires take 120 V ac or 200 – 260 V ac from the ac board. Depending on the line voltage, one of two connectors on the ac board is used; determined by the position of a jumper on the AC board. The output wires connect to the main board.

## Back panel and connectors

The back panel contains several connectors, primary fuses, and the HP-IB address switches. Most of these components are part of the ac board or the HP-IB/MS control card, and extend through the back panel. These include:

- Remote start connector
- I/O (**HP-IB**) connector
- High vacuum signal (**HIVAC SIGNAL**) connector
- High vacuum power (**HIVAC POWER**) connector
- Primary fuses
- Power cord receptacle
- Foreline pump cord receptacle
- HP-IB address switches

The following material describes the functions of these connectors and controls.

### **Remote start connector**

The remote start connector is the external connector for the remote start circuitry on the HP-IB/MS control card. It receives remote start signals from the GC.

### **I/O (HP-IB) connector**

The HP-IB cable from the data system is connected to the I/O (**HP-IB**) connector. This cable carries all data communication between the MSD ChemStation and the MSD.

### **HP-IB address switch**

The HP-IB address switch is located on the HP-IB/MS control card. A port in the back panel allows access to the switch. Switch positions should not be changed for normal operation.

## Back panel and connectors

### **High vacuum signal (HIVAC SIGNAL) connector**

The high vacuum signal connector is on the ac board, extending to the back panel. The high vacuum signal cable carries control signals to the turbo controller from the ac board, and high vacuum pump status information to the ac board. This cable also carries control and power to the calibration valve and the high-vacuum cooling fan.

### **High vacuum power (HIVAC POWER) connector**

The high vacuum power connector carries power for the diffusion pump heater or the turbo controller. The high vacuum power jumper connects the ac board to the high vacuum power connector.

### **Power cord receptacle**

The ac power cord brings in all electrical power for the MSD. The power cord can be detached from the MSD. The ac power receptacle is on the ac board, extending through the back panel.

### **Foreline pump power cord receptacle**

The foreline pump power cord receptacle provides ac power for the foreline pump. If the power switch is off, no power is supplied to the foreline pump. The ac power receptacle is on the ac board, extending through the back panel.

### **Primary fuses**

The primary fuses limit current into the MSD in case of a short circuit in the foreline pump. The primary fuses are on the ac board, extending through the back panel.

HP-IB address switch

Remote start cable

High vacuum control cable

High vacuum power cable

Primary fuses

Power cord receptacle

Foreline pump power cord

HP-IB cable

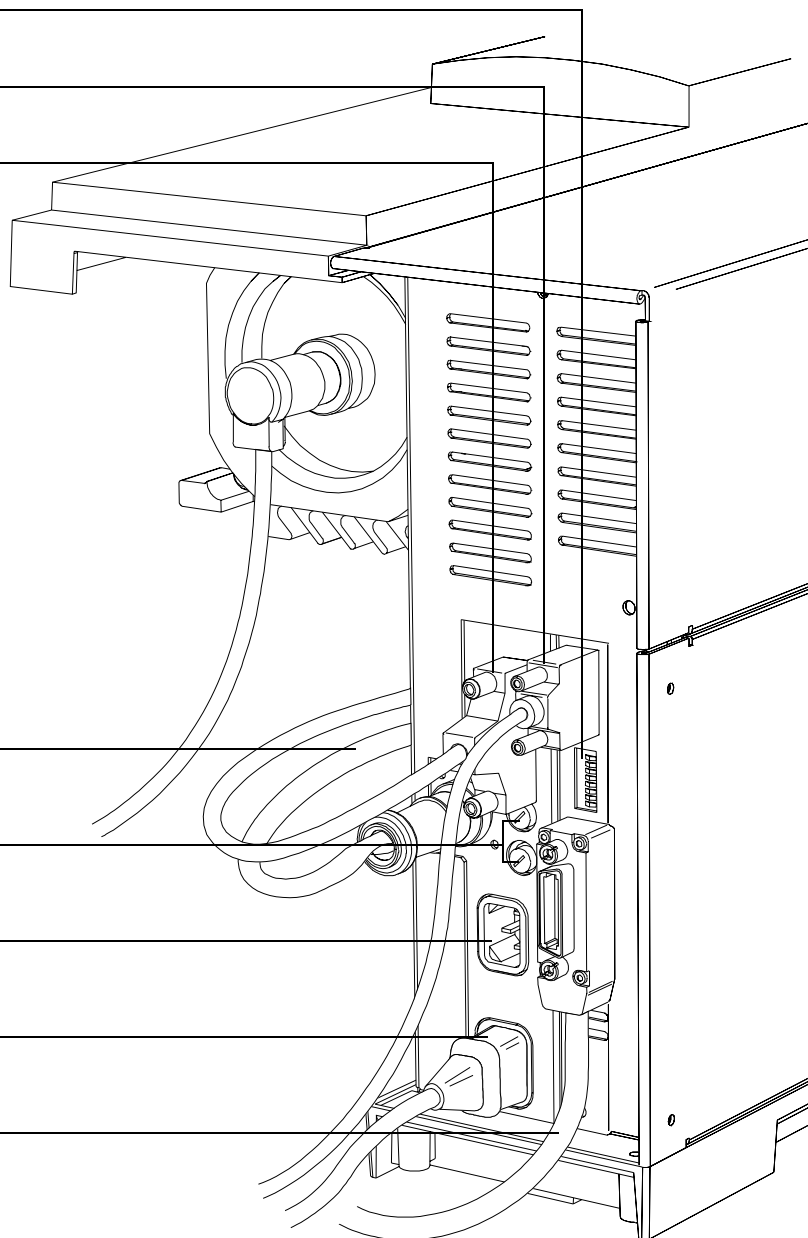

---

## Interfacing to external devices

### Remote control processor

The remote control processor on the HP-IB/MS control card synchronizes start-run signals with GCs and other devices. The functions of the remote control processor are extended to the remote start (**Remote**) connector on the back panel of the MSD. The remote start cable connects the GC and the MSD.

### Remote start signals

It is often necessary to communicate with external devices (for example, a purge-and-trap) during a run. Typically, these communications are:

- Requests to send a system ready signal
- Receive a start run signal from an external device
- Program the timing of events during a run

MSD remote start connector

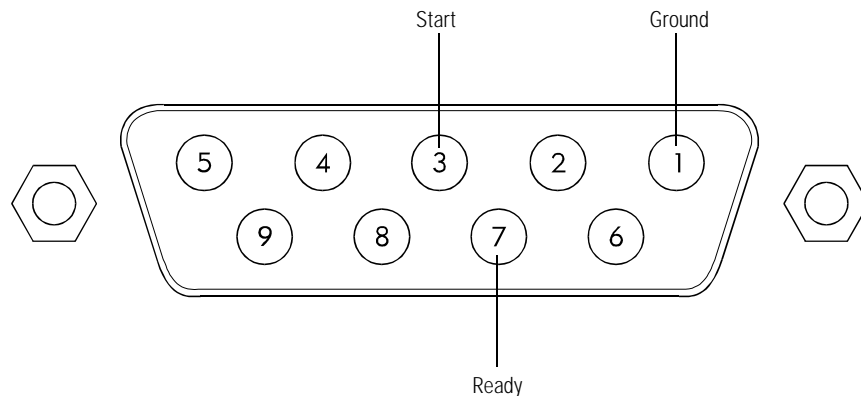

***System ready***

When interfacing to an external device, it is often desirable to send a system ready signal to the device. In the case of a multi-sample Tekmar purge-and-trap, each sample is purged onto a trap where it waits for a ready signal. On receipt of the ready signal, the desorption cycle begins. When a specific temperature has been reached, the purge-and-trap closes a contact to indicate the run has started.

The ready pin on the remote start connector on the GC is held low at all times except when the GC, MSD, and data system are all ready. On system ready, a logic high of 5 V dc is present between that pin and any ground. This same high can be detected between the ready and ground pins on the remote start connector on the MSD.

***Start run input***

The best way to generate a start run signal is to use the remote start connector on the GC. Since remote start cables are made for most common devices, this is often the simplest way. A general-purpose remote start cable (05890-61080), which is also available, terminates in spade lugs. Care must be taken to ensure that the system is actually ready before the start run signal is sent.

If necessary, the remote start connector on the back of the MSD can be used to send the start run signal. A contact closure between the start and ground pins will start the run if the system is ready.

## Status display and power switch

The MSD has a status display on the lower left of the front of the instrument. It includes three status LEDs.

Each LED provides information about the status of the MSD. In addition, if power to the MSD is interrupted, all three LEDs will blink until the data system reestablishes contact with the MSD and downloads the proper information to the HP-IB/MS control card.

### **Power status LED**

The power status LED lights when the MSD is connected to a power source and the power switch is on.

### **Analyzer status LED**

The analyzer (ion source, mass filter, and detector) is turned off except when the MSD is acquiring data or tuning. This helps extend the life spans of the filaments and electron multiplier horn. The analyzer status LED lights when the MSD receives the MS ON signal from the data system. The analyzer LED should always be on during data acquisition or tuning.

### **Cal valve status LED**

The cal (calibration) valve status LED lights when the data system instructs the calibration valve to open.

### **Power switch**

The power switch is part of the electronics module, and is located on the lower left of the front of the MSD. It is used to switch the MSD and foreline pump on and off.

---

**CAUTION**

---

Do not switch the MSD off unless it has completed the vent program. Incorrect shutdown can seriously damage the MSD.

Status display and power switch

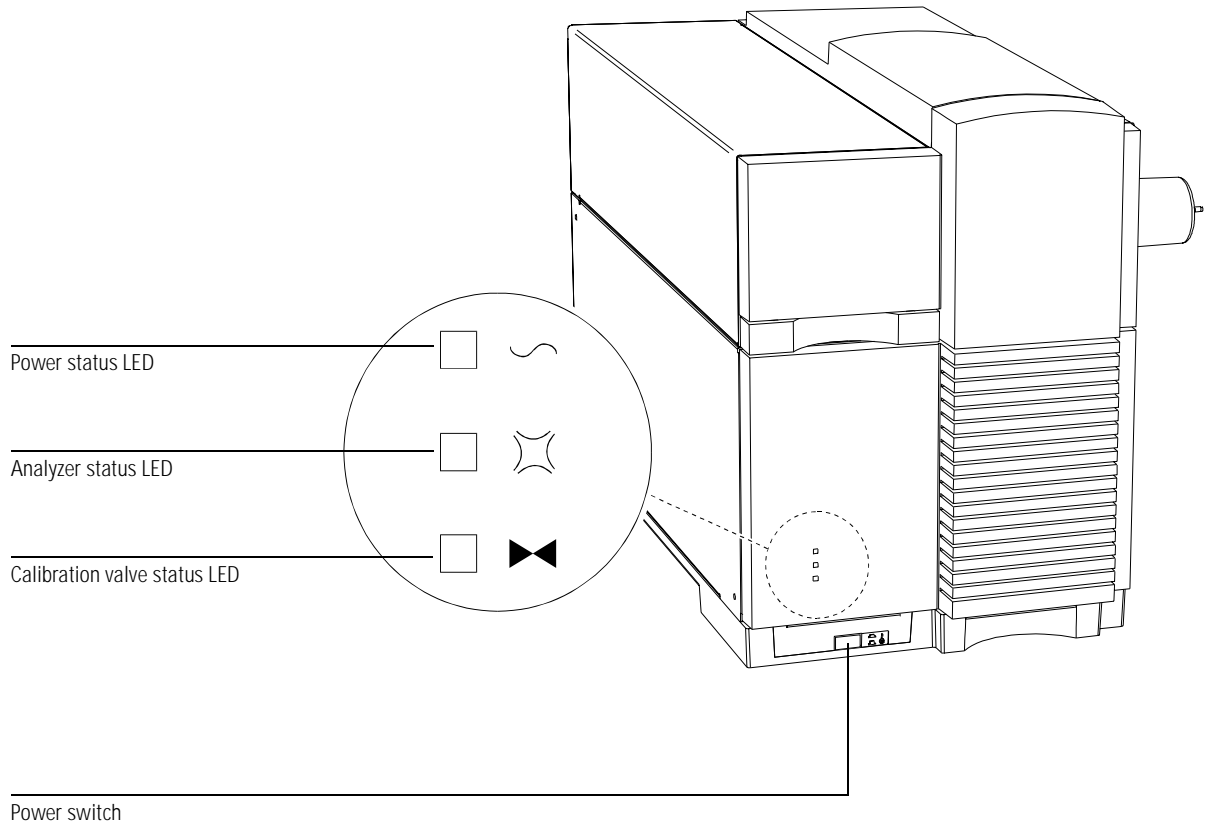

## Turbo pump controller

The turbo pump controller provides power to the turbomolecular pump and regulates pump speed. If the pump fails to reach 80% speed within 10 minutes after beginning pumpdown, or if the speed drops below 50% during operation, the controller shuts off the turbo pump and triggers a fault state.

Electronics, 256  
Vacuum system, 260  
Analyzer, 268  
GC/MSD interface, 274  
Consumables and maintenance supplies, 276

---

## Parts

This chapter lists parts that can be ordered for your MSD

---

# Parts

This chapter lists parts that can be ordered for use in maintaining your HP 5973 MSD. It includes most of the parts or assemblies in the MSDs. This chapter is organized so that related parts are grouped together.

Some of the parts listed are not user-replaceable. They are listed here for the convenience of Hewlett-Packard service representatives.

## ***To order parts***

To order parts for your MSD, address the order or inquiry to your local Hewlett-Packard office. Supply them with the following information:

- Model and serial number of your MSD
- HP part number(s) of the part(s) needed
- Quantity of each part needed

## ***Some parts are available as rebuilt assemblies***

Rebuilt assemblies pass all the same tests and meet all the same specifications as new parts. Rebuilt assemblies can be identified by their part numbers. The first two digits of the last five digits of the part number are 69 or 89 (i.e., XXXXX-69XXX). Rebuilt assemblies are available on an exchange-only basis. When you return the original part to Hewlett-Packard (after you receive the rebuilt assembly) you will receive a credit.

***If you cannot find a part you need***

If a part you need is not listed in this chapter, check the *Hewlett-Packard Analytical Supplies Catalog*. If you still can not find it, contact your Hewlett-Packard service representatives or your local Hewlett-Packard office.

---

## Electronics

The printed circuit boards in the MSD are available only as complete assemblies. Individual electronic components are not available. This section contains the following parts: cables, fuses, printed circuit boards (electronic assemblies).

Table 8

---

### Internal Cables

Description	HP part number
AC board control cable (AC board to main board) <sup>1</sup>	G1099-60422
Chassis ground wire <sup>1</sup>	G1099-60433
Diffusion pump control cable	G1099-60437
Electronics module fan cable <sup>1</sup>	G1099-60560
Fan (high vacuum) cable	G1099-60561
Feedthrough board (inside vacuum manifold)	G1099-60425
HED control cable <sup>1</sup>	G1099-60430
HED power cable <sup>1</sup>	G1099-60431
High vacuum power extender cable (AC board to back panel) <sup>1</sup>	G1099-60436
Low voltage power supply input cable (AC board to LV PS) <sup>1</sup>	G1099-60426
Low voltage power supply output cable (LV PS to main board) <sup>1</sup>	G1099-60427
Mass filter contact cable kit (inside vacuum manifold)	G1099-60130
Side board control (ribbon) cable (main board to side board) <sup>1</sup>	G1099-60410
Signal cable (signal feedthrough on side plate to signal amplifier board) <sup>1</sup>	G1099-60416
Source power cable (main board to side board) <sup>1</sup>	G1099-60428
Turbo pump control cable (back panel to turbo controller)	G1099-60438
Turbo pump power cable (back panel to turbo controller)	G1099-60435

<sup>1</sup> Not a user-replaceable part. Refer service to your Hewlett-Packard service representative.

Table 9

---

**External cables**

---

<b>Description</b>	<b>HP part number</b>
Remote start cable	G1530-60930
HP-IB cable, 1-meter	8120-4654
Power cord, Australia, China	8120-1369
Power cord, Denmark	8120-2956
Power cord, Europe	8120-1689
Power cord, India / South Africa	8120-4211
Power cord, Japan (200 V)	G2025-60189
Power cord, Switzerland	8120-2104
Power cord, UK, Hong Kong, Singapore	8120-1351
Power cord, US	8120-1378
Triode gauge cable (triode gauge tube to gauge controller)	8120-6573

---

Table 10

---

**Fuses and power switch**

---

<b>Description</b>	<b>HP part number</b>
Fuse 4A, 250V, fast-acting, low breaking (ac board and main board) <sup>1</sup>	2110-0875
Fuse, 8A, 250V, time-lag, high breaking capacity (primary fuses)	2110-0969
Power button <sup>1</sup>	5041-1203
Power switch extender rod <sup>1</sup>	G1099-40007
Switch adapter <sup>1</sup>	G1099-20026

---

1 Not a user-replaceable part. Refer service to your Hewlett-Packard service representative.

Table 11

**Printed circuit boards<sup>1</sup>**

Description	HP part number
Electronics module, 120V	G1099-69222
Electronics module, 240V	G1099-69223
ac board	G1099-69003
fan for electronics module <sup>1</sup>	3160-1038
high voltage (HED) power supply	G1099-80017
HP-IB/MS control card	05990-69412
30-pin SIMM (2 required)	1818-4271
72-pin SIMM (1 required)	1818-5709
low voltage (ac-dc) power supply	0950-3067
main board	G1099-69010
signal amplifier board	G1099-69001
toroid transformer <sup>2</sup>	G1099-60229
Side board	G1099-69015
Turbo pump controller	G1099-89002

- 1 None of the parts in this table are user-replaceable parts. Refer service to your Hewlett-Packard service representative.
- 2 The toroid transformer is plugged into to one of two sockets on the AC board, depending on input line voltage.

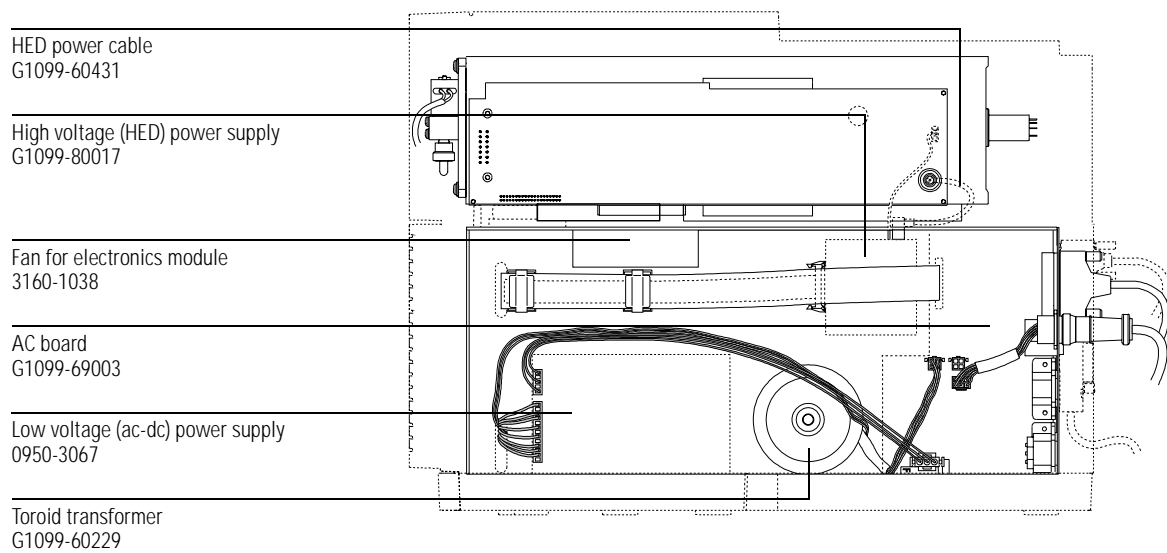
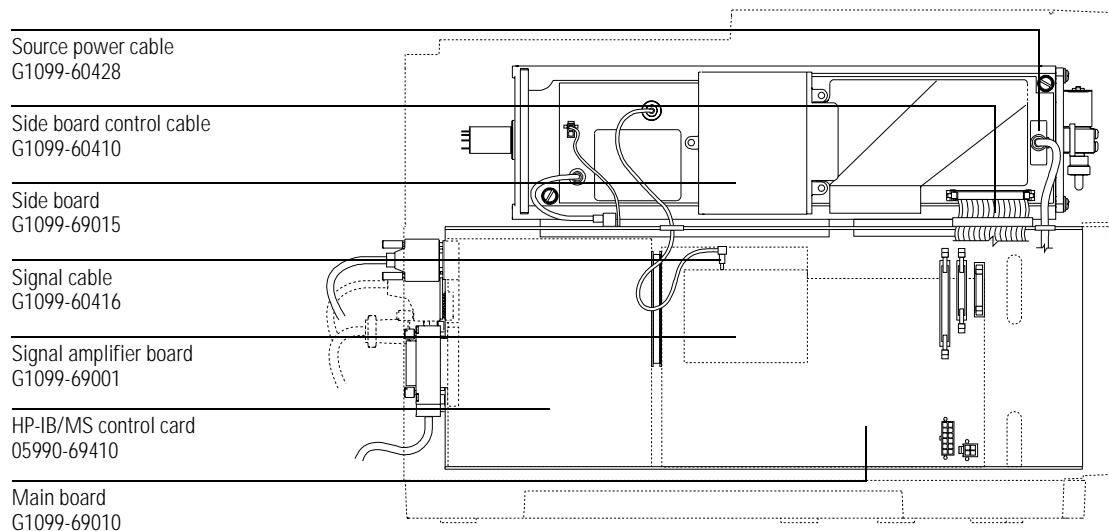

---

## Vacuum system

This section lists replacement parts available for the vacuum system. It includes: clamps, O-rings and seals, foreline pump and related components, diffusion pump vacuum system components, and turbomolecular pump vacuum system components.

Table 12

---

### O-rings and seals

---

Description	HP part number
Calibration valve O-ring (1/4-inch)	0905-1217
Diffusion pump baffle adapter O-ring	0905-1443
End plate O-ring (for front and rear end plates)	0905-1441
GC/MSD interface O-ring	0905-1405
HED feedthrough	G1099-80012
HED feedthrough O-ring	0905-0490
KF10/16 seal (foreline pump inlet, oil trap, and diffusion pump outlet)	0905-1463
KF25 O-ring assembly (turbo pump outlet)	0100-1551
KF50 seal (diffusion pump inlet)	0100-1884
Side plate O-ring	0905-1442
Triode gauge tube O-ring	0905-1070
Turbo pump seal <sup>1</sup>	0100-1879
Vent valve O-ring (1/4-inch)	0905-1217

---

1 The turbo pump and its seal are not user-replaceable parts. Refer service to your Hewlett-Packard service representative.

Face seal

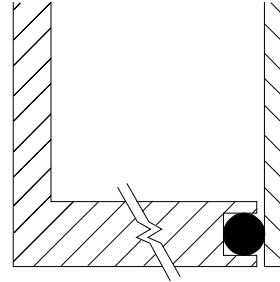
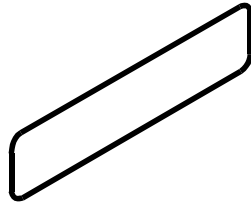

KF seal with internal centering ring

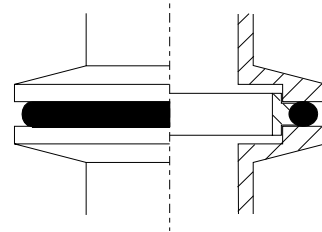

KF seal with external centering ring

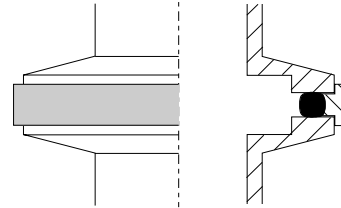
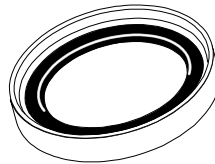

Compression seal

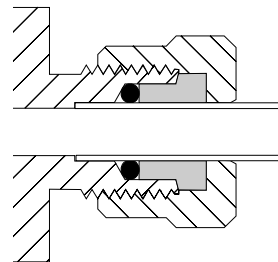

Table 13

---

**Foreline pump and related parts**

---

<b>Description</b>	<b>HP part number</b>
Foreline hose assembly (hose and internal spring)	05971-60119
Foreline pump	
120V	G1099-89023
230V	G1099-89024
Foreline pump inlet seal (KF10/16)	0905-1463
Hose clamp	1400-1234
KF10/16 clamp (foreline inlet and oil trap)	0100-1397
KF16 hose adapter	G1099-20531
KF25 clamp (turbo pump end of foreline hose – not shown)	0100-0549
KF25 hose adapter (turbo pump end of foreline hose – not shown)	G1099-20532
Oil trap (not shown)	3150-0761
Oil trap adapter (not shown)	0100-1883
Oil trap seal (KF10/16)	0905-1463

Foreline hose  
05971-60119

Hose clamp  
1400-1234

KF16 hose adapter  
G1099-20531

KF 10/16 clamp  
0100-1397

KF10/16 seal  
0905-1463

Foreline pump  
120 V ac G1099-89023

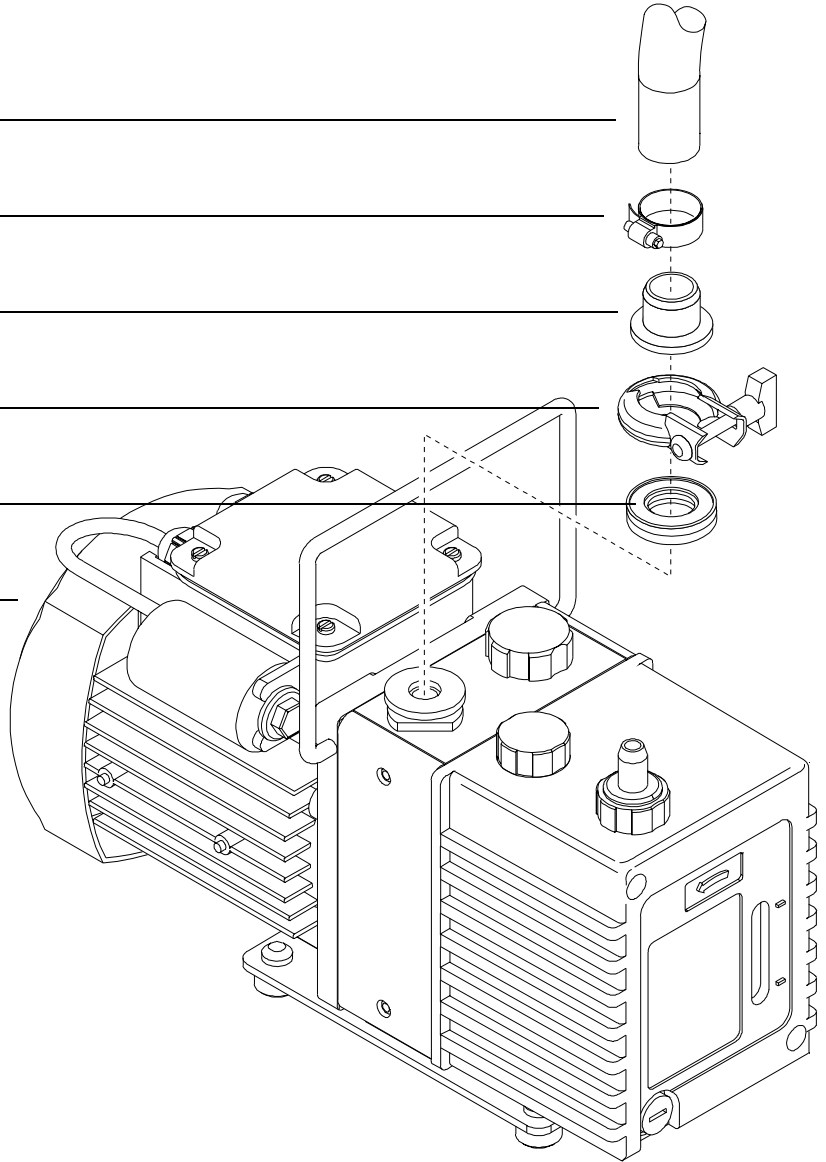

Table 14

---

**Diffusion pump MSD vacuum system components**

---

<b>Description</b>	<b>HP part number</b>
Baffle (inside stem of triode gauge tube – not shown)	05972-00015
Calibration valve assembly	G1099-60200
calibration vial	05980-20018
Claw clamps for baffle adapter	0100-1881
Collar for triode gauge tube (not shown)	05972-60210
Diffusion pump	
120V	G1099-80500
220/240V	G1099-80501
Diffusion pump baffle adapter	G1099-20021
Diffusion pump baffle adapter O-ring	0905-1443
Diffusion pump control cable	G1099-60437
End plate	
front	G1099-20552
rear	G1099-20553
Fan (for high vacuum pump)	3160-1037
Foreline gauge assembly	G1099-60545
Foreline gauge seal	0905-1463
KF10/16 clamp (diffusion pump outlet)	0100-1397
KF10/16 seal (diffusion pump outlet)	0905-1463
KF50 clamp	0100-1395
KF50 seal (foreline pump to baffle adapter)	0100-1884
Shield for triode gauge tube port (not shown)	G1099-00003
Side plate (includes feedthroughs and thumbscrews)	G1099-60021
Triode gauge tube	0960-0897
Vacuum manifold	G1099-20549
Vent valve knob	G1099-20554

---

Calibration valve assembly  
(diffusion pump version)  
G1099-60200

Vent valve knob  
G1099-20554

Vacuum manifold  
(diffusion pump version)  
G1099-20549

Side plate  
G1099-60021

Triode gauge tube  
0960-0897

Diffusion pump baffle adapter  
G1099-20021

KF50 clamp  
0100-1395

Diffusion pump

120V G1099-80500

Foreline gauge assembly  
G1099-60545

Fan (diffusion pump position)  
3160-1037

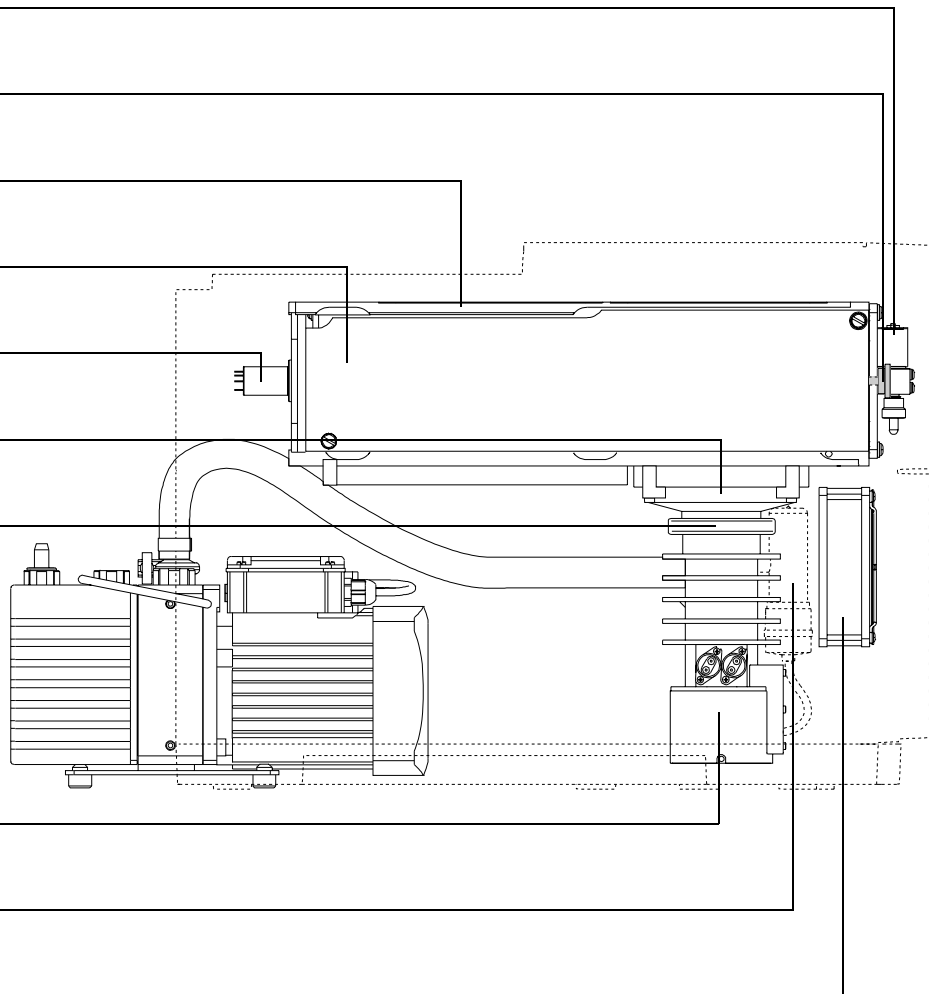

**Vacuum system**

Table 15

**Turbomolecular pump MSD vacuum system components**

Description	HP part number
Baffle (inside stem of triode gauge tube – not shown)	05972-00015
Calibration valve assembly	G1099-60203
calibration vial	05980-20018
Claw clamps for turbo pump	0100-1881
Collar for triode gauge tube	05972-60210
Fan	3160-1037
KF25 clamp (for turbo pump outlet)	0100-0549
KF25 O-ring assembly (for turbo pump outlet)	0100-1551
Manifold end plates	
front	G1099-20552
rear	G1099-20553
Shield for triode gauge tube port	G1099-00003
Side plate (includes thumbscrews)	G1099-60021
Triode gauge tube	0960-0897
Turbomolecular pump <sup>1</sup>	G1946-89001
Turbo pump controller	G1099-89002
Turbo pump seal <sup>1</sup>	0100-1879
Vacuum manifold	G1099-20550
Vent valve knob	G1099-20554

1 The turbo pump and its seal are not user-replaceable parts. Refer service to your Hewlett-Packard service representative.

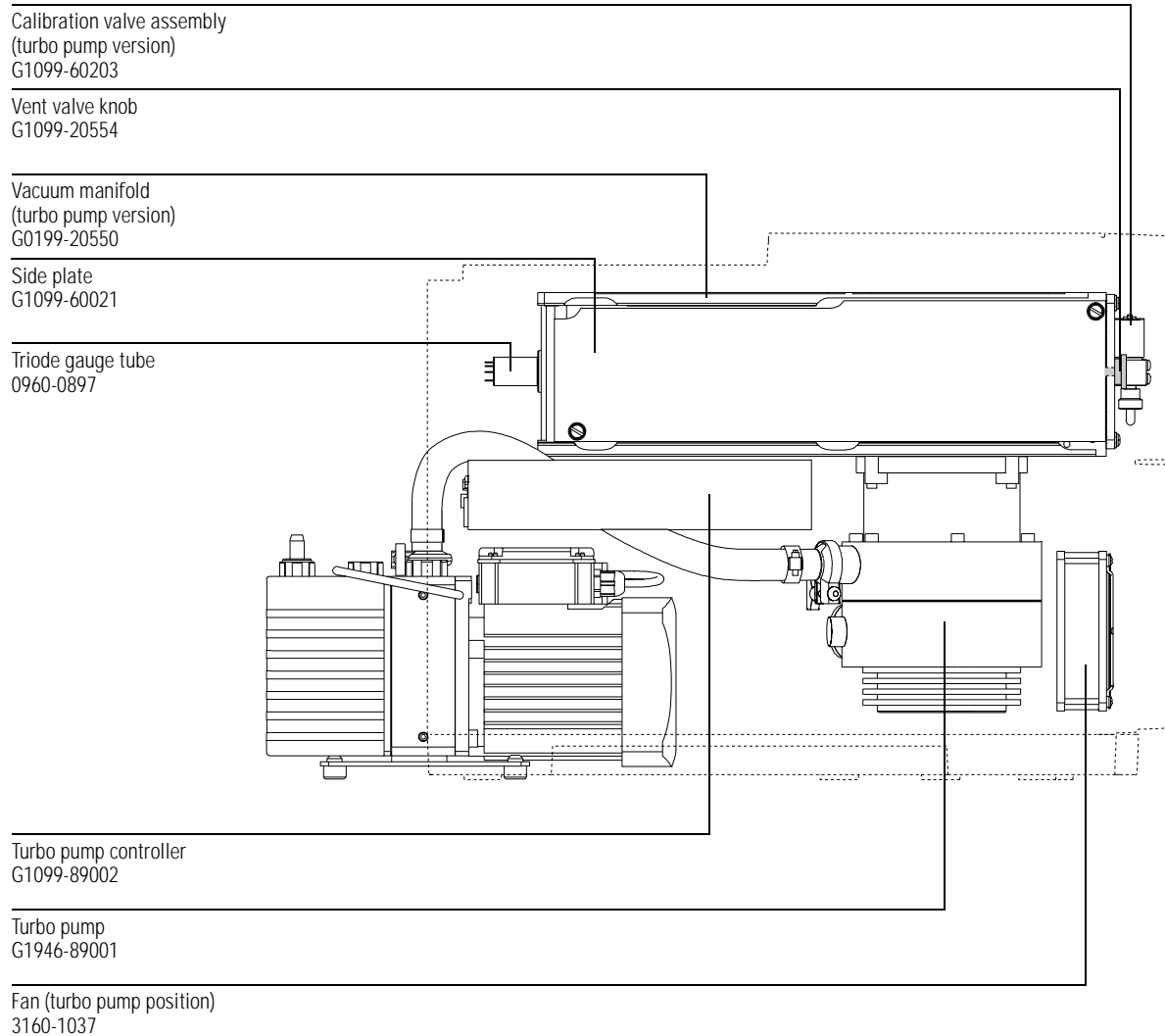

---

## Analyzer

This table lists the replacement parts for the analyzer. Analyzer screws and the individual ion source parts are listed the next tables.

---

**Table 16**

---

**Analyzer parts**

---

<b>Description</b>	<b>HP part number</b>
Analyzer (complete, tested, with side board)	G1099-69228
detector (complete)	G1099-80001
electron multiplier horn	05971-80103
feedthrough board	G1099-60425
HED feedthrough	G1099-80012
O-ring, viton for HED feedthrough	0905-0490
ion source, complete	G1099-69106
magnet assembly	05971-60160
mass filter cable kit	G1099-60130
mass filter contacts (4 required)	G1099-60142
mass filter ceramic support, detector end	G1099-20124
mass filter ceramic support, source end	G1099-20123
mass filter heater assembly	G1099-60172
mass filter radiator	G1099-20121
mounting bracket, detector end	G1099-00002
mounting bracket, source end	G1099-00001
pins for source and detector end mounting brackets	G1099-20137
side plate (includes thumbscrews)	G1099-60021
source radiator	G1099-20122

---

Table 17

**Analyzer screws**

Description	HP part number
Heater/sensor (quadrupole) set screw	0515-1446
Ion source thumbscrew	G1099-20138
Magnet mounting screws	0515-1046
Screw to attach magnet bracket to source radiator	0515-1602
Screws to attach source radiator and detector to quadrupole radiator	0515-1052
Screws for mass filter contact assembly and heater block	0515-0319
Screws for radiator mounting brackets and for side board	0515-0430
Source radiator screws	0515-1052

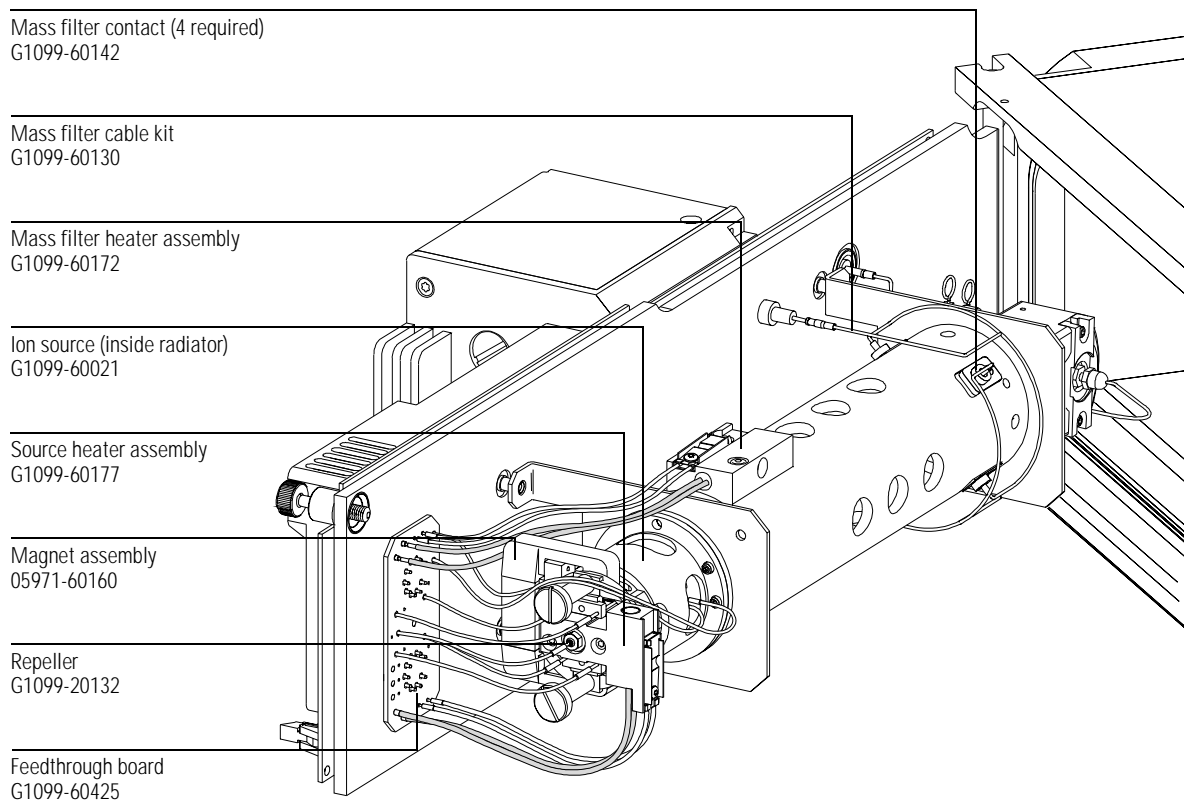

Table 18

---

**Ion source parts**

---

Description	HP part number
Ion source (complete)	G1099-60102
drawout cylinder	G1072-20008
drawout plate	05971-20134
entrance lens	05971-20126
filament	05972-60053
interface socket	G1099-20136
ion focus lens	05971-20143
lens insulator (pair)	05971-20130
repeller assembly (complete)	G1099-60170
screws	
for filaments and holding repeller assembly on source	0515-1046
setscrew for lens stack	0515-1446
source body	G1099-20130

---

Source body  
G1099-20130

Setscrew  
0515-1446

Filament  
05972-60053

GC/MSD interface socket  
G1099-20136

Repeller assembly  
G1099-60170

Screws  
0515-1046

Screws  
0515-1046

Lens insulator (set)  
05971-20130

Entrance lens  
05971-20126

Ion focus lens  
05971-20143

Drawout cylinder  
G1072-20008

Drawout plate  
05971-20134

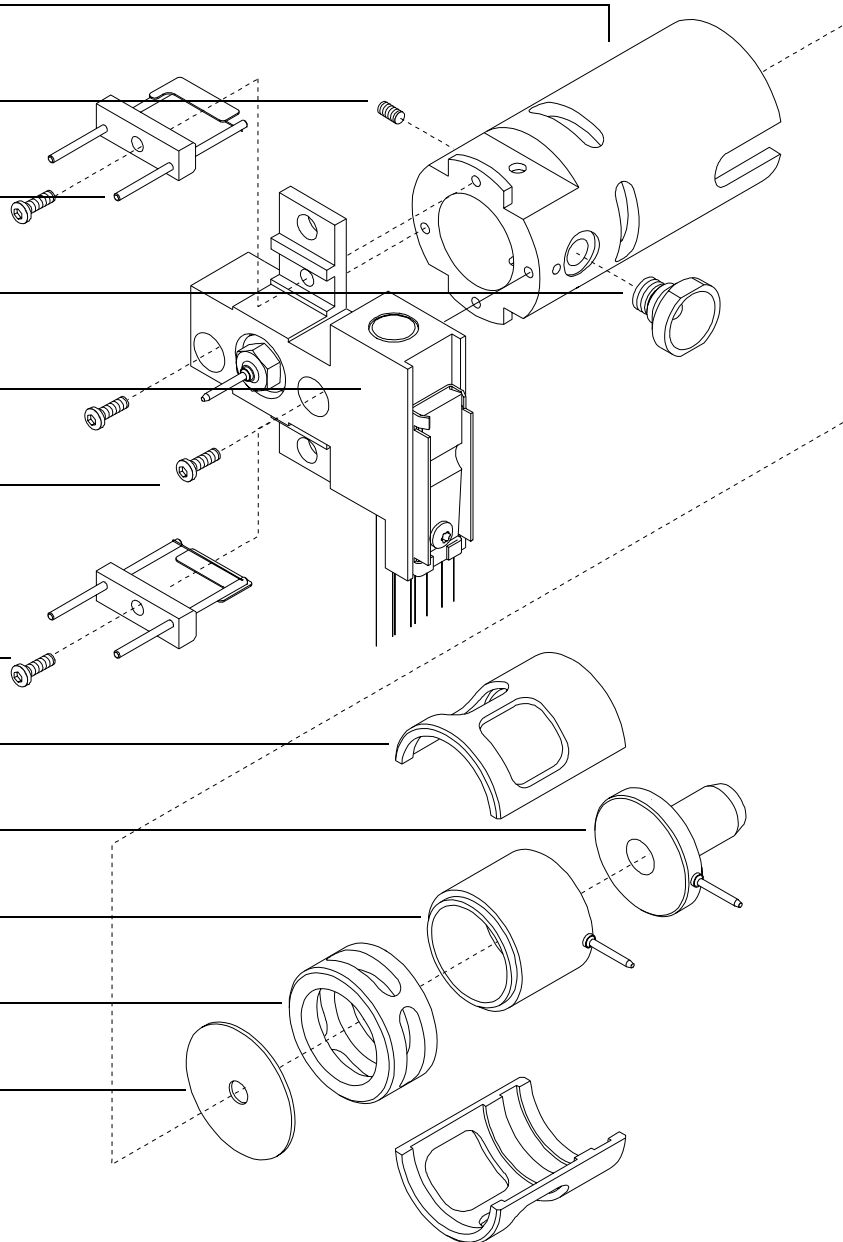

Table 19

---

**Repeller assembly parts**

---

<b>Description</b>	<b>HP part number</b>
Repeller assembly	G1099-60170
insulator (2 required)	G1099-20133
nut, 5.5-mm	0535-0071
repeller	G1099-20132
setscrew	0515-1446
source heater assembly (includes heater, sensor, and heater block)	G1099-60177
washer	3050-0891

Repeller  
G1099-20132

Insulator  
G1099-20133

Setscrew  
0515-1446

Insulator  
G1099-20133

Washer  
3050-0891

Nut, 5.5-mm  
0535-0071

Source heater assembly  
G1099-60177

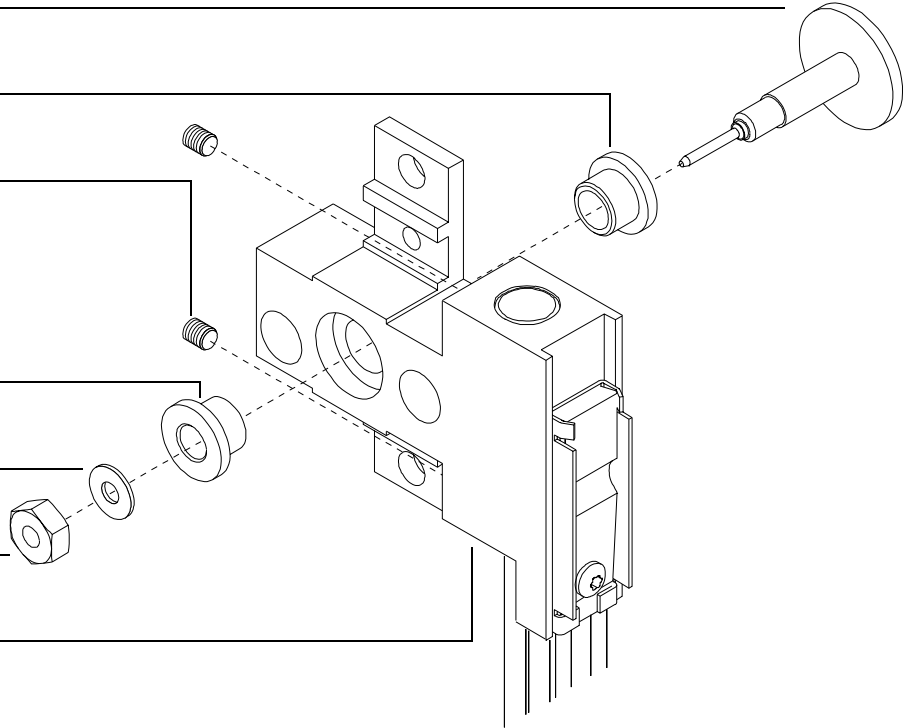

---

## GC/MSD interface

This table lists the replacement parts related to the GC/MSD interface.

Table 20

---

### GC/MSD interface

---

Description	HP part number
GC/MSD interface (complete)	G1099-60300
interface column nut (not shown)	05988-20066
heater sleeve	G1099-20210
heater/sensor assembly	G1099-60107
insulation	G1099-20301
setscrew for heater/sensor assembly (not shown)	0515-0236
screws, M4 x 0.7 panhead, for heater sleeve	0515-0383
welded interface assembly	G1099-60301
GC/MSD interface O-ring	0905-1405
Interface cover	G1099-00005
Screws for mounting interface and cover to vacuum manifold	0515-0380

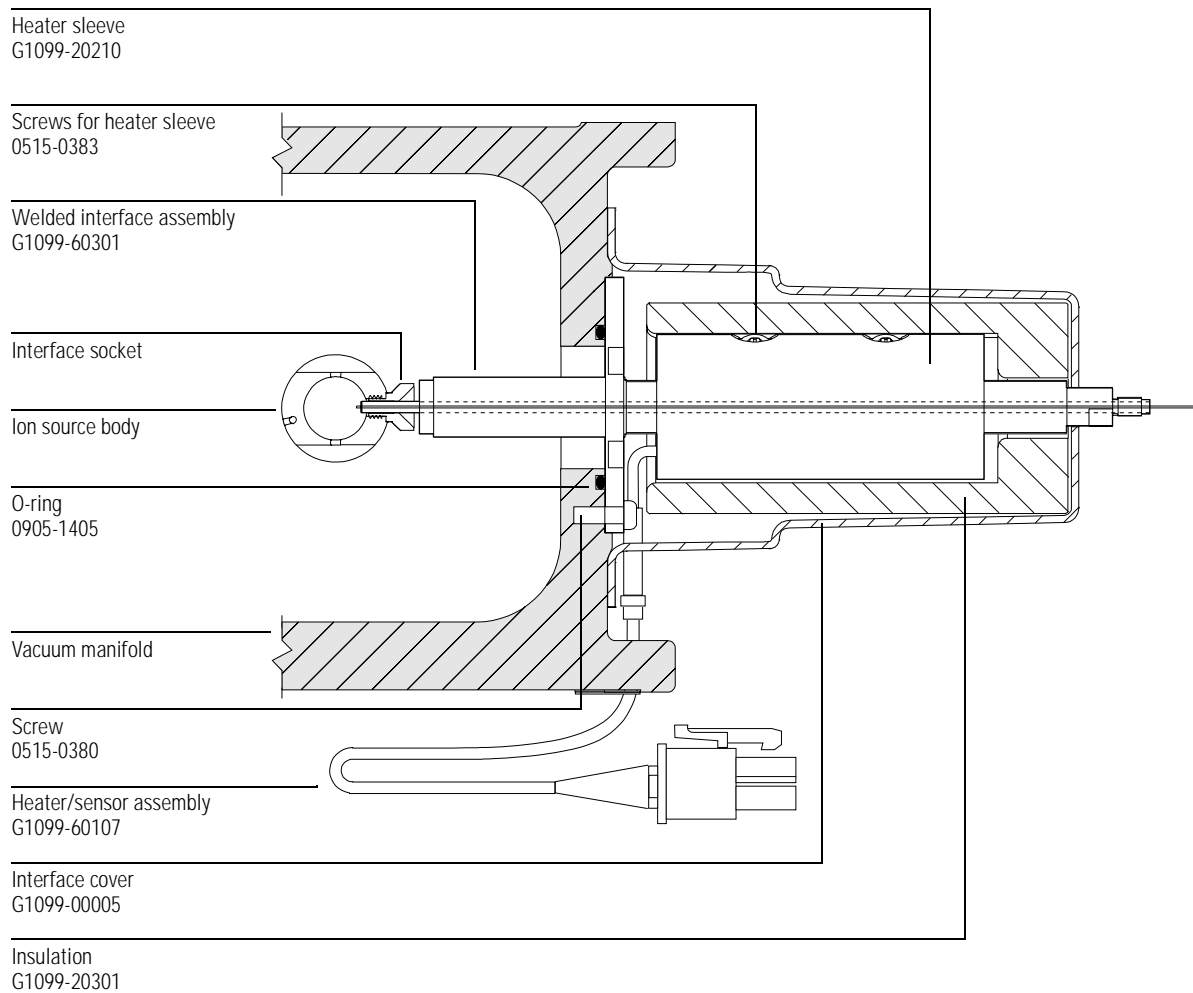

---

## Consumables and maintenance supplies

This section lists parts available for cleaning and maintaining your MSD.

Table 21

---

### Maintenance supplies

---

Description	HP part number
Abrasive paper, 30 $\mu\text{m}$	5061-5896
Alumina powder	8660-0791
Cloths, clean (package of 300)	05980-60051
Cloths, cleaning (package of 300)	9310-4828
Cotton swabs (package of 100)	5080-5400
Diffusion pump fluid (2 required)	6040-0809
Foreline pump oil, Inland 45, 1 liter	6040-0834
Gloves, clean	
large	8650-0030
small	8650-0029
Grease, Apiezon L, high vacuum	6040-0289
Paint, touch-up, Glacier Gray	6010-1497

---

Table 22

<b>Tools</b>	
<b>Description</b>	<b>HP part number</b>
Column installation tool	G1099-20030
Tool kit	G1099-60566
Ball drivers	
1.5-mm	8710-1570
2.0-mm	8710-1804
2.5-mm	8710-1681
Hex nut driver, 5.5-mm	8710-1220
Pliers, long-nose (1.5-inch nose)	8710-1094
Screwdrivers	
flat-blade, large	8730-0002
TORX, T-10	8710-1623
TORX, T-15	8710-1622
TORX, T-20	8710-1615
Shipping kits	
HP 5973 MSD	G1099-60565
HP 6890 Series GC	G1530-60860
Tweezers, non-magnetic	8710-0907
Wrenches, open-end	
1/4-inch x 5/16-inch	8710-0510
10-mm	8710-2353
Wrist strap, anti-static	
small	9300-0969
medium	9300-1257
large	9300-0970

**Consumables and maintenance supplies****Table 23****Ferrules**

<b>Description</b>	<b>HP part number</b>
Blank, graphite-vespel	5181-3308
GC/MSD interface	
0.3-mm id, 85% Vespel 15% graphite, for 0.10-mm id columns	5062-3507
0.4-mm id, 85% Vespel 15% graphite, for 0.20-mm id and 0.25-mm id columns	5062-3508
0.5-mm id, 85% Vespel 15% graphite, for 0.32-mm id columns	5062-3506
0.8-mm id, 85% Vespel 15% graphite, for 0.53-mm id columns	5062-3538
Injection port	
0.27-mm id, 90% Vespel 10% graphite, for 0.10-mm id columns	5062-3518
0.37-mm id, 90% Vespel 10% graphite, for 0.20-mm id columns	5062-3516
0.40-mm id, 90% Vespel 10% graphite, for 0.25-mm id columns	5181-3323
0.47-mm id, 90% Vespel 10% graphite, for 0.32-mm id columns	5062-3514
0.74-mm id, 90% Vespel 10% graphite, for 0.53-mm id columns	5062-3512

Table 24

---

**Miscellaneous parts and samples**

---

<b>Description</b>	<b>HP part number</b>
Diffusion pump fluid (18.5 ml)	6040-0809
Electron multiplier horn	05971-80103
Filament assembly	G1099-60053
Foreline pump oil (1 liter)	6040-0834
Foreline exhaust oil trap	3150-0761
Heater/sensor assemblies	
GC/MSD interface	05972-60106
ion source	G1099-60177
mass filter	G1099-60172
Octafluoronaphthalene (OFN), 1 pg/ul	8500-5441
Perfluorotributylamine (PFTBA), certified (1 gram)	8500-0656
Perfluorotributylamine (PFTBA) sample kit	05971-60571
Vacuum gauges	
foreline gauge assembly	G1099-60545
triode gauge tube	0960-0897



---

## Numerics

219 width, 224

## A

Abrasively cleaning ion source parts, 152  
parts to be cleaned, 150

Abundance

- absolute, 77
- low for  $m/z$  502, 77
- relative, 77

AC board, 241

AC power cord. *See* Power cord

Adding foreline pump fluid, 102

Address switches, HP-IB, 245

Adjusting the RF coils, 179

Air leaks, 89

- as a source of contamination, 90

AMU gain, 223

AMU offset, 224

Analyzer, 215 – 232

- accessing, 54
  - basic components of, 216
  - detector, 227
  - heaters, 230
  - ion source, 218
  - maintaining, 144
  - mass filter, 223
  - part numbers, 268
  - parts that should not be disturbed, 145
  - radiators, 230
  - setting temperatures, 40
- Analyzer status LED, 250
- Analyzer temperatures, 34
- recommended, 230
  - setting, 40

Autotune, 48

- column flow and temperatures for, 48
- relative abundances of  $m/z$  502 produced by different autotunes, 77
- report generated by, 48
- viewing tune history, 48

Auxiliary heated zones, 34

Average linear velocity, calculating, 46

## B

Back panel and connectors, 245

Background, high, 75, 90

Ballast control, on foreline pump, 194

Baseline, chromatographic

- falling, 72
- high, 72
- rising, 72
- wandering, 73

BFB tune, 48

Bleed. *See* Column bleed *or* Septum bleed

## C

Cables

- part numbers for external, 257
- part numbers for internal, 256

Calibration valve, 204

- O-ring, 192
- reinstalling, 132
- removing, 130

Calibration valve status LED, 250

Calibration vial, 204

- refilling and reinstalling, 124
- removing, 122

Capillary columns. *See* Columns

- Carrier gas
  - contaminated, 90
  - flow, 34
  - purity requirement, 18, 32
  - See also* Column flow
- Cautions, *inside front cover*
- Checking
  - diffusion pump fluid, 110
  - foreline pump oil, 102
- Checklist, pre-operation, 32
- Chemical residue, hazardous, 99
- ChemStation, 32
  - controlling temperatures with, 34
  - monitoring temperatures and vacuum, 36
  - setting monitors, 38
  - setting the GC/MSD interface temperature, 42
  - using to pump down the MSD, 58
  - using to tune the MSD, 48
  - using to vent the MSD, 52, 64
- Chromatography, abnormal results, 70
- Cleaning the ion source, 150
- Cleanliness, importance during maintenance, 144
- Closing the vacuum manifold, 56
- Column bleed, 18
  - as a source of contamination, 90
- Column flow, 34
  - calculating average linear velocity, 46
  - effect on vacuum manifold pressure, 45
  - for optimum sensitivity, 35
  - maximum for diffusion pump MSD, 16
  - maximum for turbo pump MSD, 16
  - measuring with the MSD, 34, 46
- Column installation tool, 28
- Column nut
  - leaking, 89
  - part numbers, 20, 28
- Columns
  - conditioning, 18, 24
  - installing, 15 – 30
  - installing in a split/splitless inlet, 22
  - installing in the GC/MSD interface, 26, 28
  - table of size, pressure, and flow, 17
  - tips and hints, 18
  - types that can be used with the MSD, 16
  - See also* Column flow
- Compression seals, 192
- Conditioning capillary columns
  - importance of, 18
  - procedure for, 24
- Conditioning ferrules, 18
- Connectors, 245
  - foreline pump cord receptacle, 246
  - high vacuum power (HIVAC POWER), 246
  - high vacuum signal (HIVAC SIGNAL), 246
  - HP-IB (I/O), 245
  - power cord receptacle, 246
  - remote start, 245, 248
- Consumables, part numbers of, 276
- Contamination, 90
  - avoiding after cleaning the ion source, 144
  - table of common contaminants, 91

---

**D**

- Data system
  - control over pumpdown, 33
  - controlling temperatures with, 34
  - using to ensure correct venting, 34
  - See also* ChemStation
- DC polarity, 225
- Detector, 227
  - difficulty with the EM supply, 84
  - electron multiplier horn, 227
  - electron multiplier voltage, 227
  - replacing the horn, 170
  - steadily increasing EM voltage, 228
- Detector focus lens, 227
- DFTPP tune, 48
- Diffusion pump, 198
  - automatic control of, 198, 199
  - effect of low fluid level in, 79
  - error messages related to, 85
  - part numbers, 264
  - reinstalling, 118
  - removing, 114
  - thermal switches, 199
  - See also* Diffusion pump fluid
- Diffusion pump fluid, 198
  - as a source of contamination, 90
  - checking, 110
  - replacing, 116
- Disassembling the ion source, 148
- Drawout plate and cylinder, 222
- Drying cleaned ion source parts, 144

**E**

- Electron multiplier (EM), 227
  - See also* Detector
- Electronics, 233 – 252
  - ac board, 241
  - ac-dc board. *See* low voltage power supply
  - danger to from electrostatic discharge, 100, 177
  - high voltage (HED) power supply, 243
  - HP-IB/MS control card, 240
  - locations of major components, 235
  - low voltage power supply, 243
  - main board, 238
  - maintaining, 177
  - part numbers, 256
  - power supplies, 243
  - signal amplifier board, 239
  - status display, 250
  - toroid transformer, 244
  - turbo pump controller, 252
- Electrostatic discharge
  - danger to the electronics from, 100, 177
  - precautions to take against, 145, 177
- EM
  - See also* Detector
  - See* Electron multiplier
- EM voltage, 228
- Emission current, 220
  - if there is none, 88
- End plate O-rings, 192
- Entrance lens, 222

## Error messages

- difficulty in mass filter electronics, 84
- difficulty with the EM supply, 84
- difficulty with the fan, 85
- difficulty with the HED supply, 85
- difficulty with the high vacuum pump, 85
- foreline pressure has exceeded 300 mTorr, 86
- internal MS communication fault, 86
- latched, 84
- lens supply fault, 86
- log amplifier ADC error, 86
- no peaks found, 86
- temperature control disabled, 87
- temperature control fault, 87
- the high vacuum pump is not ready, 87
- the system is in standby, 87
- the system is in vent state, 88
- there is no emission current, 88
- there is not enough signal to begin tune, 88
- translating error numbers into messages, 84

ESD. *See* Electrostatic discharge

## Exhaust

- oil trap for foreline pump, 108, 194
- venting the foreline pump, 32

## F

Face seals, 192

Fan, for high vacuum pump, 199, 202

- cleaning, 118
- incorrect operation of, 69, 85
- replacing, 134

## Ferrules

- conditioning, 18
- part numbers, 278

## Filaments, 219

- care, 221
- electron energy, 219
- emission current, 220
- parameters affecting, 219
- reinstalling, 160
- removing, 158
- selection, 219

Flow rate. *See* Column flow

Foreline gauge, 196

- reinstalling, 128
- removing, 126

*See also* Foreline pressure

## Foreline pressure

- exceeding 300 mTorr, 86
- monitoring, 33, 36, 38
- too high, 79
- too low, 80
- typical, 36

## Foreline pump, 194

- ballast control, 194
- effect of low oil level, 79
- incorrect operation, 68
- oil trap, replacing, 108
- part numbers, 262
- power cord receptacle, 246
- venting the exhaust, 32, 99, 194
- vibration, 194

*See also* Foreline pump oil

- 
- Foreline pump oil
- adding and checking, 102
  - as a source of contamination, 90
  - draining, 104
  - refilling the pump with, 106
- Foreline pump power cord receptacle, 246
- Foreline trap. *See* Oil trap
- Foreline vacuum gauge. *See* Foreline gauge
- Fuses
- on the back panel, 246
  - part numbers, 257
  - replacing the primary fuses, 181
- G**
- Gauge controller, 208
- abnormal or blank display, 44, 80
  - connecting to the triode gauge tube, 60
  - indicated vs. actual pressure, 44, 208
  - monitoring pressure with, 33, 44
  - overpressure shutdown, 45
  - power indicator does not light, 81
  - pressure range, 44
- Gauge tube. *See* Triode gauge tube
- GC
- components responsible for air leaks, 89
  - does not turn on, 68
  - sources of contamination in, 90
- GC columns. *See* Columns
- GC interface. *See* GC/MSD interface
- GC keypad, setting GC/MSD interface temperature from, 49
- GC/MSD interface, 211 – 214
- failure to heat up, 83
  - heated zone controlling, 212
  - heater, 34, 212
  - maintaining, 172
  - part numbers, 274
  - reinstalling a heater and sensor, 175
  - removing the heater and sensor, 173
  - See also* GC/MSD interface temperature sensor (thermocouple), 212
- GC/MSD interface temperature, 34
- range, 212
  - setting from the ChemStation, 42
  - setting from the GC, 49
- Grounded wrist strap, 100
- H**
- Heaters
- GC/MSD interface, reinstalling, 175
  - GC/MSD interface, removing, 173
  - heated zone used to power the GC/MSD interface heater, 34
  - ion source, reinstalling, 164
  - ion source, removing, 162
  - mass filter, reinstalling, 168
  - mass filter, removing, 166
  - setting temperature monitors, 38
  - setting temperatures, 40
  - viewing temperature and vacuum status, 36
- HED, 227
- difficulty with the HED power supply, 85
  - See also* Detector
- HED feedthrough
- seal, 193
- HED power supply, 243
- High energy dynode. *See* HED
-

- High vacuum pump
  - difficulty with, 85
  - diffusion pump, 198
  - not ready, 87
  - turbomolecular (turbo) pump, 202
- High vacuum. *See* Vacuum manifold pressure
- High voltage feedthrough. *See* HED feedthrough
- History, Autotune, 48
- Horn, electron multiplier, 227
- HP-IB
  - address switches, 245
  - connector, 245
- HP-IB/MS control card, 240
  - interfacing to external devices, 248
  - RAM on, 240
  - remote control processor, 248
- Hydrogen carrier gas
  - danger of ignition by triode gauge tube, 44
  - flow turned off while MSD is vented, 32
  - hazards during pumpdown, 33, 58
- I**
- I/O (HP-IB) connector, 245
- Indicated pressure, 208
- Installing GC columns, 15 – 30
- Interface socket
  - reinstalling, 154
  - removing, 148
- Interface. *See* GC/MSD interface
- Interfacing to external devices, 248
  - start run input, 249
  - system ready signal, 249
- Ion focus, 222
- Ion source, 218
  - body, 218
  - cleaning, 150 – 153
  - disassembling, 148
  - drawout plate and cylinder, 222
  - drying cleaned parts, 153
  - entrance lens, 222
  - filament care, 221
  - filament, reinstalling, 160
  - filament, removing, 158
  - filaments, 219
  - heater, 230
  - heater and sensor, reinstalling, 164
  - heater and sensor, removing, 162
  - ion focus lens, 222
  - magnet, 221
  - part numbers, 270
  - parts that should not be cleaned, 150
  - reassembling, 154
  - reinstalling, 156
  - removing, 146
  - repeller, 221
- Ion source temperature, 34
  - setting, 40
  - setting a monitor for, 38
  - viewing, 36
- K**
- KF seals, 192
  - part numbers, 260

---

**L**

LEDs. *See* Status Display

Line voltage

- hazards of ungrounded outlet, 32
- symptoms of incorrect or missing, 68, 80

Log amplifier. *See* Signal amplifier

Low sensitivity

- at high masses, 78
- general, 74

Low voltage (ac-dc) power supply, 243

Lubricating

- side plate O-ring, 140
- vent valve O-ring, 142

**M**

*m/z*, 223

*m/z* 14 and 16, symptoms of a large air leak, 75

*m/z* 18, 28, 32, and 44, symptoms of an air leak, 75

*m/z* 502, low or decreasing abundance of, 77

Main board, 238

Maintenance, 93 – ??

- analyzer, 144
- avoiding dangerous voltages during, 97
- calibration valve, refilling, 132
- calibration valve, removing, 130
- calibration vial, refilling, 124
- calibration vial, reinstalling, 124
- calibration vial, removing, 122
- dangerous voltages, 97
- dangerously hot parts, 98
- diffusion pump fluid, checking, 110
- diffusion pump fluid, replacing, 116
- diffusion pump, reinstalling, 118
- diffusion pump, removing, 114
- electron multiplier horn, replacing, 170
- electronics, 177
- fan, replacing, 134
- filament, reinstalling, 160
- filament, removing, 158
- foreline gauge, reinstalling, 128

foreline gauge, removing, 126

foreline pump oil, checking and adding, 102

foreline pump oil, draining, 104

foreline pump, refilling, 106

GC/MSD interface, 172

GC/MSD interface heater and sensor, reinstalling, 175

GC/MSD interface heater and sensor, removing, 173

ion source heater and sensor, reinstalling, 164

ion source heater and sensor, removing, 162

ion source, cleaning, 150

ion source, disassembling, 148

ion source, reassembling, 154

ion source, reinstalling, 156

ion source, removing, 146

mass filter (quadrupole), 226

mass filter heater and sensor, reinstalling, 168

mass filter heater and sensor, removing, 166

primary fuses, replacing, 181

reconnecting the MSD to the GC, 120

RF coils, adjusting, 179

safety during, 97 – 100

schedule, 94

separating the MSD from the GC, 112

side plate O-ring, lubricating, 140

supplies for, 96

tools for, 95, 277

triode gauge tube, reinstalling, 138

triode gauge tube, removing, 136

vacuum manifold, closing, 56

vacuum manifold, opening, 54

vacuum system, 101

vent valve O-ring, lubricating, 142

Malfunctions. *See* Symptoms of malfunctions

Manual tune, 48

Mass assignments, incorrect, 76

Mass filter

219 width, 224

amu gain, 223

amu offset, 224

dc polarity, 225

dc voltage, 223

difficulty with the mass filter electronics, 84

heater, 230

heater and sensor, reinstalling, 168

heater and sensor, removing, 166

maintenance, 226

mass (axis) gain, 225

mass (axis) offset, 225

parameters, 223

radiator, 230

RF voltage, 223

Mass filter temperature

monitor, 38

setting, 40

viewing, 36

Mass gain, 225

Mass offset, 225

Mass spectra

high abundances at  $m/z$  18, 28, 32, and 44 or at  
 $m/z$  14 and 16, 75

high background, 75

inconsistent peak widths, 76

incorrect mass assignments, 76

isotopes missing or ratios are incorrect, 75

precursors, 76

Mass-to-charge ratio, 223

Monitoring

foreline pressure, 36

turbo pump speed, 36

vacuum manifold pressure, 44

Monitors, 38

Moving the MSD, 62

MS error numbers, 84

MSD

dangerous voltages in, 97

dangerously hot parts in the, 98

does not turn on, 68

electronics, 233 - ??

hazards from chemical residue, 99

interfacing to external devices, 248

maintaining, 93 - ??

measuring column flow with the, 46

moving or storing, 62

operating, 31 - ??

troubleshooting, 65 - 92

MSD ChemStation. *See* ChemStation

## N

Noise declaration, *inside front cover*

## O

Oil trap, 194

replacing, 108

On/off switch. *See* Power switch

Opening the vacuum manifold, 54

Operating the MSD, 31 - ??

Ordering parts, 254

O-rings and O-ring assemblies, 192

part numbers, 260

Oxygen, effect of on column bleed, 18

---

**P**

Part numbers, *inside front cover*

*See also* Parts

Parts, 253 – ??

analyzer, 268

consumables, 276

diffusion pump vacuum system, 264

electronic, 256

external cables, 257

ferrules, 278

foreline pump, 262

GC/MSD interface, 274

if you cannot find a part you need, 255

ion source, 270

maintenance supplies, 95, 276, 277

miscellaneous, 279

ordering, 254

O-rings and O-ring assemblies, 260

printed circuit boards, 258

rebuilt assemblies, 254

samples, 279

seals, 260

turbomolecular pump vacuum system, 266

vacuum system, 260

Peak widths, inconsistent, 76

Peaks

at  $m/z$  18, 28, 32, and 44 or at  $m/z$  14 and 16, 75

flat tops, 72

fronting, 71

inconsistent widths, 76

missing, 70, 86

precursors, 76

split tops, 72

tailing, 71

PFTBA (perfluorotributylamine), 204

Polarity (dc), of the mass filter, 225

Power cord

ac, 246

foreline pump, 246

receptacle, 246

Power status LED, 250

Power supplies

high voltage (HED), 243

low voltage (ac-dc), 243

Power switch, 250

Pre-operation checklist, 32

Pressure

foreline pressure too high, 79

foreline pressure too low, 80

indicated vs. absolute, 44

monitoring, 33

monitoring foreline, 36

monitoring vacuum manifold, 44

symptoms indicating malfunctions, 79

typical vacuum manifold pressure for various

carrier gas flows, 45, 196, 198

vacuum manifold pressure too high, 79

vacuum manifold pressure too low, 80

Pressure gauge

*See* Foreline gauge

*See* Triode gauge tube

Printed circuit boards, part numbers, 258

Pumpdown

ChemStation control of, 32

procedure, 58

waiting for thermal equilibrium after, 59

## Q

- Quad temperature, 34
  - See also* Mass filter temperature
- Quadrupole. *See* Mass filter
- Quick Tune, 48

## R

- Radiators, 230
- Relative abundance, 77
- Remote start connector, 245, 248
- Repeatability, poor, 74
- Repeller, 221
  - parts for, 272
- Replacing parts. *See* Maintenance

## S

- Safety
  - covers, 97
  - during maintenance, 97 – 100
- Samples, 279
  - part numbers, 279
- Seals
  - vacuum, 192, 260
  - See also* O-rings and O-ring assemblies
- Sensitivity
  - poor, 74
  - poor at high masses, 78

- Septum bleed, as a source of contamination, 90
- Septum, leaking, 89
- Service agreements, *inside back cover*
- Shutdown. *See* Venting
- Side plate
  - lubricating the O-ring, 140
  - O-ring, 192
  - thumbscrews, 190
- Signal amplifier board, 239
- Signal, not enough to begin tune, 88
- Smartcard. *See* HP-IB/MS control card
- Solvent peak
  - effect if analyzer is on, 84, 85
  - effect on triode gauge, 80
- Startup
  - failure of the MSD to, 68
  - See also* Pumpdown
- Static discharge. *See* Electrostatic discharge
- Status display, 250
  - LEDs all are blinking, 69
- Status LEDs. *See* Status display
- Storing the MSD, 62
- Supplies
  - catalog, 255
  - for maintaining the MSD, 96
- Switch, power. *See* Power switch

---

## Symptoms of malfunctions

- baseline is falling, 72
- baseline is high, 72
- baseline is rising, 72
- baseline wanders, 73
- chromatographic symptoms, 70 – 74
- difficulty in mass filter electronics, 84
- difficulty with the EM supply, 84
- difficulty with the fan, 85
- difficulty with the HED supply, 85
- difficulty with the high vacuum pump, 85
- error messages, 84 – 88
- fan is not operating, 69
- foreline pressure has exceeded 300 mTorr, 86
- foreline pressure is too high, 79
- foreline pressure is too low, 80
- foreline pump is not operating, 68
- gauge controller displays 9.9+9 and then goes blank, 80
- GC does not turn on, 68
- GC/MSD interface will not heat up, 83
- general symptoms, 68 – 69
- high abundances at  $m/z$  18, 28, 32, 44 or at  $m/z \approx 14$  and 16, 75
- high background, 75
- high mass sensitivity is poor, 78
- internal MS communication fault, 86
- ion source will not heat up, 82
- isotopes missing or ratios are incorrect, 75
- LEDs are all blinking, 69
- lens supply fault, 86
- log amplifier ADC error, 86
- mass assignments are incorrect, 76
- mass filter (quad) heater will not heat up, 83
- mass spectral symptoms, 75 – 78
- MSD does not turn on, 68
- MSD is on but status LEDs are all blinking, 69
- no peaks, 70, 86
- peak widths are inconsistent, 76
- peaks are fronting, 71
- peaks are tailing, 71
- peaks have flat tops, 72
- peaks have precursors, 76
- peaks have split tops, 72
- poor repeatability, 74
- poor sensitivity, 74
- power indicator on the gauge controller does not light, 81
- pressure symptoms, 79 – 81
- relative abundance of  $m/z$  502 less than 3%, 77
- retention time drifts (all peaks), 73
- status LEDs are all blinking, 69
- temperature control disabled, 87
- temperature control fault, 87
- temperature symptoms, 82 – 83
- the high vacuum pump is not ready, 87
- the system is in standby, 87
- the system is in vent state, 88
- there is no emission current, 88
- there is not enough signal to begin tune, 88
- vacuum manifold pressure is too high, 79
- vacuum manifold pressure is too low, 80
- System ready signal, 249

## T

- Target tune, 48
- Temperature sensors
  - GC/MSD interface, reinstalling, 175
  - GC/MSD interface, removing, 173
  - in the MSD analyzer, 34
  - ion source, reinstalling, 164
  - ion source, removing, 162
  - mass filter, reinstalling, 168
  - mass filter, removing, 166
- Temperatures, controlled through the MSD Chem-Station, 34
- Thermal Aux #2, 212
- Thermal equilibrium, time to reach, 230
- Tipping the MSD, caution against, 63
- Tools, for maintaining the MSD, 95, 277
- Toroid transformer, 244
- Transfer line. *See* GC/MSD interface
- Transformer, toroid, 244
- Trap. *See* Oil trap
- Triode gauge tube, 206
  - baffle in stem, 206
  - connecting a gauge controller to, 60
  - ignition of hydrogen by, 44, 206, 208
  - implosion hazard, 44
  - monitoring high vacuum pressure, 44
  - reinstalling, 138
  - removing, 136
  - shield, 206
  - turning on, 44
- Troubleshooting, 65 – 92
  - See also* Symptoms of malfunctions
- Tune report, 48

## Tuning, 48

- cannot begin, 88
- compound, 204
  - See also* Autotune
  - See also* the online help in the software
- Turbo pump controller, 252
- Turbomolecular (turbo) pump, 202
  - monitoring the speed of, 36, 38
  - part numbers, 266
- Turn on
  - failure of the MSD to, 68
  - See also* Pumpdown

## U

- Ultrasonic cleaning of ion source parts, 152

## V

- Vacuum gauge
  - See* Foreline gauge
  - See* Triode gauge
- Vacuum manifold
  - closing, 56
  - diffusion pump version, 188
  - monitoring pressure in, 44
  - opening, 54
  - turbo pump version, 189
- Vacuum manifold pressure
  - effect of column flow on, 45
  - monitoring, 44
  - too high, 79
  - too low, 80
  - typical, 45, 196, 198, 202

- 
- Vacuum seals, 192
    - part numbers, 260
  - Vacuum system, 183 – ??
    - determining type, 16
    - diffusion pump system overview, 186
    - maintaining, 101
    - maintenance schedule, 94, 101
    - overview, 184
    - part numbers, 260
    - status, monitoring, 36, 38
    - turbo pump system overview, 187
  - Valve
    - calibration, 204
    - vent, 204
  - Vent cycle
    - See* Venting
  - Vent cycle. *See* Venting
  - Vent program
    - See* Venting
  - Vent program. *See* Venting
  - Vent valve, 204
    - lubricating the O-ring, 142
  - Venting
    - ChemStation control of, 32
    - damage to MSD from incorrect, 34
    - if ChemStation is not working, 64
    - normal, 52
  - Vial
    - calibration, 204
    - See also* Calibration vial
  - Voltages, dangerous, 97

## **W**

- Warnings, *inside front cover*
- Warranty claims, *inside back cover*
- Warranty, *inside back cover*
- Wid219 parameter, 224
- Wiring, dangerous voltages on, 97



---

## Warranty

Hewlett-Packard (HP) warrants its Analytical products against defects in materials and workmanship for the warranty period. During the warranty period, HP will, at its option, repair or replace products which prove to be defective. Products that are installed by HP are warranted from the installation date, all others from the date of delivery.

If Buyer schedules or delays installation more than 30 days after delivery, then warranty period starts on 31st day from the date of shipment. For international orders, the grace period is 60 days and the warranty period starts on the 61st day from the date of shipment.

HP software and firmware products which are designated by HP for use with a hardware product, when properly installed on that hardware product, are warranted not to fail to execute their programming instructions due to defects in materials and workmanship. If HP receives notice of such defects during the warranty period, HP shall repair or replace software media and firmware which do not execute their programming instructions due to such defects. HP does not warrant that the operation of the software, firmware or hardware shall be uninterrupted or error free.

Within HP service travel areas, warranty and installation services for products installed by HP and certain other products designated by HP will be performed at Buyer's facility at no charge. For installation and warranty services outside of HP's service travel area, HP will provide a quotation for the applicable additional services.

The foregoing warranty shall not apply to defects resulting from:

1. Improper or inadequate maintenance, adjustment, calibration or operation by Buyer.
2. Buyer-supplied software, hardware, interfacing or consumables.
3. Unauthorized modifications or misuse.
4. Operation outside of the environmental and electrical specifications for the product.
5. Improper site preparation and maintenance.
6. Customer-induced contamination or leaks.

This warranty may be modified in accordance with the laws of your country. Please consult your local HP office for the period of the warranty, for shipping instructions and for the applicable wording of the local warranty.

## Warranty Claims

If physical damage is found, or if operation is not as specified when the instrument is first received, notify the carrier and the nearest Hewlett-Packard office immediately. The HP office will arrange for repair or replacement of the instrument without waiting for settlement of a claim with the carrier. For other than initial inspection warranty claims, contact your local HP office.

## Service Agreements

Several service agreements are available, each designed to meet a specific need. In addition to a preventive maintenance agreement, others cover specific repair/maintenance services for the HP 5973 Mass Selective Detector, and can provide for the extension of warranty beyond the initial warranty period.

Details of these agreements, together with prices applicable to the particular installation, can be obtained from your local Hewlett-Packard office.

## Power Specifications

- 120 V ac 60 Hz or 220/240 V ac 50 Hz, single-phase, nominal
- 850 VA (diffusion pump) or 700 VA (turbomolecular pump)
- Main supply voltage not to exceed  $\pm 10\%$  of the nominal voltage
- IEC Transient Overvoltage Category (Overvoltage Category) II
- IEC pollution Degree 2

## Environmental Specifications

- Indoor use
- Altitude up to 4000 meters
- Operating environment: 15° to 35°C at constant temperature (constant temperature =  $\pm 2^\circ\text{C}$  per hour)
- Operating humidity: 25 to 50% relative humidity  
Non-operating humidity: 10 to 95% relative humidity, non-condensing





Manual Part Number  
G1099-90027



Printed on recycled paper

Copyright © 1998  
Hewlett-Packard  
Printed in USA 11/98